

## SW-48-RI

### Performer Series Roll-In Rack Washer

- Automatic roll-in utensil washer with timed wash, delay and rinse cycle
- 12 racks per hour. 48 pans per rack
- Timers are all adjustable
- Fully automatic operation with power on/off button
- Hinged door design
- Left-side controls with right-handed hinges or right-side controls with left-handed hinges



### STANDARD FEATURES

- Wash tank heat: electric, gas, steam injection or steam coil
- Pressure regulator
- Single point electrical connection
- Low water cut-off
- Automatic fill
- Three position wash selector (Complete cycle times): Light (260 seconds), Medium (380 seconds), Heavy (500 seconds)
- Emergency cycle stop button
- Wash pump pressure gauge
- Rinse pressure gauge
- Digital temperature controller for wash and rinse
- Pan washer clean-up hose and spray gun
- Secondary system
- Detergent connection provision
- Pit or floor model
- Pressure regulator to maintain 20 psi rinse flow
- SureFire® Start-Up & Check-Out Service

### OPTIONS

- Stainless steel steam coil tank heat
- Steam booster
- Electric booster
- Security package
- Totally enclosed motor
- Recommended option: power vent fan

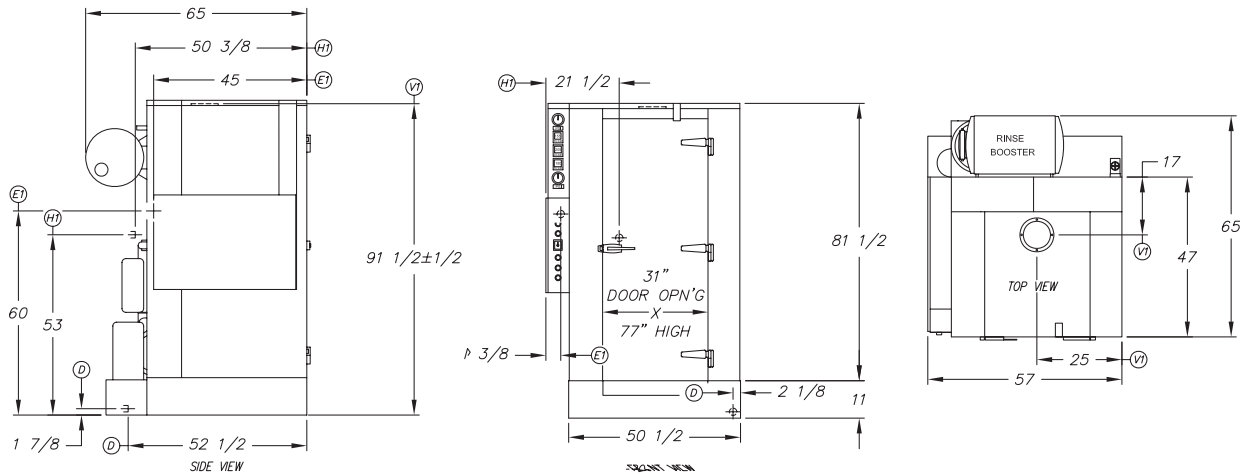

**Note:** For all rough in connections see installation and layout detail drawing.

## SPECIFICATIONS

Capacity Per Hour	12 racks/576 sheet pans			
Tank Capacity	65 gallons			
Motor Size	10 hp + 5 hp series (wash)			
Electric Usage	Electric wash heat (1) 9kW + (1) 4.5 element			
	Rinse booster (2) 9 Kw element			
Gas Consumption	66,000 BTUH 65 CFH nat. gas 7" W.C. min. 26 CFH propane 11" W.C. min.			
Steam Consumption at 10-15 psi min.	37 lbs./hour injected (wash tank) 76 lbs./hour coil (wash tank)			
Final Rinse Peak Flow at 20 psi min.	14 gallons/minute			
Final Rinse Consumption at 20 psi min.	168 gallons/hour 14 gallons/cycle			
Exhaust Hood Requirement	8" steam exhaust vent			
Peak Rate Drain Flow	11 gallons/minute			
Shipping Weight	2440 lbs.			
Current Draw Amps	Electric	Gas	Steam Injector	Steam Coil
208/3/60	133.1	95.6	95.6	45.6
230/3/60	122.3	88.4	88.4	43.2
460/3/60	62.1	45.2	45.2	22.6

**CONSTRUCTION-** Hood and tank constructed of 14 gauge series 300 S/S. Hood unit of all welded seamless construction. 12 gauge series 300 S/S frame, S/S legs and feet. All internal castings are non-corrosive bronze.

**DOORS-** Single front opening door. Extra large die formed series 300 S/S doors.

**PUMP-** Centrifugal type "packless" pump with a drain plug. Construction includes ceramic seal and a balanced cast impeller on a precision ground stainless steel shaft, extension or sleeve. All working parts mounted as an assembly and removable as a unit without disturbing the unit piping. One 10 + 5 hp motor, standard vertical C-face frame, totally enclosed, internally cooled with ball-bearing construction.

**CONTROLS-** Electro-mechanical controls, including motor controls and overload protection, transformer, contactors and all dishwasher integral controls.

**SPRAY SYSTEM-** Wash and rinse spray systems made of type 304 stainless steel tubing. The wash assembly arms are pinned into hub assemblies. Upper and lower wash assemblies are removable without the use of tools. Rinse spray assemblies are removable with the use of simple tools.

**WASH-** 2 full width power spinning wash arms Located on opposite sides of the chamber

**FINAL RINSE-** Side mounted stationary final rinse nozzles. The nozzles produce a cone spray reducing water consumption, maximizing heat retention.

**DRAIN-** Drain valve externally controlled. Overflow assembly with skimmer cap is removable with the use of simple tools for drain line inspection. Heater is protected by low water level control.

**EXHAUST-** A 8-inch diameter exhaust vent companion flange is supplied on the top of the unit.

Note: Due to product improvement we reserve the right to change information and specifications without notice.