



ADMIRAL

Technical Manual

Admiral 44 | Admiral 66 | Admiral 44 VG | Admiral 66 VG





Thank you for purchasing this quality Insinger product.

On the space provided below please record the model, serial number and start-up date of this unit:

Model: _____

Serial Number: _____

Start-Up Date: _____

When referring to this equipment please have this information available.

Each piece of equipment at Insinger is carefully tested before shipment for proper operation. If the need for service should arise please contact your local Authorized Insinger Service Company.

A Service Network Listing is provided on our web site, www.insingermachine.com or call Insinger at 800-344-4802 for your local authorized servicer.

For proper activation of the *Insinger Limited Warranty* a SureFire™ Start-Up & Check-Out Service should be completed on your machine. Refer to the Introduction section in this manual for an explanation of Insinger SureFire™ Start-Up & Check-Out Program.

Please read the Insinger Limited Warranty and all installation and operation instructions carefully before attempting to install or operate your new Insinger product.

To register your machine for warranty by phone, fax or the internet or for answers to question concerning installation, operation, or service contact our Technical Services Department:

TABLE OF CONTENTS

Part 1 Technical Information	3-14
• Cut-sheets & Installation Drawings	
• Introduction	
• Warranties	
Part 2 Installation Instructions	15-16
• Installation and Start-Up Procedures	
Part 3 Operating Instructions	17
• Operating Procedures	
Part 4 Cleaning Instructions	18
• Daily and Weekly Procedures	
Part 5 Maintenance & Repair	19-21
• Maintenance & Repair	
Part 6 Electrical Schematics	22-29
• Machine Wiring Diagrams	

TECHNICAL SERVICE CONTACTS

Toll-Free	800-344-4802
Fax	215-624-6966
E-mail	service@insingermachine.com
Web	www.insingermachine.com

ADMIRAL 44 ADVANCED R-L High Temperature Rack Conveyor Electrically Heated Dishwashing Machine

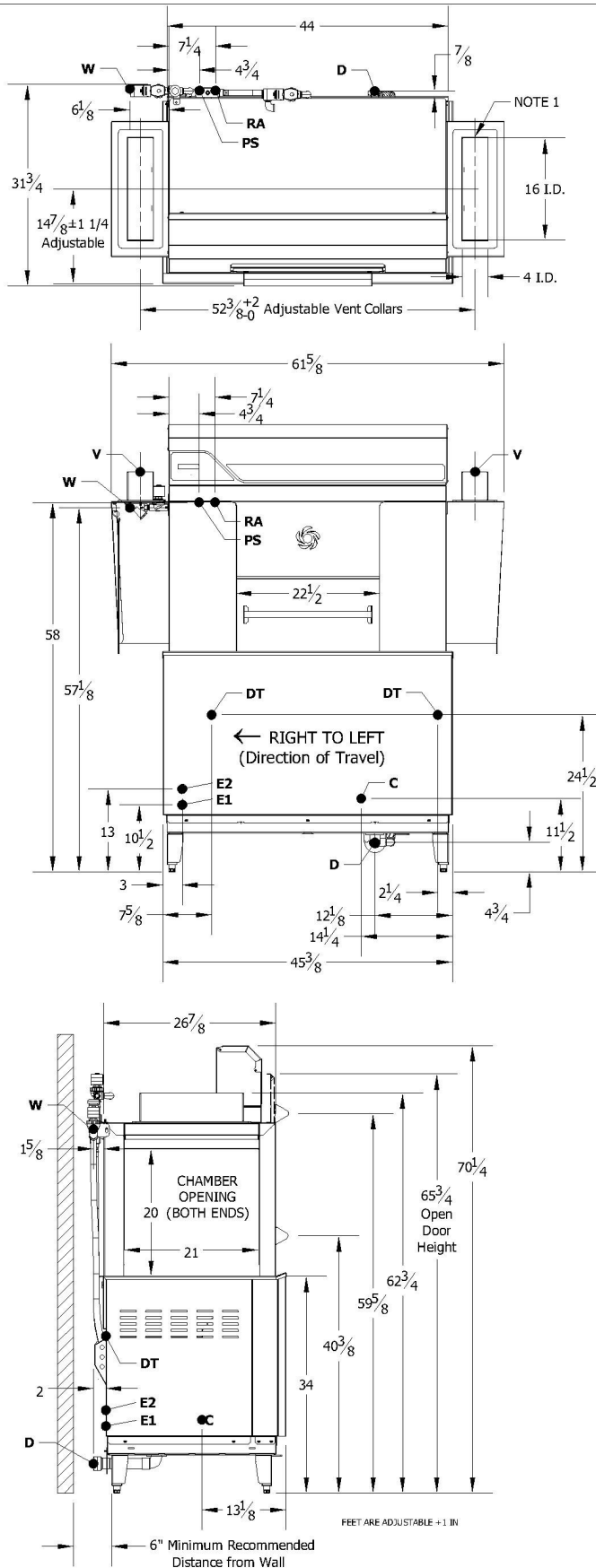

INSTALLATION CONNECTIONS		
	Description	Note
D	DRAIN CONNECTION	1-1/2 FPT
W	HOT WATER INLET (110 F MIN.)	1/2 FPT
E1	MAIN ELECTRICAL (SINGLE & 2-POINT)	1-3/8 HOLE
E2	BOOSTER ELECTRICAL (2 PT ONLY)	1-3/8 HOLE
C	CONDUCTIVITY PROBE LOCATION	7/8 HOLE
DT	DETERGENT INSERSION POINTS	7/8 HOLE
PS	PRESSURE SWITCH CONNECTION	1/4 FPT
RA	RINSE AID CONNECTION	1/4 FPT
V	VENT COLLAR & DAMPERS (OPTIONAL)	4" X 16"

SPECIFICATIONS	
Racks per Hour	234
Dishes per Hour	5225
Meals per Hour	200-400
Wash Tank (gallons)	33.75
Drive Motor HP	1/15
Wash Motor HP	2
Water Consumption @ 20 psi (gal / hr)	147
Gallons per Rack @ 20 psi	0.63
Peak Drain Flow (gpm)	9.0
Tank Heat (kW)	18.0
Booster Heat (kW)	29.4
Venting Load End (CFM min)	350
Venting Unload End (CFM min)	350
Shipping Weight (lbs)	750

SINGLE POINT ELECTRICAL CONNECTION		
Voltage	(E1) Rated Amps	(E1) Min. Circuit Ampacity / Max. Protective Device
208/60/3	138.1	175
240/60/3	120.5	175
480/60/3	60.4	80

DUAL POINT ELECTRICAL CONNECTION				
Voltage	(E1) Rated Amps	(E1) Min. Circuit Ampacity / Max. Protective Device	(E2) Rated Amps	(E2) Min. Circuit Ampacity / Max. Protective Device
208/60/3	56.5	80	81.6	110
240/60/3	49.8	70	70.7	90
480/60/3	25.0	40	35.4	45

- NOTES:
 1. VENTS & ADJUSTABLE DAMPERS FURNISHED ONLY WHEN SPECIFIED.
 2. ALLOW 24" MIN. CLEARANCE BELOW DISH TABLE TO SERVICE ELECTRICAL EQUIPMENT

ALL SPECIFICATIONS ARE SUBJECT TO CHANGE WITHOUT NOTICE

ADMIRAL 44 ADVANCED L-R High Temperature Rack Conveyor Electrically Heated Dishwashing Machine

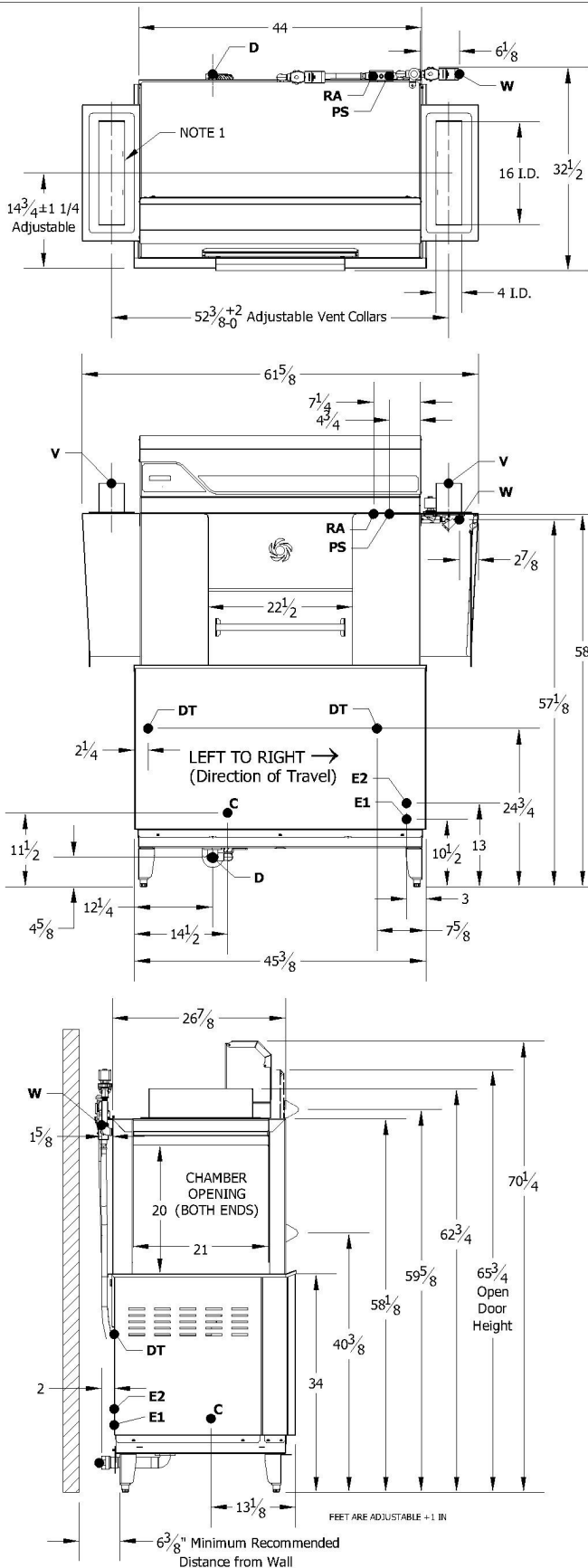

INSTALLATION CONNECTIONS		
	Description	Note
D	DRAIN CONNECTION	1-1/2 FPT
W	HOT WATER INLET (110 F MIN.)	1/2 FPT
E1	MAIN ELECTRICAL (SINGLE & 2-POINT)	1-3/8 HOLE
E2	BOOSTER ELECTRICAL (2 PT ONLY)	1-3/8 HOLE
C	CONDUCTIVITY PROBE LOCATION	7/8 HOLE
DT	DETERGENT INSERSION POINTS	7/8 HOLE
PS	PRESSURE SWITCH CONNECTION	1/4 FPT
RA	RINSE AID CONNECTION	1/4 FPT
V	VENT COLLAR & DAMPERS (OPTIONAL)	4" X 16"

SPECIFICATIONS	
Racks per Hour	234
Dishes per Hour	5225
Meals per Hour	200-400
Wash Tank (gallons)	33.75
Drive Motor HP	1/15
Wash Motor HP	2
Water Consumption @ 20 psi (gal / hr)	147
Gallons per Rack @ 20 psi	0.63
Peak Drain Flow (gpm)	35.0
Tank Heat (kW)	18.0
Booster Heat (kW)	29.4
Venting Load End (CFM min)	350
Venting Unload End (CFM min)	350
Shipping Weight (lbs)	750

SINGLE POINT ELECTRICAL CONNECTION		
Voltage	(E1) Rated Amps	(E1) Min. Circuit Ampacity / Max. Protective Device
208/60/3	138.1	175
240/60/3	120.5	175
480/60/3	60.4	80

DUAL POINT ELECTRICAL CONNECTION				
Voltage	(E1) Rated Amps	(E1) Min. Circuit Ampacity / Max. Protective Device	(E2) Rated Amps	(E2) Min. Circuit Ampacity / Max. Protective Device
208/60/3	56.5	80	81.6	110
240/60/3	49.8	70	70.7	90
480/60/3	25.0	40	35.4	45

- NOTES:
- VENTS & ADJUSTABLE DAMPERS FURNISHED ONLY WHEN SPECIFIED.
 - ALLOW 24" MIN. CLEARANCE BELOW DISH TABLE TO SERVICE ELECTRICAL EQUIPMENT

ALL SPECIFICATIONS ARE SUBJECT TO CHANGE WITHOUT NOTICE

9200-03571 RevAC

ADMIRAL 66 ADVANCED R-L High Temperature Rack Conveyor Electrically Heated Dishwashing Machine

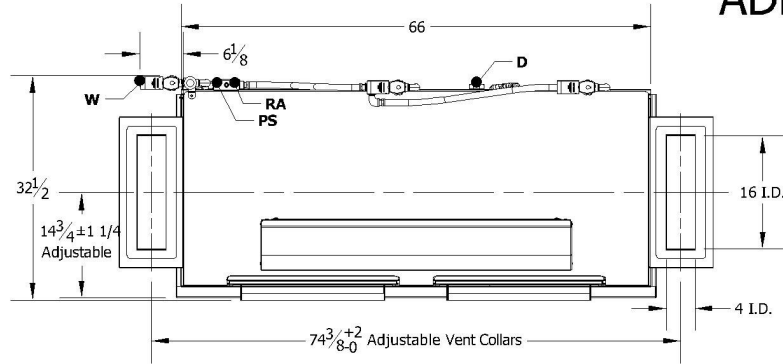

INSTALLATION CONNECTIONS		
	Description	Note
D	DRAIN CONNECTION	1-1/2 FPT
W	HOT WATER INLET (110 F MIN.)	1/2 FPT
E1	MAIN ELECTRICAL (SINGLE & 2-POINT)	1-3/8 HOLE
E2	BOOSTER ELECTRICAL (2 PT ONLY)	1-3/8 HOLE
C	CONDUCTIVITY PROBE LOCATION	7/8 HOLE
DT	DETERGENT INSERTION POINTS	7/8 HOLE
PS	PRESSURE SWITCH CONNECTION	1/4 FPT
RA	RINSE AID CONNECTION	1/4 FPT
V	VENT COLLAR & DAMPERS (OPTIONAL)	4" X 16"

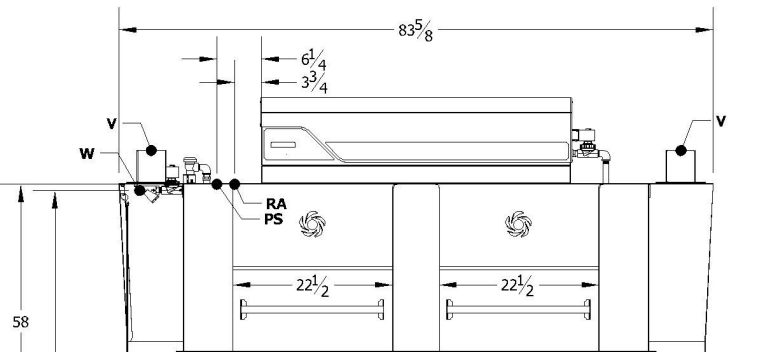

SPECIFICATIONS	
Racks per Hour	234
Dishes per Hour	5225
Meals per Hour	200-400
Wash Tank (gallons)	33.75
Prewash Tank (gallons)	19.5
Drive Motor HP	1/15
Wash Motor HP	2
Prewash Motor HP	1.5
Water Consumption @ 20 psi (gal / hr)	147
Gallons per Rack @ 20 psi	0.63
Peak Drain Flow (gpm)	9.0
Tank Heat (kW)	18.0
Booster Heat (kW)	29.4
Venting Load End (CFM min)	350
Venting Unload End (CFM min)	350
Shipping Weight (lbs)	950

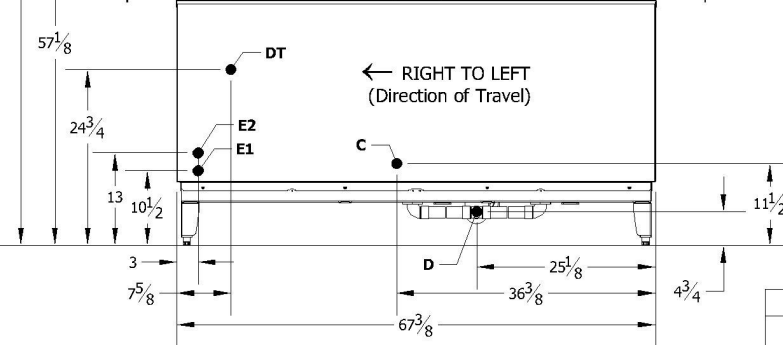

SINGLE POINT ELECTRICAL CONNECTION		
Voltage	(E1) Rated Amps	(E1) Min. Circuit Ampacity / Max. Protective Device
240/60/3	125.2	175
480/60/3	62.5	80

DUAL POINT ELECTRICAL CONNECTION				
Voltage	(E1) Rated Amps	(E1) Min. Circuit Ampacity / Max. Protective Device	(E2) Rated Amps	(E2) Min. Circuit Ampacity / Max. Protective Device
208/60/3	61.2	80	81.6	110
240/60/3	54.5	70	70.7	90
480/60/3	27.1	40	35.4	45

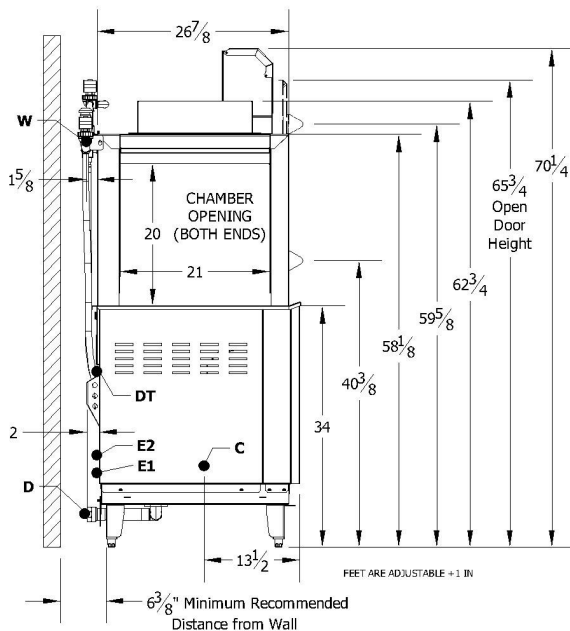

- NOTES:
- VENTS & ADJUSTABLE DAMPERS FURNISHED ONLY WHEN SPECIFIED.
 - ALLOW 24" MIN. CLEARANCE BELOW DISH TABLE TO SERVICE ELECTRICAL EQUIPMENT

ALL SPECIFICATIONS ARE SUBJECT TO CHANGE WITHOUT NOTICE

9200-03574 RevAC

ADMIRAL 66 ADVANCED L-R High Temperature Rack Conveyor Electrically Heated Dishwashing Machine

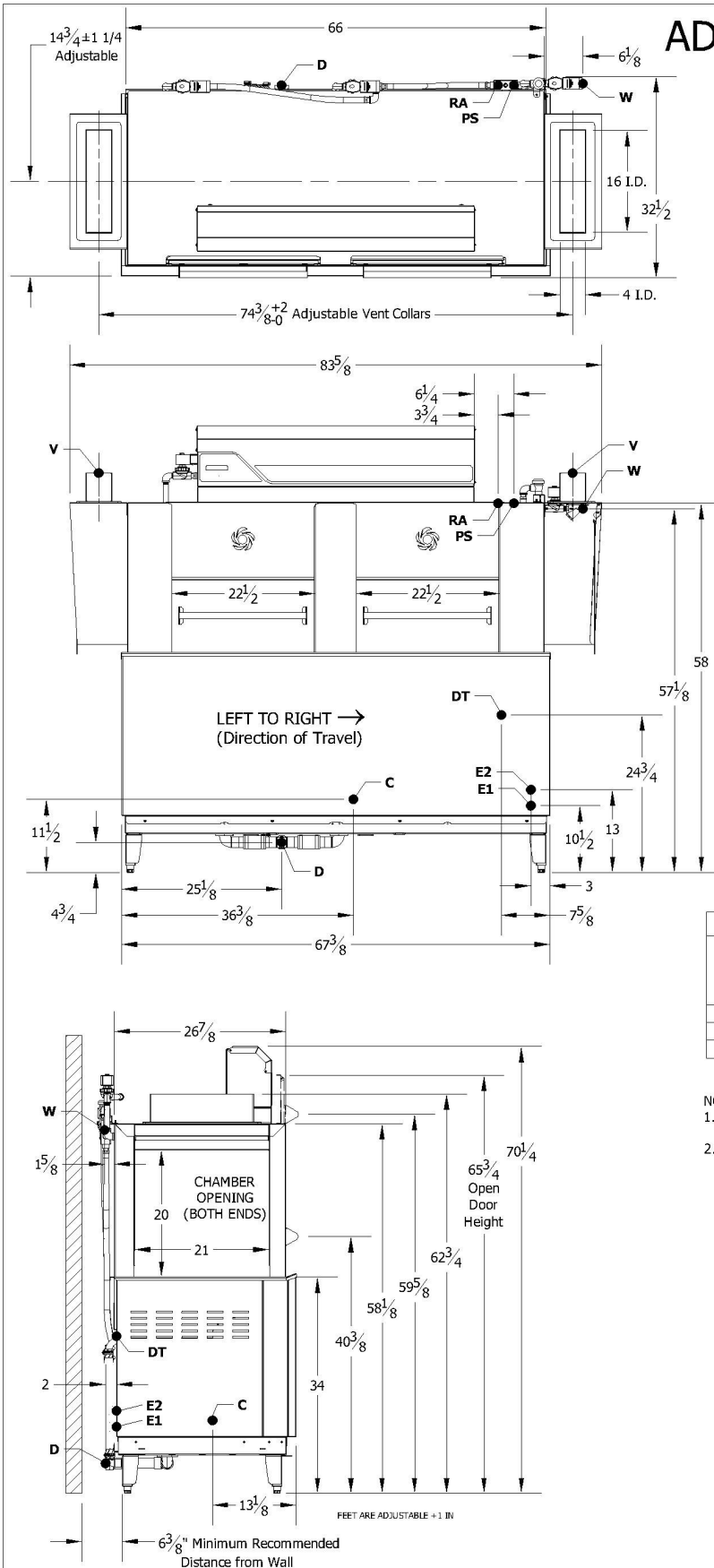

INSTALLATION CONNECTIONS		
	Description	Note
D	DRAIN CONNECTION	1-1/2 FPT
W	HOT WATER INLET (110° F MIN.)	1/2 FPT
E1	MAIN ELECTRICAL (SINGLE & 2-POINT)	1-3/8 HOLE
E2	BOOSTER ELECTRICAL (2 PT ONLY)	1-3/8 HOLE
C	CONDUCTIVITY PROBE LOCATION	7/8 HOLE
DT	DETERGENT INSERION POINTS	7/8 HOLE
PS	PRESSURE SWITCH CONNECTION	1/4 FPT
RA	RINSE AID CONNECTION	1/4 FPT
V	VENT COLLAR & DAMPERS (OPTIONAL)	4" X 16"

SPECIFICATIONS	
Racks per Hour	234
Dishes per Hour	5225
Meals per Hour	200-400
Wash Tank (gallons)	33.75
Prewash Tank (gallons)	19.5
Drive Motor HP	1/15
Wash Motor HP	2
Prewash Motor HP	1.5
Water Consumption @ 20 psi (gal/hr)	147
Gallons per Rack @ 20 psi	0.63
Peak Drain Flow (gpm)	9.0
Tank Heat (kW)	18.0
Booster Heat (kW)	29.4
Venting Load End (CFM min)	350
Venting Unload End (CFM min)	350
Shipping Weight (lbs)	950

SINGLE POINT ELECTRICAL CONNECTION			
Voltage	(E1) Rated Amps	(E1) Min. Circuit Ampacity / Max. Protective Device	
240/60/3	125.2	175	
480/60/3	62.5	80	

DUAL POINT ELECTRICAL CONNECTION				
Voltage	(E1) Rated Amps	(E1) Min. Circuit Ampacity / Max. Protective Device	(E2) Rated Amps	(E2) Min. Circuit Ampacity / Max. Protective Device
208/60/3	61.2	80	81.6	110
240/60/3	54.5	70	70.7	90
480/60/3	27.1	40	35.4	45

- NOTES:
- VENTS & ADJUSTABLE DAMPERS FURNISHED ONLY WHEN SPECIFIED.
 - ALLOW 24" MIN. CLEARANCE BELOW DISH TABLE TO SERVICE ELECTRICAL EQUIPMENT

ALL SPECIFICATIONS ARE SUBJECT TO CHANGE WITHOUT NOTICE

9200-03573 RevAC

ADMIRAL 44 ADVANCED R-L with VAPOR GUARD OPTION High Temperature Rack Conveyor Electrically Heated Dishwashing Machine

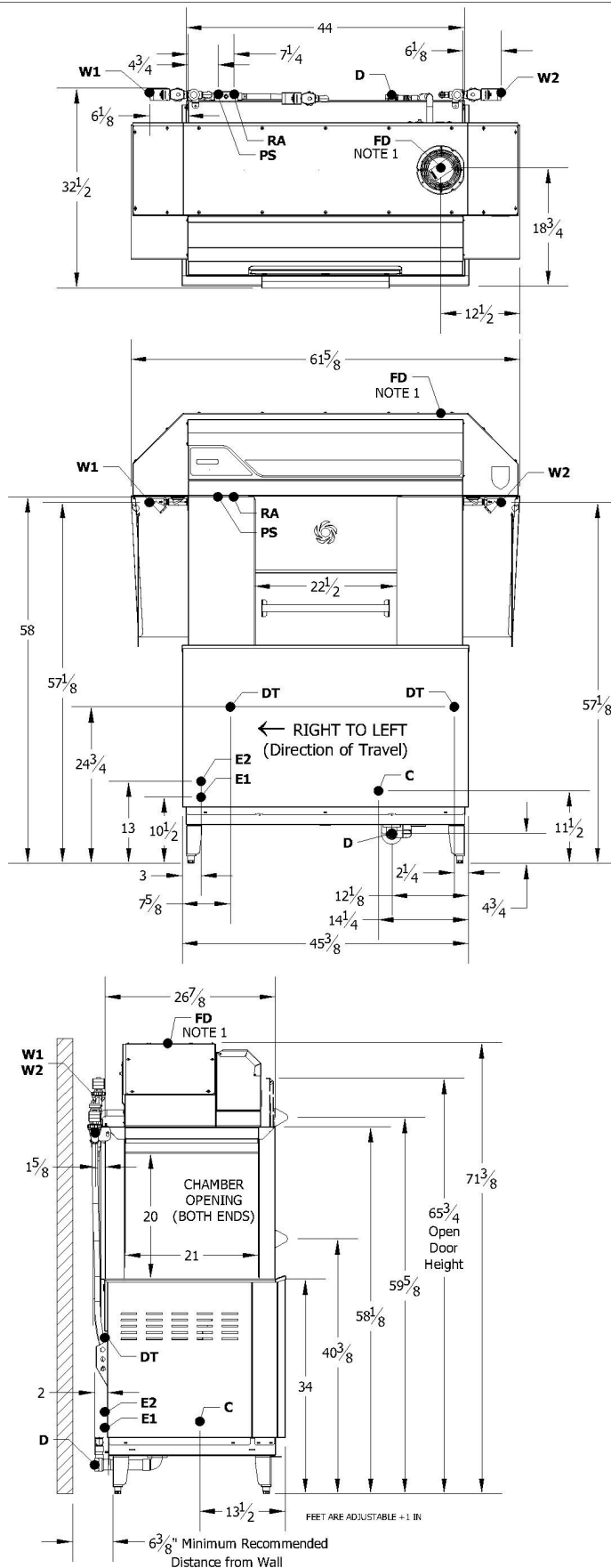

INSTALLATION CONNECTIONS		
	Description	Note
D	DRAIN CONNECTION	1-1/2 FPT
W1	HOT WATER INLET (110° F MIN.)	1/2 FPT
W2	COLD WATER INLET (80° F MAX.)	1/2 FPT
E1	MAIN ELECTRICAL (SINGLE & 2-POINT)	1-3/8 HOLE
E2	BOOSTER ELECTRICAL (2 PT ONLY)	1-3/8 HOLE
C	CONDUCTIVITY PROBE LOCATION	7/8 HOLE
DT	DETERGENT INSERSON POINTS	7/8 HOLE
PS	PRESSURE SWITCH CONNECTION	1/4 FPT
RA	RINSE AID CONNECTION	1/4 FPT
FD	VAPOR GUARD FAN DISCHARGE	(NOTE 1)

SPECIFICATIONS	
Racks per Hour	234
Dishes per Hour	5225
Meals per Hour	200-400
Wash Tank (gallons)	33.75
Drive Motor HP	1/15
Wash Motor HP	2
Water Consumption @ 20 psi (gal / hr)	147
Gallons per Rack @ 20 psi	0.63
Vapor Guard Water Consumption @ 20 psi (gpm)	4.0
Peak Drain Flow (gpm)	9.0
Tank Heat (kW)	18.0
Booster Heat (kW)	29.4
Shipping Weight (lbs)	900

SINGLE POINT ELECTRICAL CONNECTION		
Voltage	(E1) Rated Amps	(E1) Min. Circuit Ampacity / Max. Protective Device
208/60/3	139.1	175
240/60/3	121.5	175
480/60/3	61.4	80

DUAL POINT ELECTRICAL CONNECTION				
Voltage	(E1) Rated Amps	(E1) Min. Circuit Ampacity / Max. Protective Device	(E2) Rated Amps	(E2) Min. Circuit Ampacity / Max. Protective Device
208/60/3	57.5	80	81.6	110
240/60/3	50.8	70	70.7	90
480/60/3	26.0	35	35.4	45

HEAT LOAD	BTU / Hr
LATENT HEAT	6231
SENSIBLE HEAT	10596
TOTAL HEAT	16827

- NOTES:
 1. ALLOW 6" MINIMUM CLEARANCE ABOVE THE VENT FAN DISCHARGE
 2. ALLOW 24" MIN. CLEARANCE BELOW DISH TABLE TO SERVICE ELECTRICAL EQUIPMENT

ALL SPECIFICATIONS ARE SUBJECT TO CHANGE WITHOUT NOTICE

9200-03576 RevAD

ADMIRAL 44 ADVANCED L-R with VAPOR GUARD OPTION High Temperature Rack Conveyor Electrically Heated Dishwashing Machine

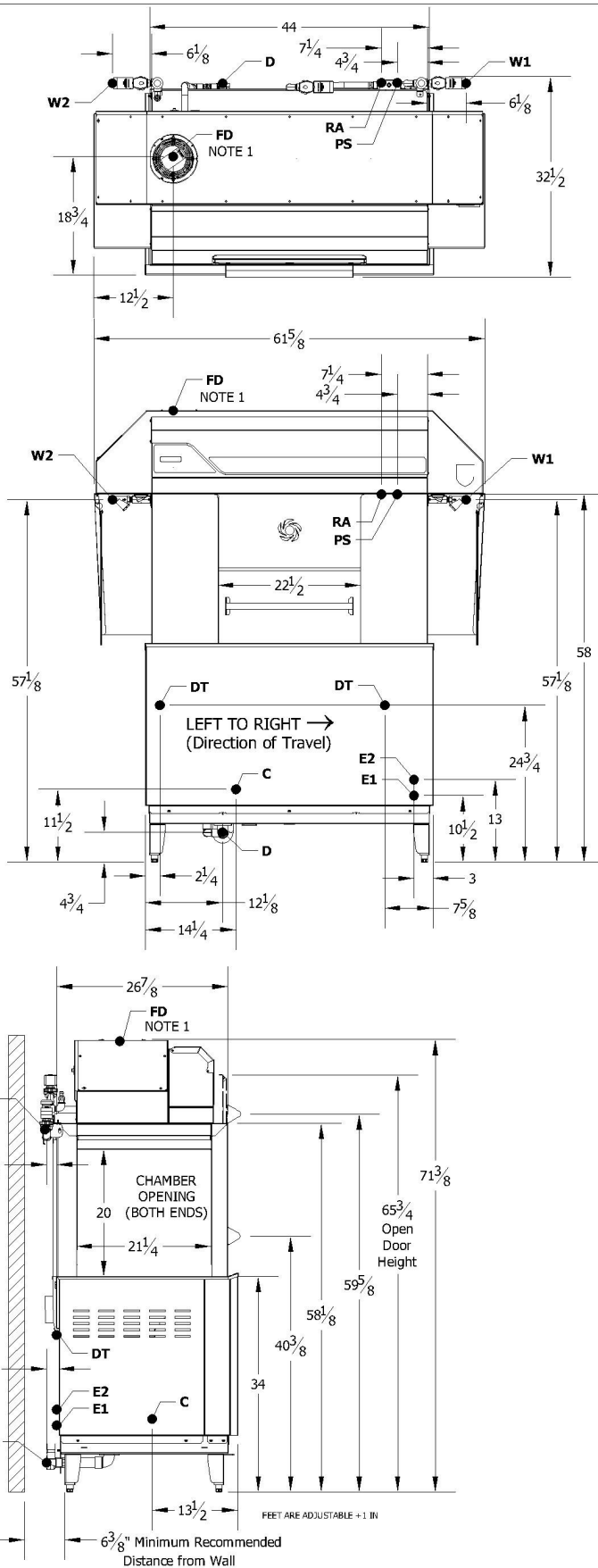

INSTALLATION CONNECTIONS		
	Description	Note
D	DRAIN CONNECTION	1-1/2 FPT
W1	HOT WATER INLET (110° F MIN.)	1/2 FPT
W2	COLD WATER INLET (80° F MAX.)	1/2 FPT
E1	MAIN ELECTRICAL (SINGLE & 2-POINT)	1-3/8 HOLE
E2	BOOSTER ELECTRICAL (2 PT ONLY)	1-3/8 HOLE
C	CONDUCTIVITY PROBE LOCATION	7/8 HOLE
DT	DETERGENT INSERSION POINTS	7/8 HOLE
PS	PRESSURE SWITCH CONNECTION	1/4 FPT
RA	RINSE AID CONNECTION	1/4 FPT
FD	VAPOR GUARD FAN DISCHARGE	(NOTE 1)

SPECIFICATIONS	
Racks per Hour	234
Dishes per Hour	5225
Meals per Hour	200-400
Wash Tank (gallons)	33.75
Drive Motor HP	1/15
Wash Motor HP	2
Water Consumption @ 20 psi (gal / hr)	147
Gallons per Rack @ 20 psi	0.63
Vapor Guard Water Consumption @ 20 psi (gpm)	4.0
Peak Drain Flow (gpm)	9.0
Tank Heat (kW)	18.0
Booster Heat (kW)	29.4
Shipping Weight (lbs)	900

SINGLE POINT ELECTRICAL CONNECTION		
Voltage	(E1) Rated Amps	(E1) Min. Circuit Ampacity / Max. Protective Device
208/60/3	139.1	175
240/60/3	121.5	175
480/60/3	61.4	80

DUAL POINT ELECTRICAL CONNECTION				
Voltage	(E1) Rated Amps	(E1) Min. Circuit Ampacity / Max. Protective Device	(E2) Rated Amps	(E2) Min. Circuit Ampacity / Max. Protective Device
208/60/3	57.5	80	81.6	110
240/60/3	50.8	70	70.7	90
480/60/3	26.0	35	35.4	45

HEAT LOAD	BTU / Hr
LATENT HEAT	6231
SENSIBLE HEAT	10596
TOTAL HEAT	16827

- NOTES:
 1. ALLOW 6" MINIMUM CLEARANCE ABOVE THE VENT FAN DISCHARGE
 2. ALLOW 24" MIN. CLEARANCE BELOW DISH TABLE TO SERVICE ELECTRICAL EQUIPMENT

ALL SPECIFICATIONS ARE SUBJECT TO CHANGE WITHOUT NOTICE

9200-03575 RevAD

ADMIRAL 66 ADVANCED R-L with VAPOR GUARD OPTION High Temperature Rack Conveyor Electrically Heated Dishwashing Machine

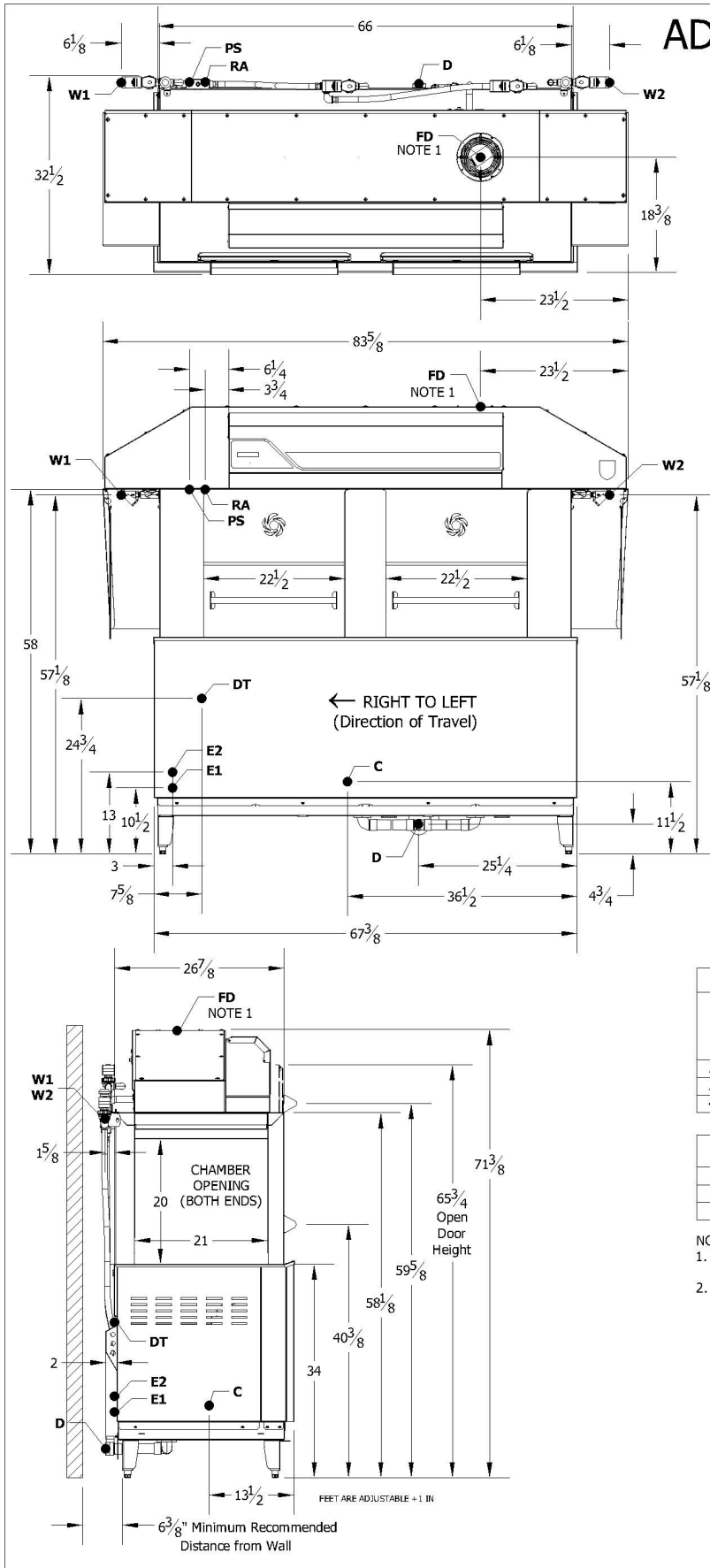

INSTALLATION CONNECTIONS		
	Description	Note
D	DRAIN CONNECTION	1-1/2 FPT
W1	HOT WATER INLET (110° F MIN.)	1/2 FPT
W2	COLD WATER INLET (80° F MAX.)	1/2 FPT
E1	MAIN ELECTRICAL (SINGLE & 2-POINT)	1-3/8 HOLE
E2	BOOSTER ELECTRICAL (2 PT ONLY)	1-3/8 HOLE
C	CONDUCTIVITY PROBE LOCATION	7/8 HOLE
DT	DETERGENT INSERSION POINTS	7/8 HOLE
PS	PRESSURE SWITCH CONNECTION	1/4 FPT
RA	RINSE AID CONNECTION	1/4 FPT
FD	VAPOR GUARD FAN DISCHARGE	(NOTE 1)

SPECIFICATIONS	
Racks per Hour	234
Dishes per Hour	5225
Meals per Hour	200-400
Wash Tank (gallons)	33.75
Prewash Tank (gallons)	19.5
Drive Motor HP	1/15
Wash Motor HP	2
Prewash Motor HP	1.5
Water Consumption @ 20 psi (gal / hr)	147
Gallons per Rack @ 20 psi	0.63
Vapor Guard Water Consumption @ 20 psi (gpm)	4.0
Peak Drain Flow (gpm)	9.0
Tank Heat (kW)	18.0
Booster Heat (kW)	29.4
Shipping Weight (lbs)	1100

SINGLE POINT ELECTRICAL CONNECTION			
Voltage	(E1) Rated Amps	(E1) Min. Circuit Ampacity / Max. Protective Device	
240/60/3	126.5	175	
480/60/3	63.5	80	

DUAL POINT ELECTRICAL CONNECTION				
Voltage	(E1) Rated Amps	(E1) Min. Circuit Ampacity / Max. Protective Device	(E2) Rated Amps	(E2) Min. Circuit Ampacity / Max. Protective Device
208/60/3	62.2	80	81.6	110
240/60/3	55.5	70	70.7	90
480/60/3	28.1	40	35.4	45

HEAT LOAD	BTU / Hr
LATENT HEAT	5921
SENSIBLE HEAT	10311
TOTAL HEAT	16232

- NOTES:
1. ALLOW 6" MINIMUM CLEARANCE ABOVE THE VENT FAN DISCHARGE
 2. ALLOW 24" MIN. CLEARANCE BELOW DISH TABLE TO SERVICE ELECTRICAL EQUIPMENT

ALL SPECIFICATIONS ARE SUBJECT TO CHANGE WITHOUT NOTICE

9200-03578 RevAC

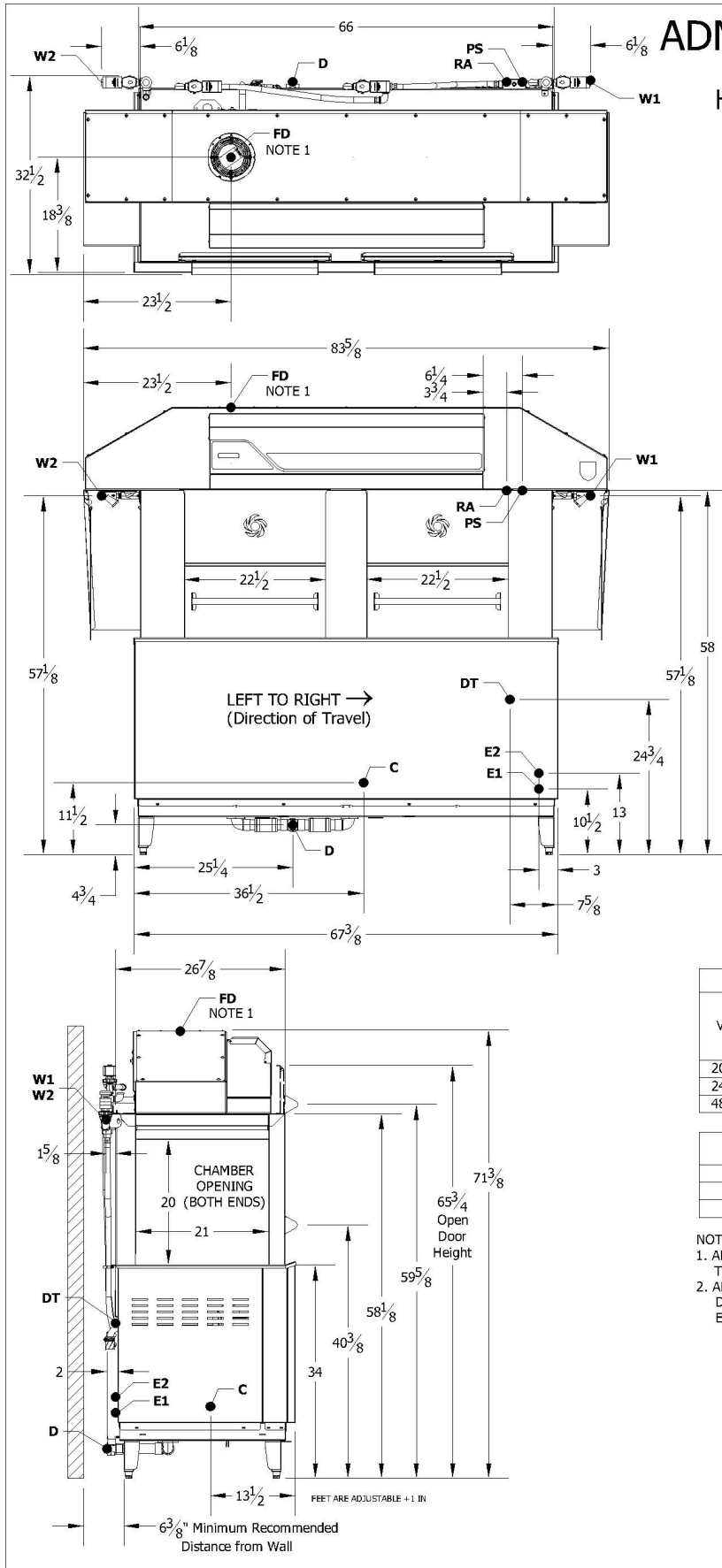

ADMIRAL 66 ADVANCED L-R
with VAPOR GUARD OPTION
High Temperature Rack Conveyor
Electrically Heated
Dishwashing Machine

INSTALLATION CONNECTIONS		
	Description	Note
D	DRAIN CONNECTION	1-1/2 FPT
W1	HOT WATER INLET (110° F MIN.)	1/2 FPT
W2	COLD WATER INLET (80° F MAX.)	1/2 FPT
E1	MAIN ELECTRICAL (SINGLE & 2-POINT)	1-3/8 HOLE
E2	BOOSTER ELECTRICAL (2 PT ONLY)	1-3/8 HOLE
C	CONDUCTIVITY PROBE LOCATION	7/8 HOLE
DT	DETERGENT INSERSION POINTS	7/8 HOLE
PS	PRESSURE SWITCH CONNECTION	1/4 FPT
RA	RINSE AID CONNECTION	1/4 FPT
FD	VAPOR GUARD FAN DISCHARGE	(NOTE 1)

SPECIFICATIONS	
Racks per Hour	234
Dishes per Hour	5225
Meals per Hour	200-400
Wash Tank (gallons)	33.75
Prewash Tank (gallons)	19.5
Drive Motor HP	1/15
Wash Motor HP	2
Prewash Motor HP	1.5
Water Consumption @ 20 psi (gal / hr)	147
Gallons per Rack @ 20 psi	0.63
Vapor Guard Water Consumption @ 20 psi (gpm)	4.0
Peak Drain Flow (gpm)	9.0
Tank Heat (kW)	18.0
Booster Heat (kW)	29.4
Shipping Weight (lbs)	1100

SINGLE POINT ELECTRICAL CONNECTION			
Voltage	(E1) Rated Amps	(E1) Min. Circuit Ampacity / Max. Protective Device	
240/60/3	126.5	175	
480/60/3	63.5	80	

DUAL POINT ELECTRICAL CONNECTION				
Voltage	(E1) Rated Amps	(E1) Min. Circuit Ampacity / Max. Protective Device	(E2) Rated Amps	(E2) Min. Circuit Ampacity / Max. Protective Device
208/60/3	62.2	80	81.6	110
240/60/3	55.5	70	70.7	90
480/60/3	28.1	40	35.4	45

HEAT LOAD		BTU / Hr
LATENT HEAT		5921
SENSIBLE HEAT		10311
TOTAL HEAT		16232

- NOTES:
1. ALLOW 6" MINIMUM CLEARANCE ABOVE THE VENT FAN DISCHARGE
 2. ALLOW 24" MIN. CLEARANCE BELOW DISH TABLE TO SERVICE ELECTRICAL EQUIPMENT

ALL SPECIFICATIONS ARE SUBJECT TO CHANGE WITHOUT NOTICE

9200-03577 RevAC

TABLE CONNECTION

NOTE:
VENT COWLS
ARE REMOVABLE
TO ASSIST IN THE
PLACEMENT OF
DISH TABLES

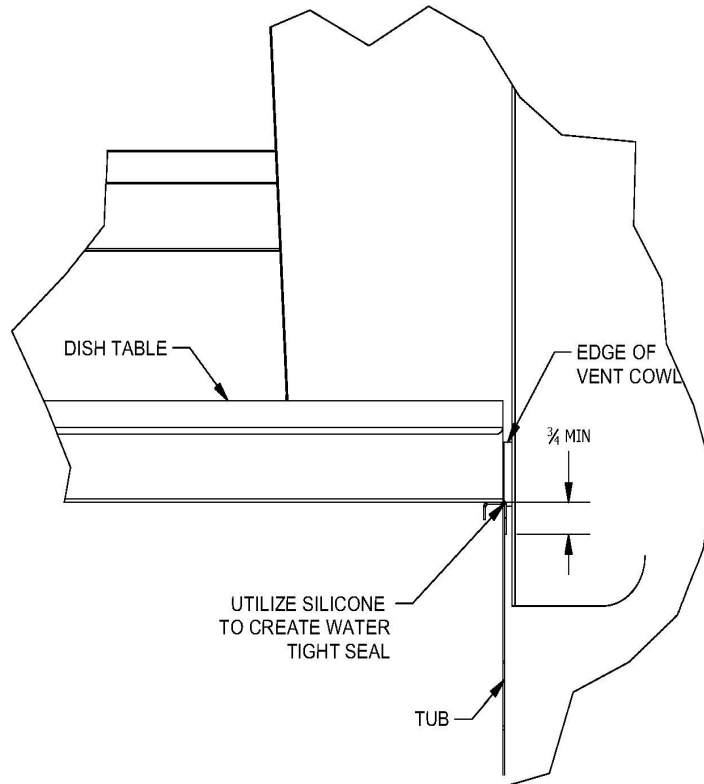
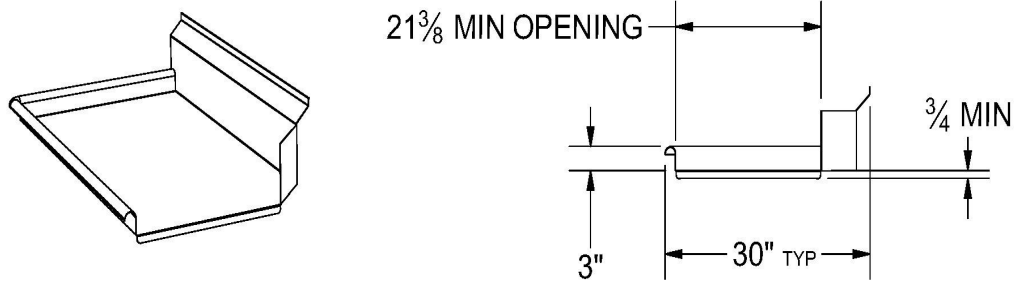

ADMIRAL RACK CONVEYOR SERIES

INTRODUCTION

Purpose

The purpose of this technical manual is to provide installation, operation, cleaning and maintenance directions.

A section is provided for replacement parts.

Scope

This manual contains all pertinent information to assist in the proper installation, operation, cleaning, maintenance, and parts ordering for Insinger Rack Conveyor Admiral Dishwasher Series.

The **installation instructions** are intended for qualified equipment installers. The **operation and cleaning instructions** are intended for the daily users of the equipment. The **maintenance and parts sections** are intended for qualified service and/or maintenance technicians. Replacement parts may be ordered directly from our factory or from your local Insinger Authorized Service Agency. You can speak to the **Insinger Technical Services Department, 800/344-4802**, or e-mail us at **service@insingermachine.com**. When calling for warranty information or replacement parts please provide the model and serial number of your Insinger Equipment. These important numbers should be noted in this manual on the spaces provided on the opening page.

Surefire™ Start-up & Check-out Program

Insinger is proud to offer our exclusive Surefire™ Start-up & Check-out Program to our commercial customers. This service is included in the purchase price of your new Insinger dishwasher. We will provide an authorized factory service technician for the initial start-up of your new Insinger dishwasher to ensure it is running at optimum levels from the very first pass. Please call the factory or your local Insinger Sales Representative to schedule this service.

NSF 3-2003 requirements for detergent and chemical sanitizer dispensers.

This machine must be operated with an automatic detergent dispenser and, if applicable, an automatic chemical sanitizer feeder, including a visual means to verify that detergents and sanitizers are delivered or a visual or audible alarm to signal if detergents and sanitizers are not available for delivery to the respective washing and sanitizing systems. Please see instructions for electrical and plumbing connections located in this manual and in the feeder equipment manual.

Definitions

Throughout this guide you will find the following terms: **WARNING**, **CAUTION**, & **NOTE**.

WARNING indicates potential physical danger.
CAUTION indicates potential equipment damage.
NOTE indicates helpful operating hints or tips.

You will visually be able to identify each as shown below:



WARNING:

Indicates potential physical danger.



NOTE:

Indicates helpful operating hints or tips.

CAUTION:

Indicates potential equipment damage.

INSINGER MACHINE COMPANY LIMITED WARRANTY

Insinger Machine Company, Inc. (Insinger) hereby warrants to the original retail purchaser of this Insinger Machine Company, Inc. product, that if it is assembled and operated in accordance with the printed instructions accompanying it, then for a period of either 15 months from the date of shipment from Insinger or 1 year (12 months) from the date of installation, that said Insinger product shall be free from defects in material and workmanship. Whichever one of the two aforesated limited warranty time periods is the longest shall be the applicable limited warranty coverage time period.

Insinger may require reasonable proof of your date of purchase; therefore, you should retain your copy of invoice or shipping document.

This limited warranty shall be limited to the repair or replacement of parts which prove defective under normal use and service and which on examination shall indicate, to Insinger's satisfaction, they are defective. Any part that is claimed to be defective and covered by this limited warranty must be returned to Insinger, this may be done through an Authorized Service Agency. Furnish serial number of machine with shipment and send to:

*Insinger Machine Company
6245 State Road
Philadelphia, PA 19135-2996*

If Insinger's inspection confirms the defect and the claim, Insinger will repair or replace such part without charge and return it to you freight or post-age prepaid.

This limited warranty does not cover any failure or accident, abuse, misuse, alteration, misapplication, improper installation, fire, flood, acts of God or improper maintenance or service, or failure to perform normal and routine maintenance as set out in

the instruction booklet (operating instructions) or for improper operation or failure to follow normal operating instructions (as set out in the instruction booklet). Insinger is not responsible nor liable for any conditions of erosion or corrosion caused by corrosive detergents, acids, lye or other chemicals used in the washing and or cleaning process.

Service must be done by either Insinger Appointed Service Agencies or agencies receiving prior authorization from Insinger.

All warranty work must be done during normal working hours, unless purchaser receives prior authorization from Insinger.

There are no other express warrants except as set forth herein and any applicable implied warranties of merchantability and fitness are limited in duration to the period of coverage of this express written limited warranty. This limited warranty supersedes all other express warranties, implied warranties of merchant-ability and fitness or limited warranties as of this date, January 1, 1998. Some states do not allow limitation on how long an implied warranty lasts so this limitation may not apply to you.

Insinger is not liable for any special, indirect or consequential damages. Some states do not allow the exclusion or limitation of incidental or consequential damages, so this limitation nor exclusion may not apply to you.

Insinger does not authorize any person or company to assume for it any other obligation or liability in connection with the sale, installation, use, removal, return or replacement of its equipment: and no such representations are binding on Insinger.

**INSINGER MACHINE COMPANY LIMITED WARRANTY
COMMERCIAL MARINE USE**

Insinger Machine Company, Inc. (Insinger) hereby warrants to the original retail purchaser of this Insinger Machine Company, Inc. product, that if it is assembled and operated in accordance with the printed instructions accompanying it (installation manual), then for a period of 18 months from the date of installation on board the vessel, that said Insinger product shall be free from defects in material and workmanship.

Insinger may require reasonable proof of your date of equipment install, therefore, you should retain your copy of invoice or shipping document.

This limited warranty shall be limited to the replacement of parts which prove defective under normal use and service and which on examination shall indicate, to Insinger's satisfaction, they are defective. Any part that is claimed to be defective and covered by this limited warranty must be returned to Insinger. Furnish serial number of machine with shipment and send to:

*Insinger Machine Company, Inc.
6245 State Road
Philadelphia, PA 19135-2996*

If Insinger's inspection confirms the defect and the claim, Insinger will repair or replace such part without charge and return it to you freight or postage prepaid. If part damages are not covered, Insinger will contact the customer and advise.

If a factory trained authorized technician is required to repair or replace defective parts or material during the 18 month warranty period, the cruise line will be responsible for the payment of travel expense and a minimum of four hours labor.

Labor will be billed to the customer at a reduced rate of \$40.00 per hour. If sailing with a vessel is required, then an eight hour per day minimum will apply.

This limited warranty does not cover accident, abuse, misuse, alteration, misapplication, improper installation, fire, flood, or improper maintenance or service, or failure to perform normal and routine maintenance as set out in the instruction booklet (operating instructions) or for improper operation or failure to follow normal operating instructions (as set out in the instruction booklet).

Insinger is not responsible nor liable for any conditions of erosion or corrosion caused by corrosive detergents, acids, lye or other chemicals used in the washing, caring and or cleaning process.

Warranty service must be done by either Insinger Appointed Service Agencies or agencies, customers galley engineers receiving prior authorization from Insinger.

There are no other express warrants except as set forth herein and any applicable implied warranties of merchantability and fitness are limited in duration to the period of coverage of this express written limited warranty. This limited warranty supersedes all other express warranties, implied warranties of merchantability and fitness or limited warranties as the above date.

Insinger does not authorize any person or company locally or overseas to assume for it any other obligation or liability in connection with the sale, installation, use, removal, return or replacement of its equipment; and no such representations are binding on Insinger.

INSTALLATION INSTRUCTIONS**Placement**

Carefully uncrate machine. Take caution not to damage components which may be mounted on the top or sides of the machine. Set unit in place and adjust the feet to level the machine.

Fasten the tables to the load and unload side of the machine. Most installations require fastening the turn-down lip of the dish table to the side of the machine with flathead counter-sunk screws. The table design should provide horizontal clearance of 30" for servicing underneath the table.

Electrical Connections

Connect electrical lines sized for the correct voltage, current and phase of the machine. These should agree with the machine requirements indicated on the nameplate and labels on the control panel.

On machines not provided with a single-point connection (optional) there is an electrical connection required for the: **1.** Pumps and control circuit, **2.** Wash tank heater(s) and, **3.** Rinse tank heaters (if provided).

If an external electric booster is provided, connect power directly to the booster.

Fusing must be in accordance with the Fuse Sizing Chart on specification sheet.

CAUTION:

Connections must be made to a circuit breaker or fused disconnect as provided by the end-user and required by local codes.

A wiring diagram is inside the control panel.

CAUTION:

As with any 3 phase system, an electrician must check all motors for proper phasing, i.e., pump motors must be running in direction indicated by arrow on housing.

Mechanical Connections

Connect water lines for tank fills as tagged and noted on the installation drawings.

If machine is provided with steam heat connect the steam lines and steam condensate lines as tagged and noted on installation drawings. If machine is provided with gas heat, connect the gas line.

If a booster is provided a hot water connection is necessary (110° F or 140° F).

CAUTION:

Drain lines must be as specified on installation drawings.

Drain line should be properly vented and should have fall of not less than 1/4" to the foot of proper flow.

Some area plumbing codes require drains to flow into an open gap with an opening twice the diameter of the pipe.

Check with your local plumbing codes for the type of drain connection required.

CAUTION:

All lines must be flushed prior to use to remove debris.

CAUTION:

Do not reduce the size of lines as specified in installation drawings. All lines are sized to facilitate necessary flows, pressures, etc.

HVAC

The ventilation system should be sized to provide adequate ventilation per machine specs. Refer to spec sheet.

Stainless steel, watertight ducting should be connected to the vent cowls (optional) on each end of the machine.

Chemicals

Upon the completed installation of the dishwasher, contact a local detergent/chemical supplier for the correct chemicals for your soil load and geographical area.

Electrical connection points for the detergent dispenser and rinse injector are located inside the control panel. Refer to the wiring diagram for this machine for the proper connection points.

Dispensers may be connected on either the primary voltage side of the machine or the 24VAC control voltage side.

CAUTION:

When connecting on the 24VAC control voltage side of the transformer, total VA *must* not exceed 5Kva.

The detergent density probe can be placed in the provided hole (labeled "Detergent Probe") in the wash tank.

Tabling

Load and unload tables should be pitched towards the machine to return excess water into the machine.

CAUTION:

Machines with unload tables less than 48" should utilize a rack limit switch to shut the machine down if clean racks pile-up. This extends the life of the drive system.

Final Rinse Pressure Adjustment

1. The final rinse pressure must be adjusted to 20PSI. This is done by adjusting the pressure regulator.

Insinger dishmachines are user-friendly, making them the easiest dishmachines on the market to operate and maintain.

By following these operating procedures your Insinger dishwasher will give you years of trouble free service.

OPERATION INSTRUCTIONS

1. Ensure drain stopper is in place. Close all tank drain valves. One drain is provided for each tank of the dish machine.
2. Check for proper installation and cleanliness of all internal, removable components such as suction strainers, scrap screens, and spray manifolds.
3. Ensure all water, steam, and gas lines are open. Ensure electrical circuits are on.
4. Close machine doors.

**NOTE:**

An interlock is provided to shut the machine down if the doors are open, therefore the machine will not run if the doors are opened.

5. Press Power Button.
6. The machine will begin to fill (LED bar will light up blue as the tank fills) LED bar will change to orange as the machine heats.
7. When the tanks are full the tank heat will operate automatically (LED bar will change to orange as the machine heats).

CAUTION:

To ensure proper operation of the auto tank fill feature and the tank heaters, the tank level floats **MUST** be cleaned daily.

8. Once machine reaches minimum wash tank temperature LED bar will change to green and display will read READY.
9. The system is now ready for operation. All ware should be properly scrapped. Do not overload racks.

**NOTE:**

If machine is idle for 50 minutes machine goes into idle mode, LED bar will be white.

CAUTION:

Overloading racks will impede proper cleaning of the ware and also put extra strain on the conveyor system.

10. Slide the rack into the dish machine, the conveyor will start (LED bar will chase side to side in Blue color to indicate machine is operational).
11. Rack will pass through the various machine cycles then machine will turn off. (as long as racks are present inside machine, machine will remain operational)
12. Should a conveyor jam occur, the CONVEYOR JAM will be displayed, LED bar will blink red, and the machine will shutdown. To re-start the machine, clear the conveyor jam. If jam is severe press power button then remove jam. Door will need to be opened and closed as indicated in display.
13. Press POWER switch to turn OFF machine. LED bar will Blink RED and Display DRAIN MACHINE. (Machine must be drained in order to power off (LED bar in blue will go off as machine drains)
14. Refer to the cleaning procedures for proper cleaning of the dish machine.
15. Report any unusual occurrences to qualified service personnel.

Initial Start-Up Adjustments

Final Rinse Pressure Adjustment

1. The final rinse pressure must be adjusted to 20PSI. This is done by adjusting the pressure regulator.

Temperature Adjustment

1. Open control box cover. Open front door then press and hold button 4 on membrane switch located inside control box for 3 seconds.
2. Use button 3 to scroll to desired temperature (WASH TEMP or RINSE TEMP).
3. Change value using button 1 or 2.
4. Select button 4 to save change / exit.

**NOTE:**

Temperatures are preset at factory for optimal operation.

The following cleaning procedures should be done daily, at the end of the shift.

DAILY CLEANING PROCEDURES

1. Remove all internal removable parts including spray manifolds, scrap screens, drain overflow, suction strainers and curtains.
2. Remove the end caps from the spray manifolds and clean with the brush provided. Flush the manifolds.
3. Flush scrap screens.
4. Clean drain overflow tube.

**NOTE:**

V-cup seal on the drain overflow may become gummed not allowing the overflow tube to seal. This will cause the drain to leak water. Remove any build-up on the V-cup seal. When the seal becomes worn, replace with part # 4025-01541.

5. Clean the suction strainers of build-up.

**NOTE:**

Improper cleaning of the suction strainers will cause the pumps to cavitate. This will cause poor washing results.

6. Clean the tank level cup with a plastic abrasive pad (do not use steel wool).

**NOTE:**

Level cup must be cleaned daily. Build-up of grease and dirt will cause faulty operation of the tank fill heating system.

The LIQUID LEVEL CUP is located below the scrap screens in those tanks which contain water heating devices (coils, steam injectors, or electric immersion heaters) and pump inlet strainers. They are usually located, in rackless and rack conveyor style machines, on the inside tank wall opposite and parallel to the inspection doors

7. Clean curtains. When the curtains are beyond cleaning or torn they should be replaced.
8. Clean final rinse nozzles of matter clogging the jet spray.
9. Leave the doors open to allow the drying of the interior surfaces.

WEEKLY CLEANING PROCEDURES

A DELIME switch is provided on the control panel. Switch has three horizontal bars and is right of power switch. Press and hold (5 seconds) DELIME switch will start the delime cycle. The LED's will be magenta in color. Consult your detergent supplier for de-liming solution concentration and frequency of use.

**NOTE:**

Delime cycle is to be started after initial fill. If machine has already been on drain machine and restart before entering delime cycle.

The following is a basic guide for the repair and replacement of common dishwasher parts. Refer to the Basic Services Guide for troubleshooting tips.

MAINTENANCE REQUIREMENTS

Daily

1. Refer to the operations and cleaning instructions provided in this manual for daily cleaning procedures.

Weekly

1. The entire machine should be wiped down using an industrial grade stainless steel cleaner.
2. Under the supervision of your detergent supplier the machine interior must be properly de-limed.
3. A switch is provided on the control panel to run the DELIME cycle. Switch is to the right of power switch with three horizontal bars.

**NOTE:**

The water quality in some areas requires de-liming to be done more frequently. Contact your detergent supplier for recommended de-liming frequency.

Quarterly

1. Remove and clean the strainer screens on the water and steam lines. If the screens cannot be cleaned, replace.
2. Inspect the condition of the solenoid valve seats, and diaphragms. Replace where necessary.
3. Inspect drain O-Rings for leakage. Replace where necessary.
4. Check belt for wear.
5. Adjust conveyor chain tension using adjustment bolts located on the exit ends of the machine.

MAINTENANCE PROCEDURES

Solenoid Valve Disassembly

1. Disconnect the power supply to the machine. Turn off the water supply.
2. Remove cap on top of the coil. Remove the coil.
3. Remove the 4 hex bolts and lift bonnet from valve body. Note positioning of spring and plunger.
4. Remove main piston.
5. Inspect for dirt, wear or lime build-up. Clean or replace as required.
6. Reassemble in reverse of disassembly.

Liner Strainer Disassembly

1. Shut off water or steam supply.
2. Remove large hex nut on bottom of strainer body.
3. Remove strainer screen. Inspect and clean or replace as necessary.
4. Reassemble in reverse of disassembly. Water flow must be same direction as arrow on line strainer body. Use new gaskets to insure a tight seal.

Pump Disassembly

1. Before disassembling pump ensure there are no obstructions in the pump intake. Remove and clean the suction strainer (inside tank).

**NOTE:**

It is not necessary to remove the pump housing from the machine to disassemble pump.

2. Remove the pump motor and impeller by removing the 8 socket head screws attaching them to the pump housing.
3. Repair or replace the pump parts as required.
4. Reassemble in reverse of disassembly.

MAINTENANCE PROCEDURES**Immersion Heater Replacement**

1. The immersion heater **MUST** be completely submerged at all times. If this is not the case contact a qualified service technician. The heated surface should never be in contact with sludge.
2. Remove front panel from machine.
3. Disconnect the immersion heater wires.
4. Remove the immersion heater.
5. Install in reverse of removal.

Heater Temperature Adjustment

1. Open control box cover. Open front door then press and hold button 4 on membrane switch located inside control box for 3 seconds.
2. Use button 3 to scroll to desired temperature to adjust (Wash or Rinse).
3. Change value using button 1 or 2.
4. Select button 4 to save change / exit.

**Troubleshooting Tank Temperatures
Electric Heat**

1. Verify tank heat contactor is working correctly. If not, replace.
2. Verify all immersion heaters are working properly and not limed. If not, replace.
3. Verify control board is sending signal to heater contactor.

Steam Heat

1. Verify steam pressure per machine specifications.
2. Verify steam trap is not clogged. If so, replace.
3. Verify control board is sending signal to solenoid.

Motor Overloads

All motors used on Insinger Machines are provided with motor overloads. Motor overloads are adjusted when the machines are factory tested. Should it be necessary to adjust the motor overloads in the field first verify the motor current draw for the voltage the machine is using.

Adjust by turning the dial to the appropriate AMP draw.

Machine Start Actuator

The wash, rinse, and drive are actuated by a lever located on front rack rail at entrance of machine. When a rack depresses it a timer is set as that the rinse, wash and drive will stop once rack passes final rinse arm.

NOTE:
 Dirty float cu will cause the tank heat to energize with no water in the tanks.
LEVEL CUP MUST BE CLEANED DAILY.

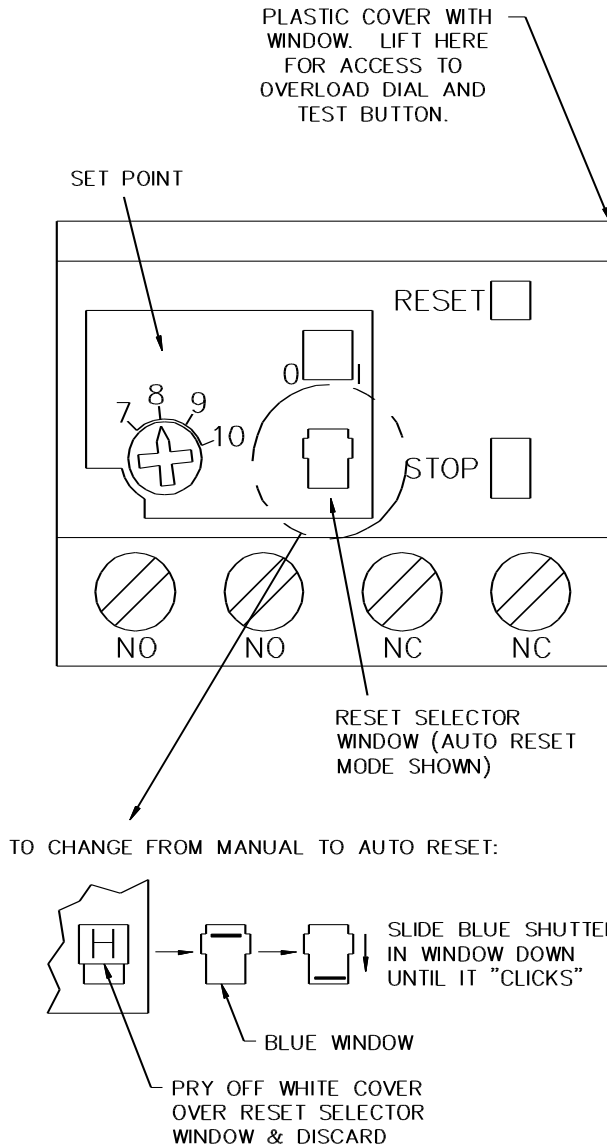

SKETCHA\SK-3829 OVERLOAD RELAY

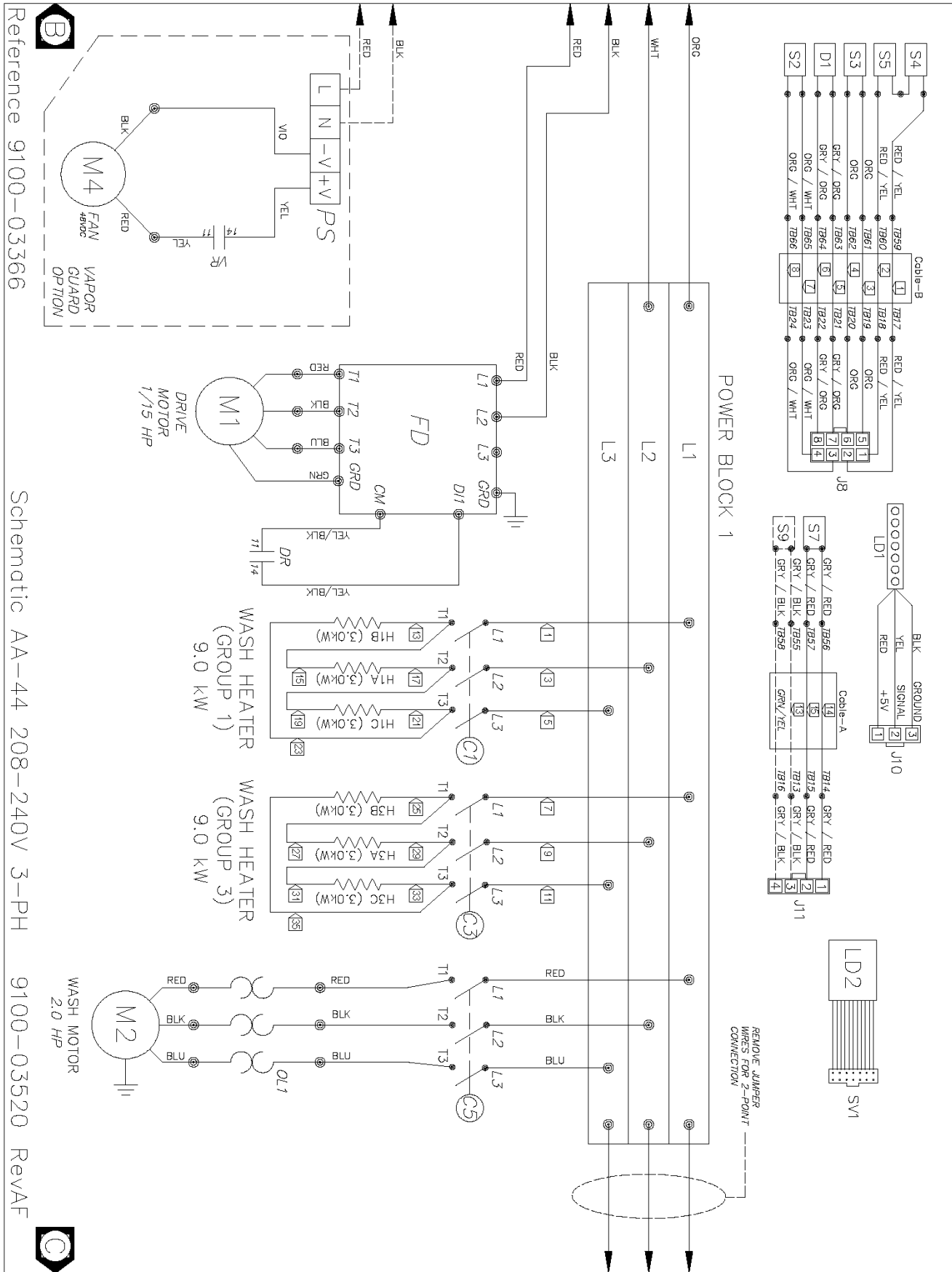

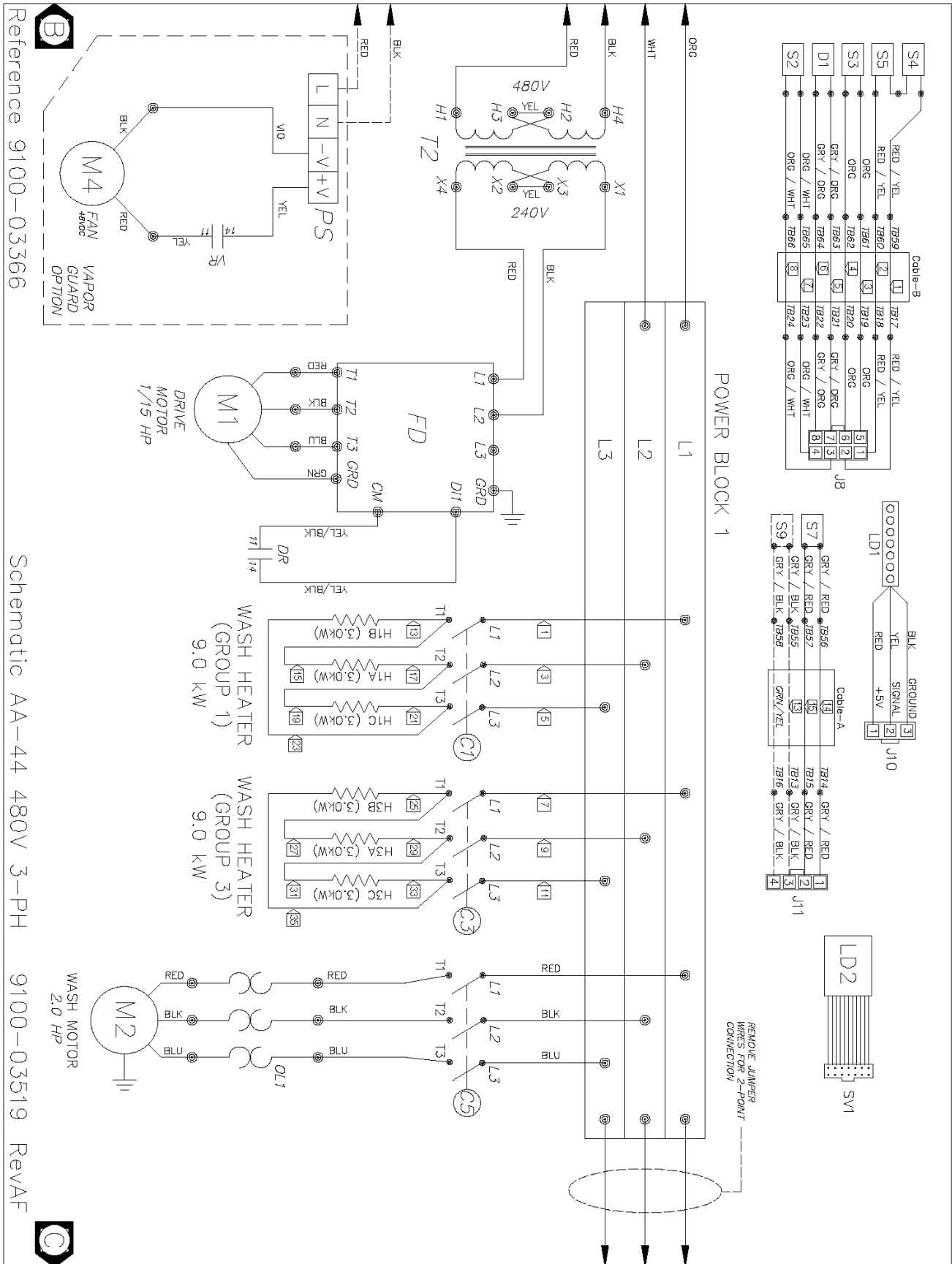

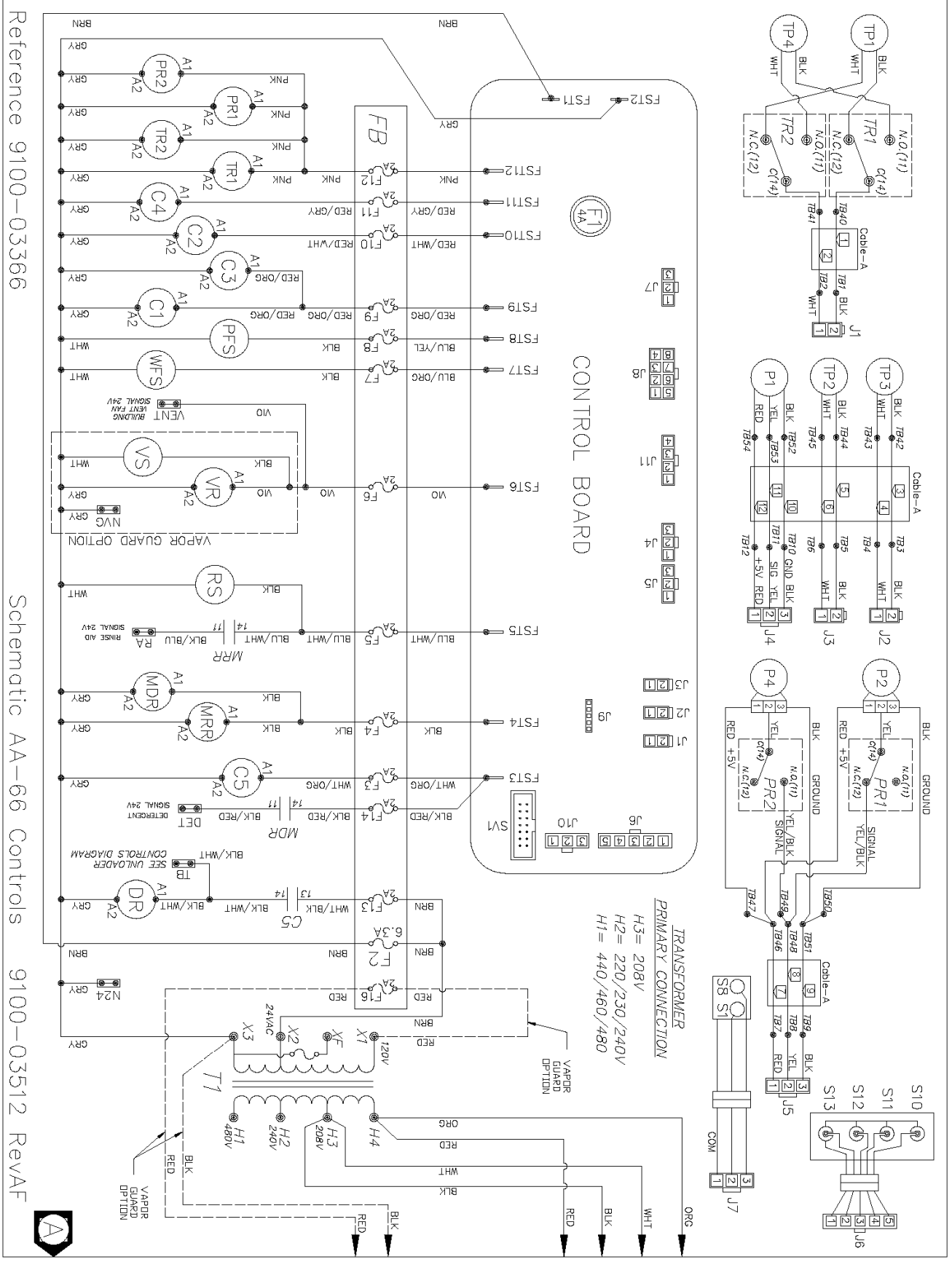

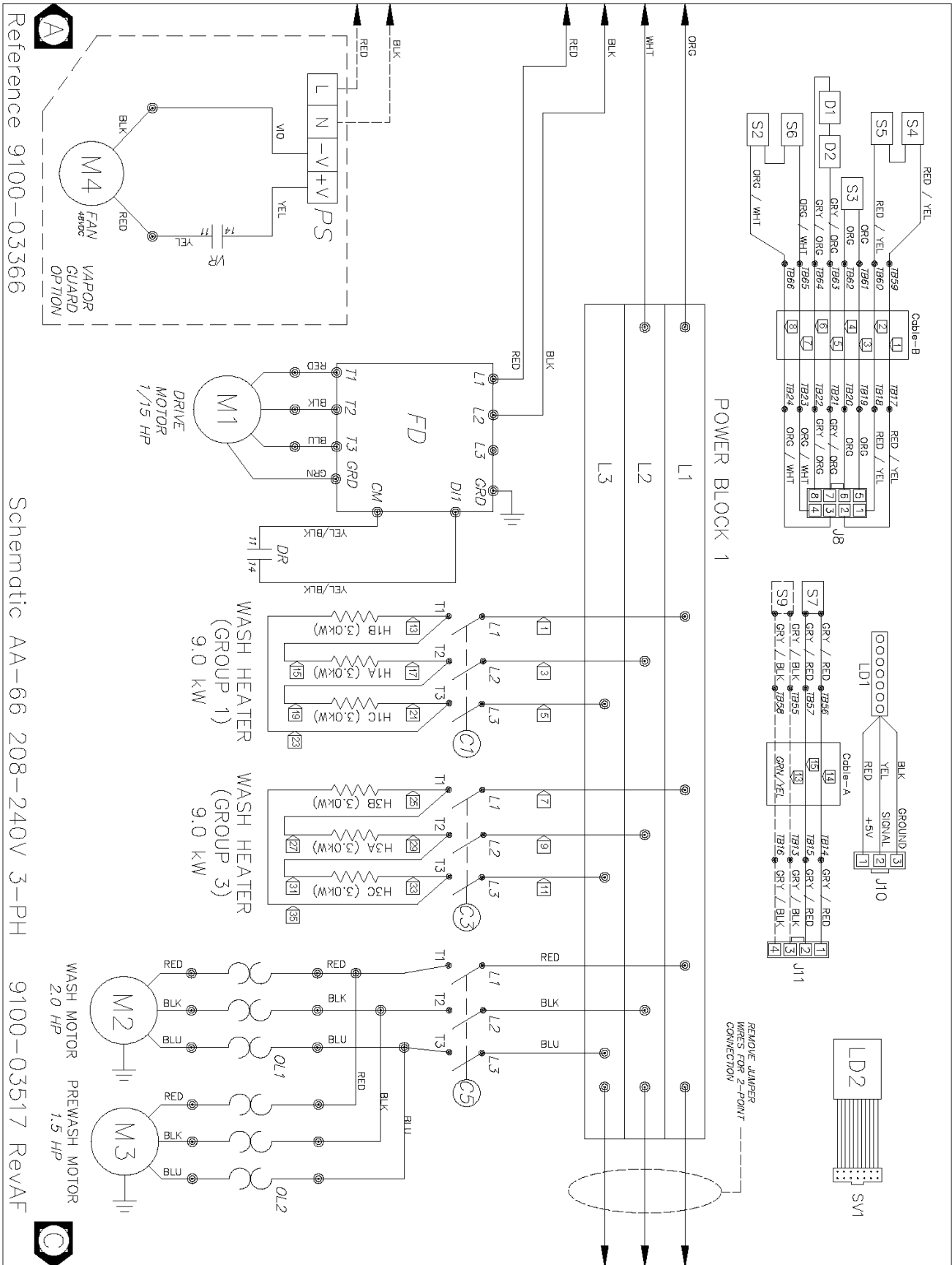

Reference 9100-03366

Schematic AA-66 208-240V 3-PH

9100-03517 RevAF



Reference 9100-03366

Schematic AA 3-Phase Booster & Legend

9100-03559 RevAF

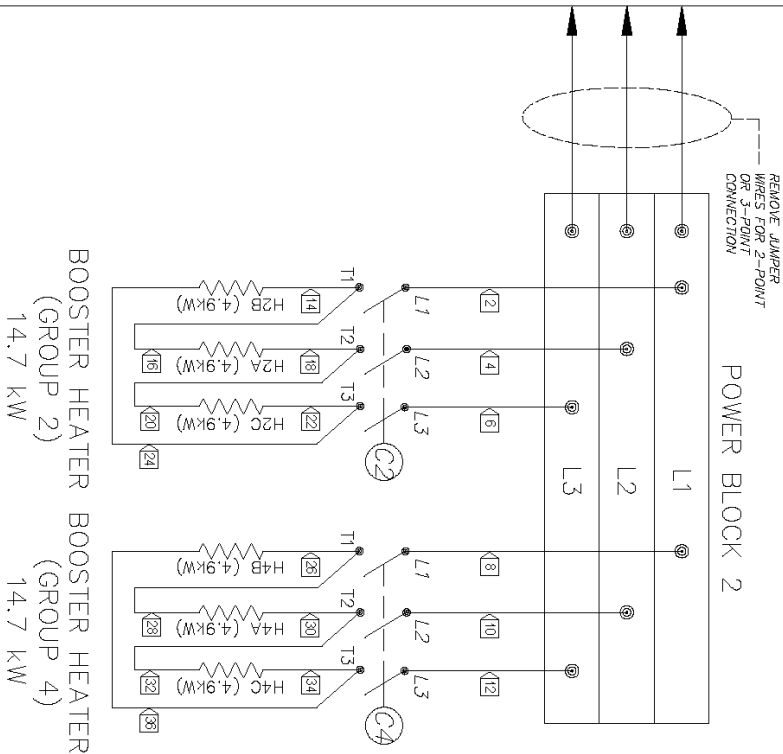

BOOSTER HEATER BOOSTER HEATER
(GROUP 2) (GROUP 4)
 14.7 kW 14.7 kW

NOTE:
 * 66 Units Only
 ** 480 Volt Units Only
 *** Vapor Guard Units Only

LEGEND	
M1	DRIVE MOTOR
M2	WASH MOTOR
* M3	PRE-WASH MOTOR
*** M4	EXHAUST FAN
LD1	LED Bar
LD2	Display/2x20 OLED
S1	Manual / Deline
S2	Door Switch
S3	Rock Switch
S4	High Limit Switch 1
S5	High Limit Switch 2
* S6	Pre-Wash Door Switch
S7	Conveyor Jam Switch
S8	Power Switch ON/OFF
S9	Table Limit Switch
S10	Button 1 - Change Value +
S11	Button 2 - Change Value -
S12	Button 3 - Scroll to Select
S13	Button 4 - Enter / Exit
D1	Drain Switch - Wash
* D2	Drain Switch - PreWash
TP1	Wash Tank Temperature
TP2	Rinse Temperature Outlet
TP3	Rinse Temperature Inlet
* TP4	Prewash Tank Temperature
P1	Rinse Pressure Transducer
P2	Wash Level Transducer
* P4	PreWash Level Transducer
* TP1	Temperature Switch Relay 1
* TR2	Temperature Switch Relay 2
* PR1	Pressure Switch Relay 1

* PR2	Pressure Switch Relay 2
T1	Control Transformer
** T2	Drive Transformer (480V)
C1	Wash Heater Contactor
C2	Booster Heater Contactor
C3	Wash Heater Contactor
C4	Booster Heater Contactor
C5	Motor Contactor
DL1	Overload-Wash Motor
* DL2	Overload-PreWash Motor
RS	Rinse Solenoid
* PFS	Pre-Wash Fill Solenoid
WFS	Wash Fill Solenoid
MDR	Manual Relay Detergent
MRR	Manual Relay Rinse
DR	Drive Relay
MRR	Manual Relay Rinse
DR	Drive Relay
FD	Frequency Drive
FB	Fuse Blocks
F1	Fuse-Controll Board (4 amp)
F2	Fuse-Controll Board (7 amp)
F3-F16	Fuses to Component (2 amp)
DET	Detergent Signal Block 24V
RA	Rinse Aid Signal Block 24V
FAN	Vent Fan Signal Block 24V
N24	Neutral for Signal Block 24V
*** VS	Vapor Cooling Solenoid
*** VR	Vent Recovery Relay
*** PS	Power Supply

HOURS OF OPERATION

Insinger is available to assist you and your team day or night. Our regular business hours are Monday through Friday, 8:00 AM - 5:00 PM (EST). After-hours inquiries may take longer to respond.

CONTACTS

SALES

Kim Croft
Director of Business Development
E: kcroft@insingermachine.com
D: (215) 624-4800 x124
C: (630) 400-3656

David Baysinger
Regional Sales Manager
E: dbaysinger@insingermachine.com
D: (215) 624-4800 x111

ORDERS & QUOTES

Edward Gerhard
Account Manager
E: egerhard@insingermachine.com
D: (215) 624-4800 x116

Deniece Heard
Customer Service
E: dheard@insingermachine.com
D: (215) 624-4800 x120

MARKETING

Matthew Weisbecker
Strategic Marketing Manager
E: mweisbecker@insingermachine.com
D: (215) 624-4800 x131

SERVICE & SUPPORT

Jason Striker
Parts & Service Manager
E: jason@insingermachine.com
D: (215) 624-4800 x139

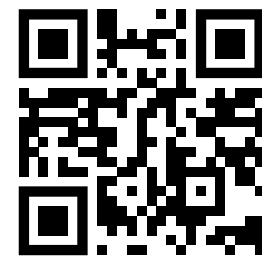

Digital Contact Cards



215.624.4800 | insingermachine.com | 6245 State Rd., Philadelphia. PA 19135