



CENTURY

Technical Manual

Century (14') | Century (17')





Thank you for Purchasing this quality Insinger product.

On the space provided please record the Model and Serial Number of this unit:

Model: _____

Serial Number: _____

When referring to this equipment please have these numbers available.

Each piece of equipment at Insinger is carefully tested before shipment for proper operation. If the need for service should arise please contact your local Authorized Insinger Service Company. A Service Network Listing is provided within this manual. Check this list for your local authorized servicer.

For proper activation of the *Insinger Limited Warranty* a SureFire™ Start-up should be completed on your machine. Refer to the Introduction section in this manual for an explanation of Insinger's SureFire™ Start-up and Check-out Program.

Please read the Insinger Limited Warranty and all installation and operation instructions carefully before attempting to install or operate your new Insinger product.

To register your machine for warranty by phone, fax, or the internet or for answers to questions concerning installation, operation, or service contact our Technical Services Department:

Toll-Free	800.344.4802
Fax	215.624.6966
Email	service@insingermachine.com
World-Wide Web	http://www.insingermachine.com

Thank you.
Insinger Machine Company

S:\WP51\MANUAL\INTRO



FLIGHT TYPE DISHMACHINES
Century 14 & Defender Series
Table of Contents

PART 1 - TECHNICAL INFORMATION

- * Introduction
- * Catalogue Cut-sheet and Installation Drawing
- * Warranty

PART 2 - INSTALLATION AND OPERATION INSTRUCTIONS

- * Section A, Installation Instructions
- * Section B, Operation and Cleaning Instructions

PART 3 - MAINTENANCE AND REPAIR PROCEDURES

- * Section A, Maintenance and Repair Procedures
- * Basic Service Guide

PART 4 - ELECTRICAL SCHEMATICS AND REPLACEMENT PARTS

- * Machine Wiring Diagrams
- * Control Panel Layout and Component Drawing
- * Electric Blower Dryer Wiring Diagram
- * Electric Blower Dryer Control Panel Layout & Control Panel Layout
- * Electric Booster Wiring Diagram

PART 5 - REPLACEMENT PARTS

Model: Century 14

- * Overall Assembly Drawing
- * Track Installation Assembly's
- * Baffle & Scrap Screen Assembly's
- * Driven Shaft Assembly
- * Curtain & Baffle Installation Assembly's
- * Discharge Line Assembly's
- * Final Rinse Assembly
- * Auto Tank Fill Assembly
- * Conveyor Drive Assembly
- * Drain Assembly's
- * Pump Assembly
- * Pump Suction Assembly
- * Liquid Level Float Typical Installation
- * Start/Stop Station Assembly
- * Rack Section Details
- * Photoelectric Eye Installation



FLIGHT TYPE DISHMACHINES
Century 14 & Defender Series
Table of Contents

PART 5 - REPLACEMENT PARTS, CONT'D

Model: Defender series

- * Overall Assembly Drawing
- * Track Installation Assembly's
- * Baffle & Scrap Screen Assembly's
- * Curtain & Baffle Installation Assembly's
- * Discharge Line Assembly's
- * Final Rinse Assembly
- * Auto Tank Fill Assembly
- * Cold Water Thermostat/Load Flush Piping
- * Conveyor Drive Assembly
- * Conveyor Overload Shutoff Assembly
- * Driven Shaft Assembly
- * Drive Shaft Assembly
- * Stop Bar Assembly & Location
- * Drain Assembly's
- * Pump Assembly
- * Liquid Level Float Typical Installation
- * Steam Piping (injectors & coils)
- * Rack Section Details
- * Photoelectric Eye Installation
- * Accessory Locations
- * Assembly - Hood Top Light, mechanical connections



CENTURY 14 & DEFENDER SERIES
TECH MANUAL INTRODUCTION
Part 1, Section A

A. INTRODUCTION

A.1 Purpose

The purpose of this Tech Manual is to provide installation, operation, cleaning and maintenance directions. A section is provided for replacement parts.

A.2 Scope

This manual contains all pertinent information to assist in the proper installation, operation, cleaning, maintenance, and parts ordering for the Century 14 and Defender Series dishwashers. The installation instructions are intended for qualified equipment installers. The operation and cleaning instructions are intended for the daily users of the equipment. The maintenance and parts sections are intended for qualified service and/or maintenance technicians.

Replacement parts may be ordered directly from our factory or from your local Insinger Authorized Service Agency. For the name of your local Insinger Authorized Service Agency please reference the Service Network Listing in Section 1 of this manual. You can also speak to the Insinger Technical Services Department, 800/344-4802, or e-mail us at service@insingermachine.com. When calling for warranty information or replacement parts please provide the model and serial number of your Insinger equipment. These important numbers should be noted in this manual on the spaces provided on the opening page.

A.3 Start-Up Program

Insinger is proud to offer our exclusive Surefire™ Start-up & Check-out Program to our commercial customers. This service is included in the purchase price of your new Insinger dishwasher. We will provide an authorized factory service technician for the initial start-up of your new Insinger dishwasher to ensure it is running correctly. Please call the factory or your local Insinger Sales Representative to schedule this service.

A.4 Definitions

Throughout this guide you will find the following terms: WARNING, CAUTION, & NOTE. When used, these terms will be outlined in a box to draw attention:

WARNING indicates potential physical danger.

CAUTION indicates potential equipment damage.

NOTE indicates helpful operating hints or tips.



PART 1
TECHNICAL INFORMATION



ESSENTIAL SERIES

Project _____
 Item _____
 Quantity _____
 CSI - 11400 _____
 Approval _____
 Date _____

CENTURY Three Tank Rackless Conveyor Dishwasher

- Automatic conveyor, flight type three tank dishwasher with recirculating prewash, wash and rinse; and fresh water final rinse.
- 228 gallons/hour final rinse consumption
- Capacity is 8,725 dishes per hour
- Conveyor speed of 7 feet per minute
- CrossFire® Wash System provides superior cleaning
- Error proof replacement with color-coded curtains
- Designed for left or right hand conveyor travel, as specified

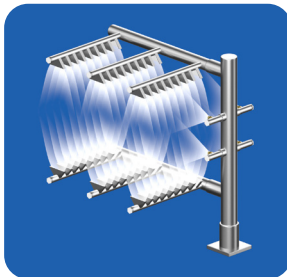

The patented CrossFire® Wash System power sprays water horizontally, as well as, from above and below, cleaning and sanitizing the dirtiest of ware.

STANDARD FEATURES

- CrossFire® Wash System
- SureFire® Start-Up & Check-Out Service
- Tank heat: 50.0 kW electric immersion heaters or steam injectors
- Capillary thermometers for pre-wash, wash, rinse and final rinse
- Final rinse pressure gauge
- Vacuum breaker on all incoming water lines
- Manifold clean-out brush
- Inspection and clean-out doors
- S/S frame, legs and feet
- S/S front enclosure panel
- Automatic tank fill
- Low water protection
- Detergent connection provision
- Top mounted NEMA 12 control panel
- Simplified scrap screen design
- Door safety switch
- Standard frame drip proof motors
- Polypropylene belt with removable rack sections
- Conveyor reversing switch
- Conveyor switch for de-liming
- Interior work lights
- Override switch for de-liming
- End caps/pipe plugs secured to prevent loss
- Color-coded curtains

OPTIONS

- Stainless steel steam coil tank heat
- Steam booster
- Electric booster
- Pressure reduction valve and line strainer
- Single point electrical connection: motors, controls and heaters.
- S/S panels on all sides
- Security package
- Totally enclosed motors
- Insulated hood and door
- Stainless steel belt with removable rack sections





CENTURY

Three Tank Rackless Conveyor Dishwasher

Capacity Per Hour	8736 dishes 600-1300 meals
Tank Capacity	13 gals. (pre-wash) 25 gals. (wash) 26 gals. (rinse)
Motor Size	1/2 hp (pre-wash) 2 hp (wash) 2 hp (rinse) 1/2 hp (conveyor)
Electric Usage	20.0 kW wash tank 30.0 kW rinse tank *24.0 kW booster 40° rise *45.0 kW booster 70° rise
Steam Consumption at 20 psi min.	182 lbs./hour tank 81 lbs./hour booster 40° rise 142 lbs./hour booster 70° rise
Final Rinse Peak Flow at 20 psi min.	3.8 gallons/minute
Final Rinse Consumption at 20 psi min.	228 gallons/hour
Exhaust Hood Requirement	500 CFM Load 1000 CFM unload
Peak Rate Drain Flow	23 gallons/minute
Shipping Weight	2500 lbs.

Machine Electrical		
Motors, Controls Tank Heat	Steam	Electric
208/3/60	21.0	160.0
240/3/60	19.0	139.6
480/3/60	9.5	69.5
380/3/50	11.5	87.5

Contact Insinger Sales at 800-344-4802 for an installation drawing specific to your application. This drawing is available on the Insinger website at www.insingermachine.com

Note: Due to product improvement we reserve the right to change information and specifications without notice.

SPECIFICATIONS

CONSTRUCTION- Hood and tank all welded seamless construction using 16 gauge 18-8 type 304 S/S. S/S frame, legs and feet. All internal castings are non-corrosive nickel alloy, bronze or S/S.

DOORS- Three extra large die formed 18-8 type 304 S/S front inspection doors riding in all S/S channels. A triple ply leading edge on the door channels made of S/S with no plastic or nylon sleeves or liners used. Two intermediate S/S door-safety stops on each door.

CONVEYORS- Removable polypropylene or S/S rack section on S/S belt with polyethylene rollers. Conveyor drive system includes large speed reducer with cut gears operating in oil bath and frictionless, trouble-free overload release system. Conveyor transports dishware automatically through all washing and rinsing systems and is driven by an independent 1/2 hp motor. A trip bar at the end of the unload section stops the conveyor if any ware reaches the bar. A reversing switch is provided to assist in removing jams in the belt.

PUMPS- Centrifugal type "packless" pump with a brass petcock drains. Construction includes ceramic seal and a balanced cast impeller on a precision ground stainless steel shaft, extension or sleeve. All working parts mounted as an assembly and removable as a unit without disturbing pump housing. Two 2 hp motors wash and rinse and 1/2 hp pre-wash, all standard horizontal C-face frame, drip-proof, internally cooled with ball-bearing construction.

CONTROLS- Top mounted control cabinet, NEMA 12 rated with heat insulation provided between hood and control cabinet, housing motor controls and overload protection, transformer, contactors and all dishwasher integral controls. All controls safe low voltage 24 VAC.

ENERGY SAVER- Electric photo eye automatically operates the final rinse solenoid only when ware passes, saving water and energy. The photo eye also activates an adjustable timer control. If no ware passes during the set time, the machine shuts down.

SPRAY SYSTEM- Spray arms made of type 304 stainless steel pipe. Spray assemblies removable without the use of tools.

PRE-WASH- Upper and lower manifolds. One manifold above with 3 power pre-wash nozzles, one manifold below with 3 power pre-wash nozzles.

WASH- Upper and lower manifolds with the patented CrossFire® Wash System. Each manifold has 3 upper and 4 lower power wash arms designed with pressure action cleansing slots. The slots are precision milled for water control producing a fan spray. Wash arms are fillet welded to the S/S manifold. The CrossFire system provides 2 horizontally spraying high pressure nozzles.

RINSE- Upper and lower manifolds. Each manifold has 3 upper and 4 lower power rinse arms designed with pressure action fan spray reducing water consumption, maximizing heat retention.

FINAL RINSE- Eight nozzle assemblies above and four nozzles below threaded into S/S schedule 40 pipes. Nozzle assemblies produce a fan spray reducing water consumption, maximizing heat retention.

DRAIN- Drain valve externally controlled. Overflow assembly with skimmer cap is removable without the use of tools for drain line inspection. Heater is protected by low water level control.

INSTALLATION AND LAYOUT DETAIL

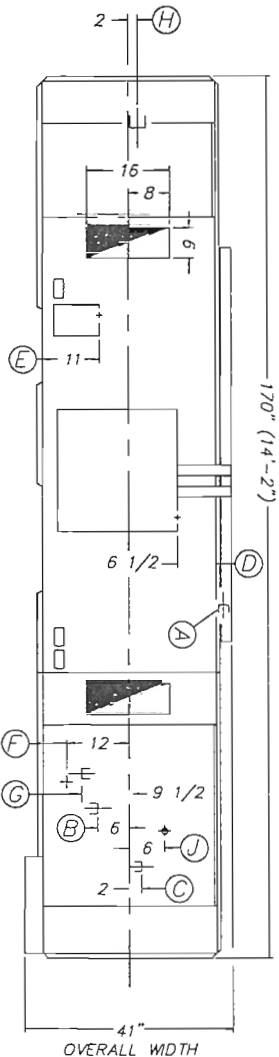
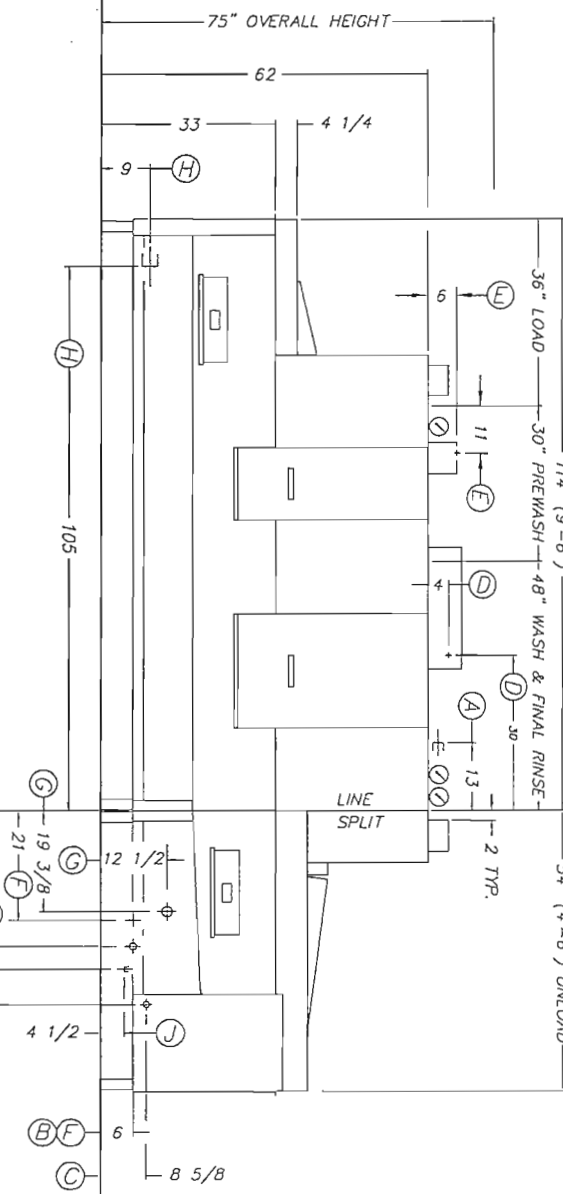
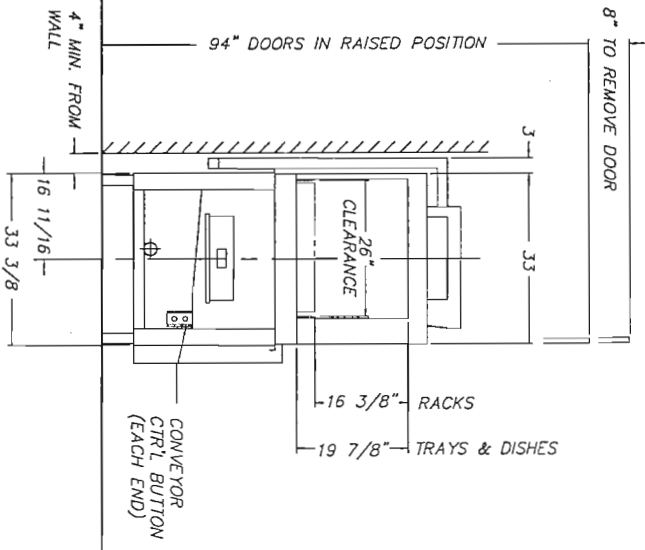

FILE: STD/DEF14L

INSTALLATION CONNECTIONS

LTR	DESCRIPTION	SIZE
A	HOT WATER TO AUTO FILL-140° F	3/4 FIPS
B	HOT WATER TO ELECTRIC BOOSTER *	3/4 FIPS
C	HOT WATER TO STEAM BOOSTER •	3/4 FIPS
D	ELECTRICAL CONNECTION - COMMON	40 KW & 5 1/2 HP
E	ELECTRICAL CONNECTION - LIGHTS	120 V
F	ELECTRICAL CONNECTION - BOOSTER *	27/45 KW
G	STEAM TO BOOSTER AND TANKS	1 1/2 FIPS
H	DRAIN CONNECTION - COMMON	2" FIPS
J	CONDENSATE RETURN - COMMON	3/4 FIPS

NOTES:

1. • • HOT WATER TO BOOSTER 140° F STD/ 110° F SPECIAL
2. (2) 6" X 16" VENTS WITH ADJUSTABLE DAMPERS

LEFT TO RIGHT FEED

△ EGN #1669 3.26.99

DEFENDER 14

AUTOMATIC CONTINUOUS CONVEYOR TYPE DISHWASHING MACHINE



INSINGER
MACHINE COMPANY

6245 State Rd.
Philadelphia PA 19135-2996
Tel: 215-624-4800
Fax: 215-624-6966

SCALE: 1/2" = 1'-0"
DRAWN: EMM 3.4.97
APPROVED: EBA 3.4.97

DWG. NO. DEFENDER 14
DEFENDER A

INSTALLATION AND LAYOUT DETAIL

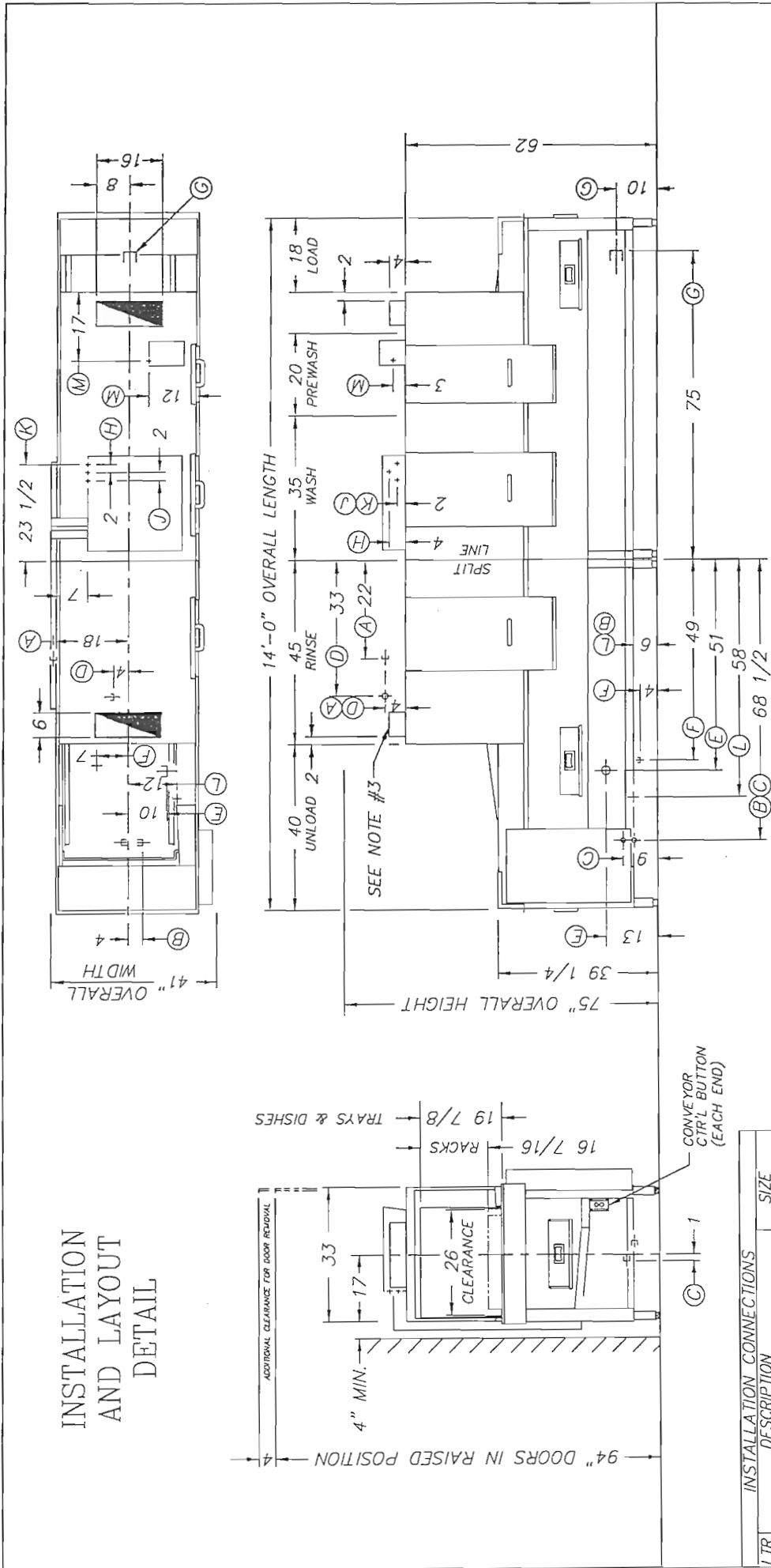

LTR	DESCRIPTION	SIZE
A	HOT WATER TO AUTO FILL - 140° F	3/4 FIPS
B	HOT WATER TO ELECTRIC BOOSTER *	3/4 FIPS
C	HOT WATER TO STEAM BOOSTER •	3/4 FIPS
D	HOT WATER TO FINAL RINSE - 180° F	3/4 FIPS
E	STEAM TO BOOSTER AND TANKS	2 FIPS
F	CONDENSATE RETURN - COMMON	3/4 FIPS
G	DRAIN CONNECTION - COMMON	2 FIPS
H	ELECT. SERVICE - WASH HTRS. *	20 KW
J	ELECT. SERVICE - RINSE HTRS. *	30 KW
K	ELECT. SERVICE - WASHER MTRS.	5 HP
L	ELECT. SERVICE - BOOSTER *	24/45 KW
M	ELECT. SERVICE - LIGHTS	120V

INSTALLATION CONNECTIONS

- NOTES:
- * = FOR ELECTRICALLY HEATED MACHINES ONLY.
 - = HOT WATER TO BOOSTER 140° F STD/ 110° F SPECIAL.
 - (2) 6" x 16" VENTS WITH ADJUSTABLE DAMPERS.

CENTURY 14
 AUTOMATIC CONTINUOUS CONVEYOR TYPE DISHWASHING MACHINE
 Philadelphia, PA 19135
 (215) 624-4800
 FAX (215) 624-6966

Insinger

DRWN: MAM 7.28.93 SCALE: 1/2" = 1'
 REV: EMM 10.27.00
 FILE: STD/CFMT-RH

DWG. NO. CENT-RH
 REV J

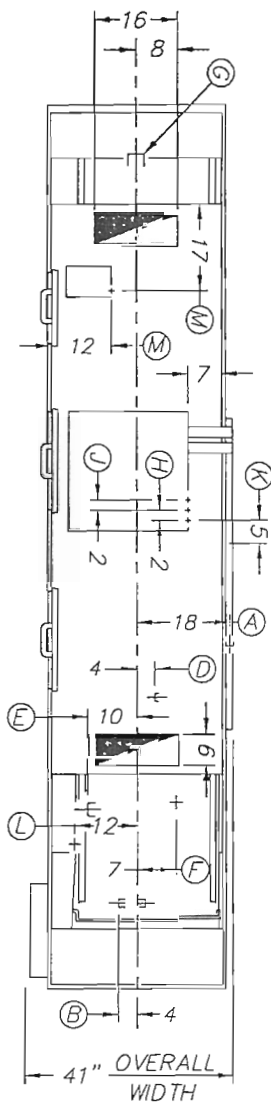

INSTALLATION AND LAYOUT DETAIL

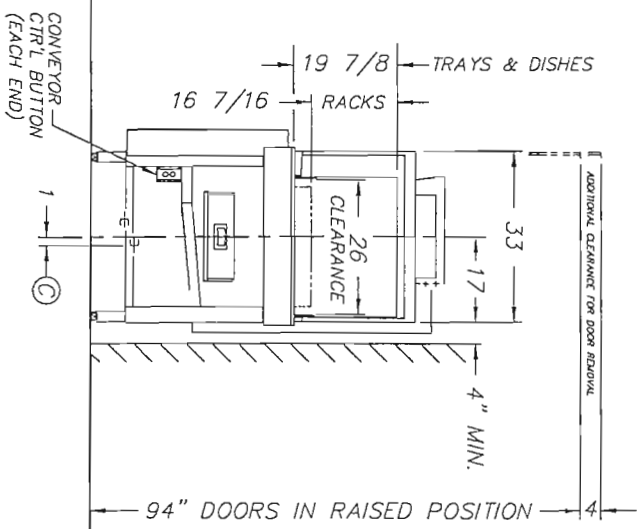
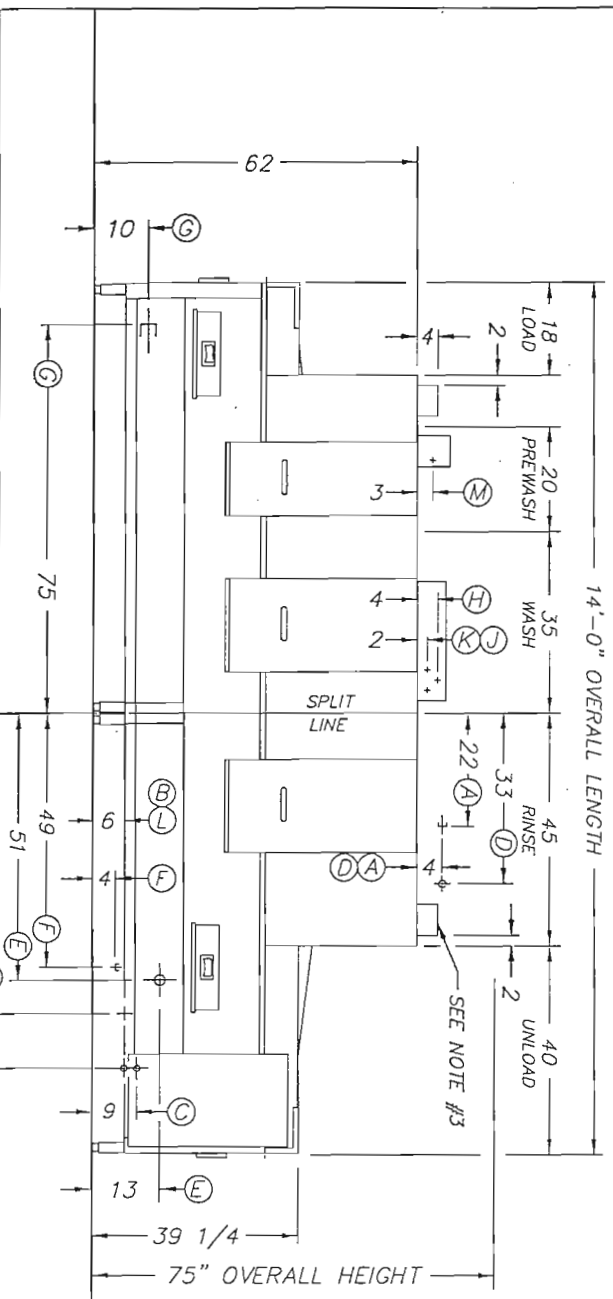

LTR	DESCRIPTION	SIZE
A	HOT WATER TO AUTO FILL - 140° F	3/4 FIPS
B	HOT WATER TO ELECTRIC BOOSTER *	3/4 FIPS
C	HOT WATER TO STEAM BOOSTER •	3/4 FIPS
D	HOT WATER TO FINAL RINSE - 180° F	3/4 FIPS
E	STEAM TO BOOSTER AND TANKS	2 FIPS
F	CONDENSATE RETURN - COMMON	3/4 FIPS
G	DRAIN CONNECTIONS	2 FIPS
H	ELECT. SERVICE - WASH HTRS. *	20 KW
J	ELECT. SERVICE - RINSE HTRS. *	30 KW
K	ELECT. SERVICE - WASHER HTRS.	5 HP
L	ELECT. SERVICE - BOOSTER *	24/45 KW
M	ELECT. SERVICE - LIGHTS	120V

NOTES:

1. * * * = FOR ELECTRICALLY HEATED MACHINES ONLY.
2. • • • = HOT WATER TO BOOSTER 140° F STD / 110° F SPECIAL.
3. (2) 6" x 16" VENTS WITH ADJUSTABLE DAMPERS.

LEFT TO RIGHT FEED

CENTURY 14
 AUTOMATIC CONTINUOUS CONVEYOR TYPE DISHWASHING MACHINE
 Insinger
 Philadelphia, PA 19135
 (215) 624-4800
 FAX (215) 624-6966
 DRWN: MAM 7.28.93 SCALE
 REV: EMM 10.22.00 1/2" = 1'
 FILE: STD/CENT-LH CENT-LH J



ESSENTIAL SERIES

Project _____
Item _____
Quantity _____
CSI - 11400 _____
Approval _____
Date _____

DEFENDER Double Tank Rackless Conveyor Dishwasher

- Automatic conveyor, flight type two tank dishwasher with recirculating prewash and wash zones; and fresh water final rinse.
- 306 gallons hour final rinse consumption
- Capacity is 8,861 dishes per hour
- Conveyor speed of 7.1 feet per minute
- CrossFire® Wash System provides superior cleaning
- Error proof replacement with color-coded curtains
- Designed for left or right hand conveyor travel, as specified

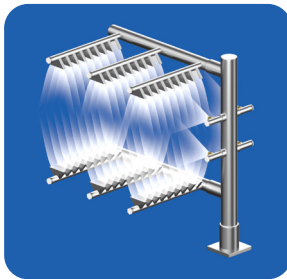

The patented CrossFire® Wash System power sprays water horizontally, as well as, from above and below, cleaning and sanitizing the dirtiest of ware.

STANDARD FEATURES

- CrossFire® Wash System
- SureFire® Start-Up & Check-Out Service
- Tank heat: 40.0 kW electric immersion heaters or steam injectors
- Capillary thermometers for pre-wash, wash, rinse and final rinse
- Final rinse pressure gauge
- Vacuum breaker on all incoming water lines
- Manifold clean-out brush
- Inspection and clean-out doors
- S/S frame, legs and feet
- S/S front enclosure panel
- Automatic tank fill
- Low water protection
- Detergent connection provision
- Top mounted NEMA 12 control panel
- Simplified scrap screen design
- Door safety switch
- Standard frame drip proof motors
- Single point electrical connection: motors, controls and heaters
- Polypropylene belt with removable rack sections
- Conveyor reversing switch
- Conveyor switch for de-liming
- Interior work lights
- Override switch for de-liming
- End caps/pipe plugs secured to prevent loss
- Color-coded curtains

OPTIONS

- Stainless steel steam coil tank heat
- Steam booster
- Electric booster
- Pressure reduction valve and line strainer
- Single point electrical connection: motors, controls and heaters
- S/S panels on all sides
- Security package
- Totally enclosed motors
- Insulated hood and door
- Stainless steel belt with removable rack sections





DEFENDER

Double Tank Rackless Conveyor Dishwasher

Capacity Per Hour	8861 dishes 600-1000 meals
Tank Capacity	20 gals. (pre-wash) 39 gals. (wash)
Motor Size	2 hp (pre-wash) 3 hp (wash) 1/2 hp (conveyor)
Electric Usage	40.0 kW wash tank *36.0 kW booster 40° rise *54.0 kW booster 70° rise
Steam Consumption at 20 psi min.	145 lbs./hour tank 109 lbs./hour booster 40° rise 190 lbs./hour booster 70° rise
Final Rinse Peak Flow at 20 psi min.	5.1 gallons/minute
Final Rinse Consumption at 20 psi min.	306 gallons/hour
Exhaust Hood Requirement	500 CFM Load 1000 CFM unload
Peak Rate Drain Flow	15 gallons/minute
Shipping Weight	2500 lbs.

Machine Electrical		
Motors, Controls Tank Heat	Steam	Electric
208/3/60	21.5	137.5
240/3/60	19.5	120.0
480/3/60	9.7	60.0
380/3/50	11.8	72.6

*Booster requires separate electrical connection

Contact Insinger Sales at 800-344-4802 for an installation drawing specific to your application. This drawing is available on the Insinger website at www.insingermachine.com

Note: Due to product improvement we reserve the right to change information and specifications without notice.

SPECIFICATIONS

CONSTRUCTION- Hood and tank all welded seamless construction using 16 gauge 18-8 type 304 S/S. S/S frame, legs and feet. All internal castings are non-corrosive nickel alloy, bronze or S/S.

DOORS- Three extra large die formed 18-8 type 304 S/S front inspection doors riding in all S/S channels. A triple ply leading edge on the door channels made of S/S with no plastic or nylon sleeves or liners used. Two intermediate S/S door-safety stops on each door.

CONVEYORS- Removable polypropylene or S/S rack section on S/S belt with polyethylene rollers. Conveyor drive system includes large speed reducer with cut gears operating in oil bath and frictionless, trouble-free overload release system. Conveyor transports dishware automatically through all washing and rinsing systems and is driven by an independent 1/2 hp motor. A trip bar at the end of the unload section stops the conveyor if any ware reaches the bar. A reversing switch is provided to assist in removing jams in the belt.

PUMPS- Centrifugal type "packless" pump with a brass petcock drains. Construction includes ceramic seal and a balanced cast impeller on a precision ground stainless steel shaft, extension or sleeve. All working parts mounted as an assembly and removable as a unit without disturbing pump housing. Two 2 hp motors wash and rinse and 1/2 hp pre-wash, all standard horizontal C-face frame, drip-proof, internally cooled with ball-bearing construction.

CONTROLS- Top mounted control cabinet, NEMA 12 rated with heat insulation provided between hood and control cabinet, housing motor controls and overload protection, transformer, contactors and all dishwasher integral controls. All controls safe low voltage 24 VAC.

ENERGY SAVER- Electric photo eye automatically operates the final rinse solenoid only when ware passes, saving water and energy. The photo eye also activates an adjustable timer control. If no ware passes during the set time, the machine shuts down.

SPRAY SYSTEM- Spray arms made of type 304 stainless steel pipe. Spray assemblies removable without the use of tools.

PRE-WASH- Upper and lower manifolds. One manifold above with 3 power pre-wash nozzles, one manifold below with 3 power pre-wash nozzles.

WASH- Upper and lower manifolds with the patented CrossFire® Wash System. Each manifold has 3 upper and 4 lower power wash arms designed with pressure action cleansing slots. The slots are precision milled for water control producing a fan spray. Wash arms are fillet welded to the S/S manifold. The CrossFire system provides 2 horizontally spraying high pressure nozzles.

RINSE- Upper and lower manifolds. Each manifold has 3 upper and 4 lower power rinse arms designed with pressure action fan spray reducing water consumption, maximizing heat retention.

FINAL RINSE- Eight nozzle assemblies above and four nozzles below threaded into S/S schedule 40 pipes. Nozzle assemblies produce a fan spray reducing water consumption, maximizing heat retention.

DRAIN- Drain valve externally controlled. Overflow assembly with skimmer cap is removable without the use of tools for drain line inspection. Heater is protected by low water level control.

INSTALLATION AND LAYOUT DETAIL

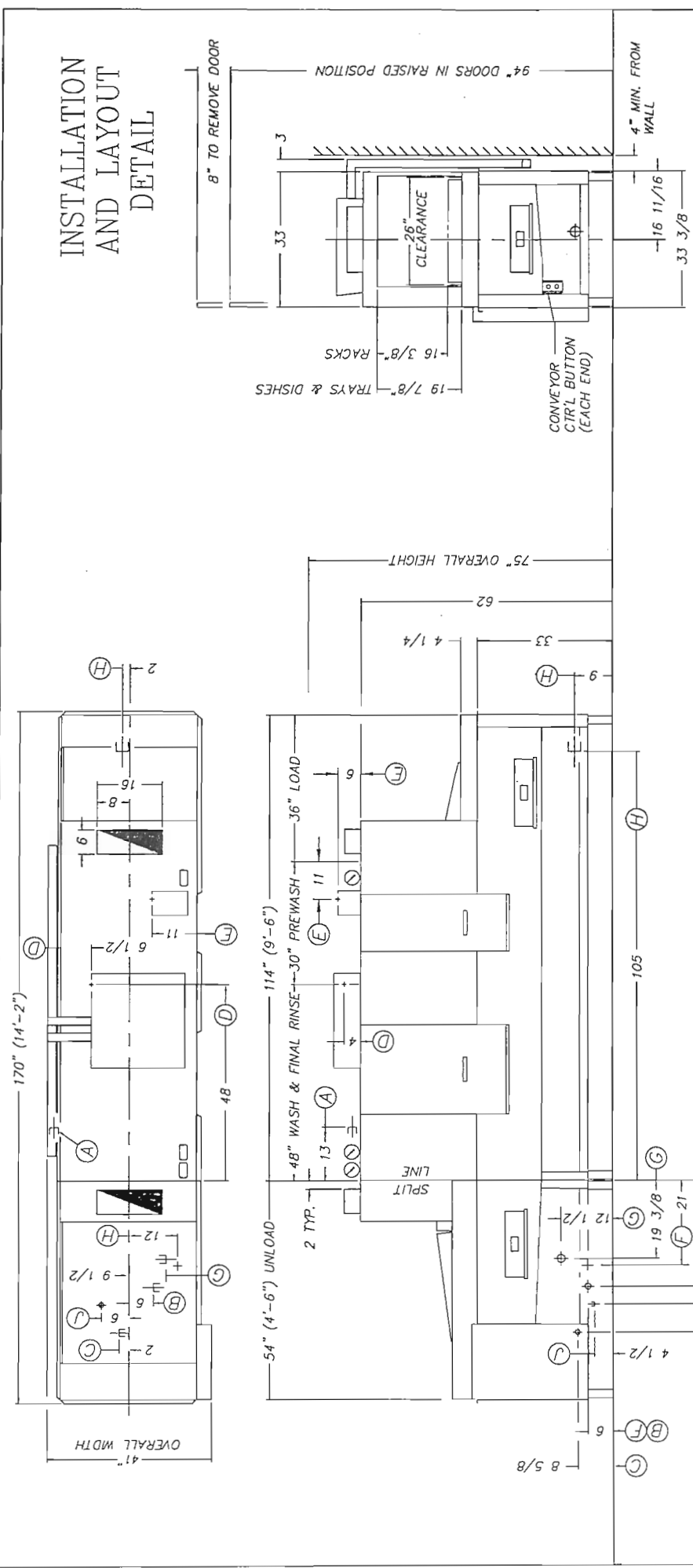

ECN #1669 3.26.99

RIGHT TO LEFT FEED

NOTES:

1. * * * HOT WATER TO BOOSTER 140' F STD/ 110' F SPECIAL
2. (2) 6" X 16" VENTS WITH ADJUSTABLE DAMPERS

FILE: STD/DEF14R

LTR	DESCRIPTION	SIZE
A	HOT WATER TO AUTO FILL-140' F	3/4 FIPS
B	HOT WATER TO ELECTRIC BOOSTER *	3/4 FIPS
C	HOT WATER TO STEAM BOOSTER *	3/4 FIPS
D	ELECTRICAL CONNECTION - COMMON	40 KW & 5 1/2 HP
E	ELECTRICAL CONNECTION - LIGHTS	120 V
F	ELECTRICAL CONNECTION - BOOSTER *	27/45 KW
G	STEAM TO BOOSTER AND TANKS	1 1/2 FIPS
H	DRAIN CONNECTION - COMMON	2" FIPS
J	CONDENSATE RETURN - COMMON	3/4 FIPS

INSTALLATION CONNECTIONS

DEFENDER 14

AUTOMATIC CONTINUOUS CONVEYOR TYPE DISHWASHING MACHINE

INSINGER

MACHINE COMPANY

6245 State Rd. Philadelphia PA 19135-2996
Tel. 215-624-4800 FAX: 215-624-6966

SCALE: 1/2" = 1'-0"

DRAWN: EMM	3.4.97	DWG. NO. DEFENDER A
APPROVED: EBA	3.4.97	

INSTALLATION AND LAYOUT DETAIL

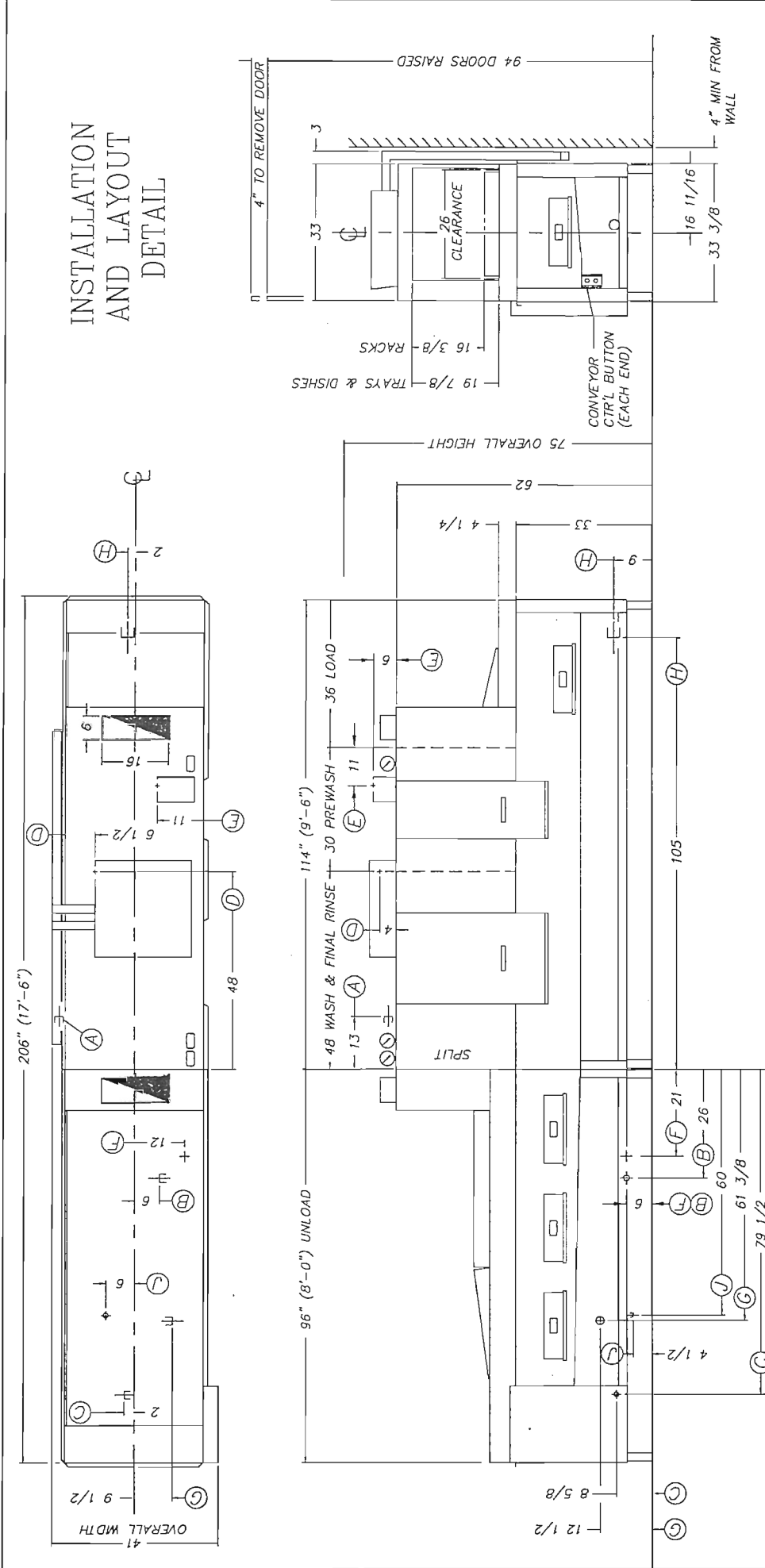

RIGHT TO LEFT FEED

- NOTES:
1. "•" HOT WATER TO BOOSTER 140° F STD./ 110° F SPECIAL
 2. (2) 6" x 16" VENTS WITH ADJUSTABLE DAMPERS

LTR	INSTALLATION CONNECTIONS DESCRIPTION	SIZE
A	HOT WATER TO AUTO FIL-140° F	3/4 FIPS
B	HOT WATER TO ELECTRIC BOOSTER *	3/4 FIPS
C	HOT WATER TO STEAM BOOSTER •	3/4 FIPS
D	ELECTRICAL CONNECTION - COMMON	40 KW & 5 1/2 HP
E	ELECTRICAL CONNECTION - LIGHTS	120 V
F	ELECTRICAL CONNECTION - BOOSTER *	27/45 KW
G	STEAM TO BOOSTER AND TANKS	1 1/2 FIPS
H	DRAIN CONNECTION - COMMON	2" FIPS
J	CONDENSATE RETURN - COMMON	3/4 FIPS

DEFENDER 17
 AUTOMATIC CONTINUOUS CONVEYOR TYPE DISHWASHING MACHINE

Philadelphia, PA 19135
 (215) 624-4800
 FAX (215) 624-6966

InSinger

DRWN: MFJ 6.24.96 SCALE
 REV: EMM 1.31.01 1/2" = 1'
 FILE: STD/DEF17R

REV C
 DEF17R

INSTALLATION AND LAYOUT DETAIL

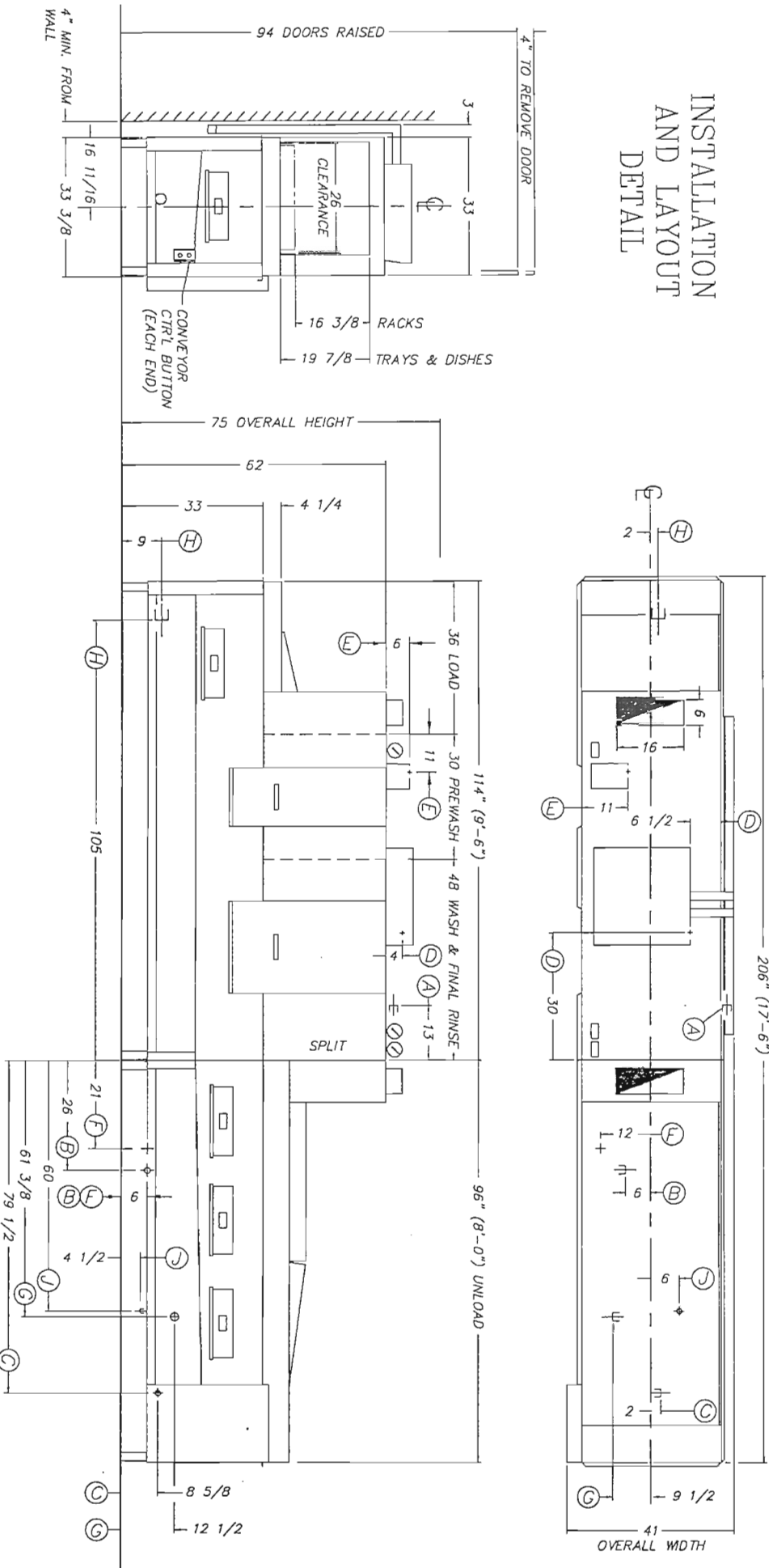

LTR	DESCRIPTION	SIZE
A	HOT WATER TO AUTO FIL-140' F	3/4 FPS
B	HOT WATER TO ELECTRIC BOOSTER	3/4 FPS
C	HOT WATER TO STEAM BOOSTER	3/4 FPS
D	ELECTRICAL CONNECTION - COMMON	40 KW & 5 1/2 HP
E	ELECTRICAL CONNECTION - LIGHTS	120 V
F	ELECTRICAL CONNECTION - BOOSTER	27/45 KW
G	STEAM TO BOOSTER AND TANKS	1 1/2 FPS
H	DRAIN CONNECTION - COMMON	2" FPS
J	CONDENSATE RETURN - COMMON	3/4 FPS

NOTES:

1. "●" HOT WATER TO BOOSTER 140' F STD / 110' F SPECIAL
2. (2) 6" X 16" VENTS WITH ADJUSTABLE DAMPERS

LEFT TO RIGHT FEED

DEFENDER 17
AUTOMATIC CONTINUOUS CONVEYOR TYPE DISHWASHING MACHINE

Insinger
Philadelphia, PA 19135
(215) 624-4800
FAX: (215) 624-6966

DRRM: MFJ 6.24.96 SCALE 1/2" = 1'
REV: EMM 1.31.01 DWG. NO. DEF17L C



INSINGER MACHINE COMPANY
LIMITED WARRANTY

Insinger Machine Company, Inc. (Insinger) hereby warrants to the original retail purchaser of this Insinger Machine Company, Inc. product, that if it is assembled, installed, and operated in accordance with the printed instructions accompanying it, that said Insinger product shall be free of defects in material and workmanship, for a period of one (1) year (12 months) after the date of installation or fifteen (15) months from the date of shipment from Insinger, whichever occurs first, provided the Surefire™ Start-up & Checkout is completed by an Insinger Authorized Service Agency. If the Surefire™ Start-up & Checkout service is not completed, the warranty will expire after one year from the date of shipment from the factory. The Surefire™ Start-up & Checkout service is included in the purchase price of your Insinger dishwasher. Insinger reserves the right to not have this service done. Insinger will not assume any responsibility of extra costs for installation in any areas where there are jurisdictional problems with local trades or unions.

Insinger may require reasonable proof of your date of purchase. Therefore, you should retain your copy of the invoice or shipping document.

This limited warranty shall be limited to the repair of parts which prove defective under normal use and service within the warranty period set forth above, and which on examination shall indicate, to Insinger's satisfaction, that the parts are defective. Insinger will repair the defective part/parts. All warranty work must be done during normal working hours, by either an Insinger Appointed Service Agency or an agency receiving prior authorization from Insinger. Defective parts become the property of Insinger. Parts replaced within the warranty period carry a warranty only until the end of the original limited warranty period. Replacement parts not supplied by Insinger will relieve Insinger of all future liability and responsibility.

This limited warranty does not cover: lighting of gas pilots or burners, cleaning of gas lines, replacement of fuses or resetting of overload breakers, adjustment of thermostats, adjustment of clutches, opening or closing of utility supply valves or switching of electrical supply, cleaning of valves, strainers, screens, nozzles, or spray pipes, performance of regular maintenance and cleaning as outlined in the TECH MANUAL, damages resulting from water conditions, accidents, alterations, improper



INSINGER LIMITED WARRANTY

Page 2

use, abuse, misapplication, tampering, improper installation or failure to follow maintenance and operation procedures, fire, flood, acts of God or improper maintenance or service, or for improper operation or failure to follow normal operating instructions (as set out in the TECH MANUAL) or failure as a result of the aforesated.

Examples of the aforementioned, but without limitations, are: damage to exterior or interior finish as a result of the above, use with utility service other than that designated on the rating plate, improper connection to utility service, inadequate or excessive water pressure, corrosion from chemicals dispensed in excess of recommended concentrations, failure of electrical components due to connection of chemical dispensing equipment installed by others, leaks or damage resulting from such leaks as made by installer including those at machine table connections or by connections of chemical dispensing equipment installed by others, failure to comply with local building codes, damage caused by labor dispute.

Insinger is not responsible nor liable for any conditions of erosion or corrosion caused by corrosive detergents, acids, lye or other chemicals used in the washing and/or cleaning process.

THIS WARRANTY IS THE ONLY WARRANTY APPLICABLE TO INSINGER PRODUCTS AND IS EXPRESSLY IN LIEU OF ALL OTHER EXPRESS OR IMPLIED WARRANTIES, INCLUDING ANY IMPLIED WARRANTY OF MERCHANTABILITY OR FITNESS FOR A PARTICULAR PURPOSE, AND ANY OTHER OBLIGATION ON THE PART OF INSINGER. THE REMEDY CONTAINED IN THIS WARRANTY IS THE SOLE REMEDY FOR ANY DEFECT FOUND TO EXIST IN AN INSINGER PRODUCT AND ALL OTHER DAMAGES ARE EXCLUDED, INCLUDING ANY LIABILITY FOR INCIDENTAL OR CONSEQUENTIAL DAMAGE.

Insinger does not authorize any person or company to assume for it any other obligation or liability in connection with this warranty or for any sale, installation, use, removal, return or replacement of its equipment; and no such representations are binding on Insinger.

THIS LIMITED WARRANTY SUPERSEDES ALL OTHER EXPRESS WARRANTIES, IMPLIED WARRANTIES OF MERCHANTABILITY AND FITNESS OR LIMITED WARRANTIES AS OF JANUARY 1, 1993.



PART 2
INSTALLATION and OPERATION
INSTRUCTIONS



**CENTURY 14 & DEFENDER SERIES
INSTALLATION INSTRUCTIONS
Part 2, Section A**

A.1 PLACEMENT

- A.1.1 Carefully uncrate machine.
- A.1.2 Bolt the two sections together.

Note

Use silicone caulking in addition to the gasketing material provided between the sections. This will minimize the possibility of leaks.

A.2 ELECTRICAL CONNECTIONS

- A.2.1 Connect electrical lines sized for the correct voltage, current and phase of the machine. These should agree with machine requirements indicated on the nameplate and labels in control panel.
 - A.2.1.1 There is an electrical connection required for the:
 1. Pumps and control circuit,
 2. Wash tank heaters (electric heat only) and,
 3. Rinse tank heaters (electric heat only - Century 14 only).
 - A.2.1.2 Machines provided with a single-point connection require one electrical connection in the control panel for all functions excluding the booster (not available on all models).

Caution

Connections must be made to a circuit breaker or fused disconnect as provided by the end-user and required by local codes. A laminated wiring diagram is inside the control panel

Fuse Sizing Chart

Model	208VAC/3Ø	230VAC/3Ø	380VAC/3Ø	460VAC/3Ø
Century 14				
Motor Circuit	25A	20A	15A	10A
Wash Heaters	70A	60A	40A	30A
Rinse Heaters	110A	90A	60A	45A
Defender				
Motor Circuit	25A	25A	15A	15A
Motor Circuit w/ BD (steam)	30A	30A	20A	15A
Wash Heaters	140A	120A	80A	60A
BD (electric)	90A	80A	50A	40A



CENTURY 14 & DEFENDER SERIES
INSTALLATION INSTRUCTIONS
Part 2, Section A

Caution

As with any 3 phase system, an electrician must check all motors for proper phasing, i.e., Pump motors must be running in direction indicated by arrow on housing.

- A.2.1.3 Electrical termination points are also required between each of the sections in the termination box located on the frame in the rear of the machine near where the sections meet.

A.3 MECHANICAL CONNECTIONS

- A.3.1 Connect 140DEGF and 180DEGF to pipestrings as tagged on the machines and noted on the installation drawing.
- A.3.2 If machine is provided with steam heat connect the steam lines and steam condensate lines as tagged and noted on installation drawings.
- A.3.3 Connect the drain lines.

Caution

Drain lines must be as specified on installation drawings. Drain line should be properly vented and should have fall of not less than $\frac{1}{4}$ " to the foot of proper flow. Some area plumbing codes require drains to flow into an open gap with an opening twice the diameter of the pipe. Check with your local plumbing codes for the type of drain connection required.

Caution

All lines must be flushed prior to use to remove debris.

Caution

Do not reduce the size of lines as specified in installation drawings. All lines are sized to facilitate necessary flows, pressures, etc.



CENTURY 14 & DEFENDER SERIES
INSTALLATION INSTRUCTIONS
Part 2, Section A

A.3.4 Adjust the compression spring located on the conveyor overload shutoff mechanism. This can be found on the unload end of the machine under the mechanism guard. There is a sticker marked with the factory test setting of the spring. Adjust to this point then run the conveyor full of ware. If the machine does not shut down the adjustment is set. If it does shut down adjust the spring tighter until the machine runs continuously.

A.4 HVAC

A.4.1 Ventilation system must be sized to provide adequate ventilation per machine specs. Refer to spec sheet.

A.4.2 Stainless steel, watertight ducting should be connected to the vent cowls on each end of the machine or an overhead venting system should be installed.

A.5 Chemicals

A.5.1 Upon completed installation of the dishwasher contact a local detergent/chemical supplier for the correct chemicals for your area.

A.5.2 Electrical connection points for the detergent dispenser and rinse injector are located inside the control panel. Refer to the wiring diagram for this machine for the proper connection points. Dispensers may be connected on either the primary voltage side of the machine or the 24VAC control voltage side.

Caution

When connecting on the 24VAC control voltage side of the transformer, total VA must not exceed 50VA.

A.5.3 The detergent density probe should be installed in the hole provided & labelled in the wash tank.

A.5.4 A switch on the control panel labelled "Energy Saver" is provided for de-liming the machine. When placed in the OFF position, this switch will defeat the machines energy saver function, allowing it to run continuously for de-liming. voltage side.



**CENTURY 14 & DEFENDER SERIES
OPERATION INSTRUCTIONS
Part 2, Section B**

Insinger dishwashers are user friendly, making them the easiest dishwashers on the market to operate and maintain.

By following the operation procedure and general cleaning procedures your Insinger dishwasher will give you years of trouble free service.

B.1 Operation Instructions

- B.1.1 Ensure drain overflow tube is in place Close all tank drain valves. One drain is provided for each tank of the dishmachine.
- B.1.2 Check for proper installation and cleanliness of all internal, removeable components such as suction strainers, scrap screens, and spray manifolds.
- B.1.3 Ensure all water, and steam lines are open. Ensure electrical circuits are on.
- B.1.4 Close machine doors.

Warning

An interlock is provided to shut the machine down if the doors are open, there the machine will not run if doors are opened. Machines provided with the optional Security Package do not have this feature.

- B.1.5 Move the power toggle switch to the "ON" position.
- B.1.6 The machine will automatically begin to fill.
- B.1.7 When the tanks are full the tank heat will operate automatically.

Caution

To ensure proper operation of the auto tank fill feature and the tank heaters, level float(s) located in each tank MUST be cleaned daily

- B.1.8 Depress the Green button on the control panel to operate the pumps.
- B.1.9 Located at the load and unload end of the machine is a start/stop station for operating the conveyor system. Depress the green button to start the conveyor.

Caution

An emergency stop bar is located at the end of the conveyor to shut the machine down. This will minimize ware breakage if the conveyor is not unloaded.



**CENTURY 14 & DEFENDER SERIES
OPERATION INSTRUCTIONS
Part 2, Section B**

B.1.10 A light labelled "Check Conveyor Belt" is provided on the control panel. When this light illuminates the machine will automatically shut down. Check the conveyor belt for jamming or ware caught in the belt.

Caution

Should the light illuminate after an initial check for jams, DO NOT continue to operate the machine. Immediately contact a qualified service technician. Refer to the Conveyor Overload Shutoff Mechanism Adjustment section in the Maintenance Section of this manual.

B.1.11 The system is now ready for operation. All ware should be properly scrapped.

B.1.12 Place dirty ware on the conveyor belt. The ware will pass through the various machine cycles. The final rinse is automatically started when ware passes the photo-eye located at the entrance of the machine.

Note

the photo-eye located at the entrance of the machine should be cleaned daily of lime scale build-up for proper operation of the energy saver feature and the final rinse.

B.1.13 Upon completion of ware cleaning depress the Red button located on the control panel to stop the pumps.

B.1.14 Depress the red button located at the stop/start station on either end of the machine to stop the conveyor.

B.1.15 Move the Power toggle switch to the "OFF" position.

Caution

Move the power toggle switch to the OFF position before draining the machine.

B.1.16 Refer to the cleaning procedures for proper clean-up of the dishmachine.

B.1.17 Report any unusual occurrences to qualified service personnel.



CENTURY 14 & DEFENDER SERIES
OPERATION INSTRUCTIONS
Part 2, Section B

- B.2 Operation Instructions for Optional Electric Blower Dryer**
- B.2.1 Move the power toggle switch to the "ON" position. The amber light will illuminate.
 - B.2.2 Depress the green button on the Electric Blower Dryer control panel to start the blower and heaters.

Caution

The green start button must be depressed for approximately 10 seconds.

- B.2.3 Depress the red button on the Electric Blower Dryer control panel to stop the blower and heaters.
- B.2.4 Move the power toggle switch to the "OFF" position to shut the Electric Blower Dryer down.



CENTURY 14 & DEFENDER SERIES
OPERATION INSTRUCTIONS
Part 2, Section B

The following cleaning procedures should be done daily, at the end of the shift.

B.3 Cleaning Procedures, Daily

- B.3.1 Remove all internal removeable parts including spray manifolds, scrap screens, drain overflow tubes, suction strainers and curtains.
- B.3.2 Remove the end caps from the spray manifolds and clean with the brush provided. Flush the manifolds.
- B.3.3 Flush scrap screens.
- B.3.4 Clean drain overflow tube.

Note
V-cup seal on the drain overflow tube may become gummed and not allow the overflow tube to seat properly. This will cause the drain to leak water. Remove any build-up on the v-seal. When the seal becomes worn, replace.

- B.3.5 Clean suction strainers of build-up.

Note
Improper cleaning of suction strainers will cause the pumps to cavitate. This will cause poor washing results.

- B.3.6 Clean tank level float(s).

Caution
Level floats must be cleaned daily. Build-up of scale or grease will cause faulty operation of the tank fill & heat system.

- B.3.7 Clean curtains. When curtains are beyond cleaning or torn they should be replaced.
- B.3.8 Final rinse nozzles should be cleaned of matter clogging the jet spray.
- B.3.9 Clean the photo-eye lenses with a damp, soft cloth.
- B.3.10 Doors should be left open to allow drying of interior surfaces.



PART 3
**MAINTENANCE and REPAIR
PROCEDURES**



CENTURY 14 & DEFENDER SERIES

Maintenance & Repair Procedures

Part 3, Section A

Following is a basic guide for the repair and replacement of common dishwasher parts.

Refer to the Basic Service Guide for troubleshooting tips.

A.1 MAINTENANCE

A.1.1 Daily - Refer to the operation and cleaning instructions provided in this manual for daily cleaning procedures.

A.1.2 Weekly

A.1.2.1 The entire machine should be wiped down using an industrial grade stainless steel cleaner.

A.1.2.2 Under the supervision of your detergent supplier the machine interior must be properly de-limed.

Caution

The water quality in some areas requires de-liming to be done more frequently. Contact your detergent supplier for recommended de-liming frequency.

A.1.3 Quarterly

A.1.3.1 Remove and clean the strainer screens on water and steam lines. If the screens cannot be cleaned, replace.

A.1.3.2 Inspect condition of solenoid valve seats and diaphragms. Replace where necessary.

A.1.3.3 Inspect drain O-Rings for leakage. Replace where necessary.

A.1.3.4 Adjust conveyor chain tension using adjustment bolts located on exit end of machine.

A.2 MAINTENANCE PROCEDURES

A.2.1 Solenoid Valve Disassembly

A.2.1.1 Disconnect power supply to machine. Turn off Water supply.

A.2.1.2 Remove cap on top of coil. Remove coil.

A.2.1.3 Remove 4 hex bolts and lift bonnet from valve body. Note positioning of spring and plunger.

A.2.1.4 Remove main piston.

A.2.1.5 Inspect for dirt, wear or lime build-up. Clean or replace as required.

A.2.1.6 Reassemble in reverse of disassembly.

CENTURY 14 & DEFENDER SERIES
Maintenance & Repair Procedures
Part 3, Section A

- A.2.2 Line Strainer Disassembly
 - A.2.2.1 Shut off water or steam supply.
 - A.2.2.2 Remove large hex nut on bottom of strainer body.
 - A.2.2.3 Remove strainer screen. Inspect and clean or replace as necessary.
 - A.2.2.4 Reassemble in reverse of disassembly. Water flow must be same direction as arrow on line strainer body. Use new gaskets to insure a tight seal.
- A.2.3 Pump Disassembly
 - A.2.3.1 Before disassembling pump ensure there are no obstructions in the pump intake. Remove and clean the suction strainer (inside tank).
 - A.2.3.2 IT IS NOT NECESSARY TO REMOVE THE PUMP HOUSING FROM THE MACHINE TO DISASSEMBLE THE PUMP.
 - A.2.3.3 Remove the pump motor and impeller adaptor by removing the 4 hex bolts attaching them to the pump housing.
 - A.2.3.4 Repair or replace the pump parts as required.
 - A.2.3.5 Reassemble in reverse of disassembly.
- A.2.4 Immersion Heater Replacement
 - A.2.4.1 The immersion heater MUST be completely submerged at all times. If this is not the case contact a qualified service technician. The heated surface should never be in contact with sludge.
 - A.2.4.2 Remove the housing covering the wiring terminations. Disconnect the immersion heater wires.
 - A.2.4.3 Remove the immersion heater by loosening and removing the large hex nut.
 - A.2.4.4 Install in reverse of removal.

Note

Use plumbers putty as gasketing around immersion heater.

- A.2.5 Tank Heat Temperature Adjustment
 - A.2.5.1 A temperature control board is provided in the control panel for easy adjustment of tank temperature. Though tank temperature is adjusted during the machines factory test it is sometimes necessary to re-adjust the temperature at start-up.
 - A.2.5.2 Locate the temperature control board (P/N DE9-96). Use the control panel layout drawing located in Section 3, Electrical Schematic and Replacement Parts.



CENTURY 14 & DEFENDER SERIES
Maintenance & Repair Procedures
Part 3, Section A

- A.2.5.3 Adjust the tank temperature to the desired temperature by turning the potentiometer located on the temperature control board. An arrow on the potentiometer indicates increase.
 - A.2.5.4 If the temperature does not change refer to section A.2.6, Troubleshooting Tank Temperatures.
- A.2.6 Troubleshooting Tank Temperatures
- A.2.6.1 Electric Heat
 - A.2.6.1.1 If temperature cannot be adjusted per section A.2.5 check the temperature control board P/N DE9-96 proper operation. If the temperature control board is faulty, replace.
 - A.2.6.1.2 Verify tank heat contactor is working correctly. If not, replace.
 - A.2.6.1.3 Verify all immersion heaters are working properly and not limed. If not, replace.
 - A.2.6.2 Steam Heat
 - A.2.6.2.1 See Section A.2.6.1.1.
 - A.2.6.2.2 Verify steam pressure per machine specifications.
 - A.2.6.2.3 Verify steam trap is not clogged. IF so, replace.
- A.2.7 Motor Overloads
- A.2.7.1 All motors used on Insinger Machines are provided with motor overloads. Motor overloads are adjusted when the machines are factory tested. Should it be necessary to adjust the motor overloads in the field first verify the motor current draw for the voltage the machine is using.
 - A.2.7.2 Using the Control Panel Component Layout Dwg. located in Section 3 to identify the overload adjust by turning the dial to the appropriate AMP draw.
- A.2.8 Level System
- A.2.8.1 The level control system consists of one level timer (P/N DE7-31) and one level float (P/N D35-60) per tank.
 - A.2.8.2 The system will not allow the tank heat to energize without water in the tank.
 - A.2.8.3 Should the tank heat energize without water in the tank troubleshoot the system to find the problem.

CENTURY 14 & DEFENDER SERIES
Maintenance & Repair Procedures
Part 3, Section A

Caution

Dirty level floats may cause the tank heat to energize with no water in the tanks.
LEVEL FLOATS MUST BE CLEANED DAILY.

A.2.9 Final Rinse Actuator

- A.2.9.1 The final rinse is actuated by the photo-eye emitter and receiver located at the entrance to the machine.
- A.2.9.2 When the beam is broken by a plate, etc., the final rinse timer is energized turning on the final rinse solenoid and allowing the water to flow. After one minute the timer will de-energize turning the solenoid off.
- A.2.9.3 The energy saver timer (P/N DE7-28) is reset to 0 at the same time the final rinse timer is energized. The energy saver timer is adjustable between 0-300SEC.

A.2.10 Conveyor Belt Adjustment

- A.2.10.1 The conveyor belt tension is adjustable by locating two adjustment bolts on the load side of the machine. The bolts can be moved in and out of the conveyor follower shaft therefore adjusting the belt tension.

A.2.11 Conveyor Overload Shut-off Mechanism (P/N 1100-289) Adjustment

- A.2.11.1 A clutchless overload is used to shut the machine completely down should a jam occur in the conveyor system. The jam may be caused by ware being caught, bent tracks or misalignment of the conveyor belt.
- A.2.11.2 Tension is held on the ATC Arm (P/N 1100-287) by a spring (P/N D-351). The ATC Arm keeps the switch (P/N D-2215A) engaged.
 - A.2.11.2.1 Should a jam occur the spring gives disengaging the ATC Arm from the switch. The "Check Conveyor Belt" light will illuminate and the machine will completely shut-down. Refer to the wiring diagram for the electrical controls.

CENTURY 14 & DEFENDER SERIES

Maintenance & Repair Procedures

Part 3, Section A

- A.2.11.3 Adjust the conveyor tension by loosening the adjusting nut and locknut.
- A.2.11.4 Turn the adjusting-nut to either compress or expand the spring. Compressing the spring will raise the required force to shut-down the machine, expanding the spring will lower the force.
- A.2.11.5 Maintain the adjustment by tightening the locknut to the adjustment nut.



BASIC SERVICE GUIDE

SYMPTOM	POSSIBLE CAUSE	Solution
1. Machine will not operate	<ul style="list-style-type: none"> a. No power b. Blown fuse or tripped breaker c. Motor overloads tripped 	<ul style="list-style-type: none"> a. Check power supply b. Replace fuse; reset breaker c. Reset overload
2. Tank will not hold water	<ul style="list-style-type: none"> a. Drain not closed b. Drain overflow not seated or installed c. Pump petcock opened d. Overflow v-seal dirt/worn 	<ul style="list-style-type: none"> a. Close drain b. Reseat or install drain overflow c. Close pump petcock d. Clean/replace v-seal
3. Tank fills beyond overflow	<ul style="list-style-type: none"> a. Obstruction in overflow tube or drain line 	<ul style="list-style-type: none"> a. Remove obstruction
4. Water leaks around door	<ul style="list-style-type: none"> a. Doors not seating b. Clogged spray pipe 	<ul style="list-style-type: none"> a. Reseat doors b. Clean spray pipe with brush provided
5. Weak or ineffective spray	<ul style="list-style-type: none"> a. Clogged spray pipe b. Manifolds not installed properly c. Obstruction in pump d. Pump rotation reversed e. Suction strainer clogged 	<ul style="list-style-type: none"> a. Clean spray pipe with brush pipe b. Ensure proper placement of upper and lower pipes c. Clear obstruction through pump inspection plate d. Arrow on pump housing indicates direction, correct electrically e. Clean suction strainer

BASIC SERVICE GUIDE

SYMPTOM	POSSIBLE CAUSE	Solution
6. Weak or ineffective final rinse spray	<ul style="list-style-type: none"> a. Lime deposits in spray nozzles b. Low water pressure c. Clogged line strainer d. Closed water supply valve 	<ul style="list-style-type: none"> a. Clean or replace nozzles b. Adjust to 20PSI c. Remove line strainer and clean d. Open ball valve
7. Water hammer	<ul style="list-style-type: none"> a. Excessive water line pressure 	<ul style="list-style-type: none"> a. Install water hammer valve
8. Machine vibrates or is noisy	<ul style="list-style-type: none"> a. Pump rotation reversed 	<ul style="list-style-type: none"> a. Arrow on pump housing indicates direction, correct electrically
9. Final rinse will not shut off	<ul style="list-style-type: none"> a. Final rinse solenoid valve clogged b. Diaphragm worn c. Solenoid valve still powered-up 	<ul style="list-style-type: none"> a. Disassemble valve and clean internal parts of scale or replace b. Replace with solenoid valve repair kit c. Check final rinse actuating circuit for proper operation

BASIC SERVICE GUIDE

SYMPTOM	POSSIBLE CAUSE	Solution
10. Tank not filling/tank heat coming on with no water in tank	<ul style="list-style-type: none"> a. Level float dirty b. Level control system not working 	<ul style="list-style-type: none"> a. Clean level float b. Troubleshoot level control circuit
11. Tank temperature too low/high	<ul style="list-style-type: none"> a. Thermostat not adjusted b. Heat circuitry not working c. Electric heat - power turned off d. Electric heat - immersion heaters limed e. Steam heat - steam turned off f. Steam heat - not enough steam g. Steam heat - condensate traps clogged h. Gas heat - gas turned off i. Gas heat - pilot not lit (if provided) 	<ul style="list-style-type: none"> a. Adjust thermostat b. Troubleshoot circuitry c. check circuit breakers d. De-lime machine e. Turn steam on f. Adjust steam pressure per machine spec's g. Clean or replace condensate traps h. Turn on gas i. Re-light pilot



PART 4

**ELECTRICAL SCHEMATICS and
ELECTRICAL REPLACEMENT PARTS**

FOR CENTURY 14

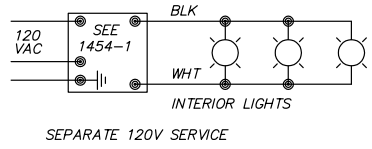
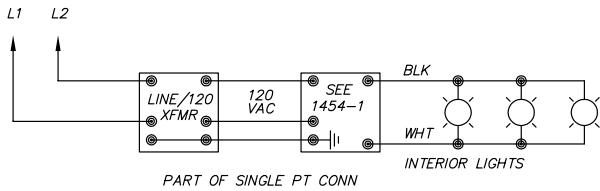
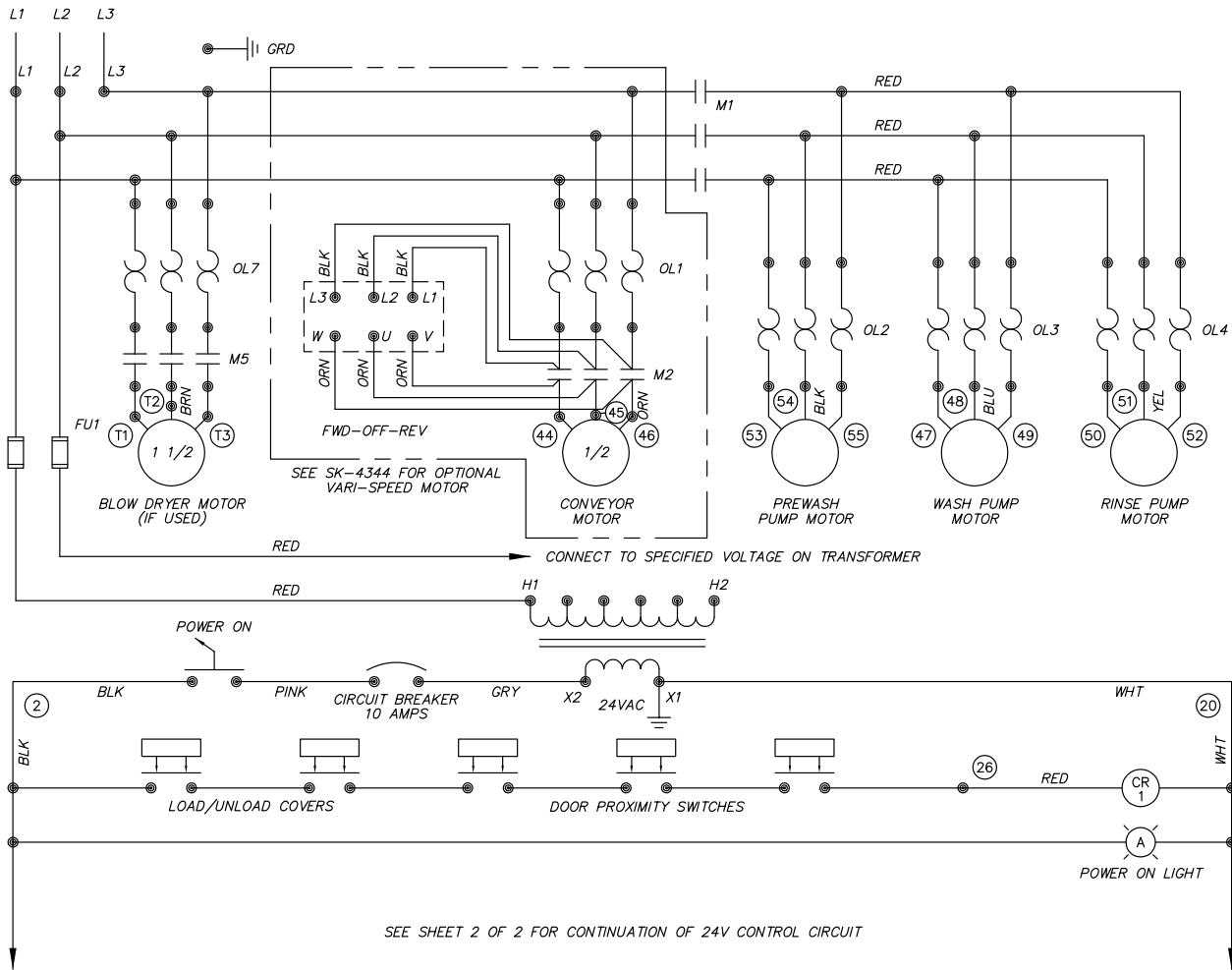

U	-	10.15.24	TITLE	CLIPPER/MASTER/CENTURY	DWG. NO.	
T	1927	3.25.02		STEAM HEAT	WFLT010	
S	1907	11.16.01				
REV	ECN NO	DATE			DRWN/DATE	
FILE:	WIRE\WFLT010				Philadelphia, PA 19135 (215) 624-4800 FAX (215) 624-6966	RAF

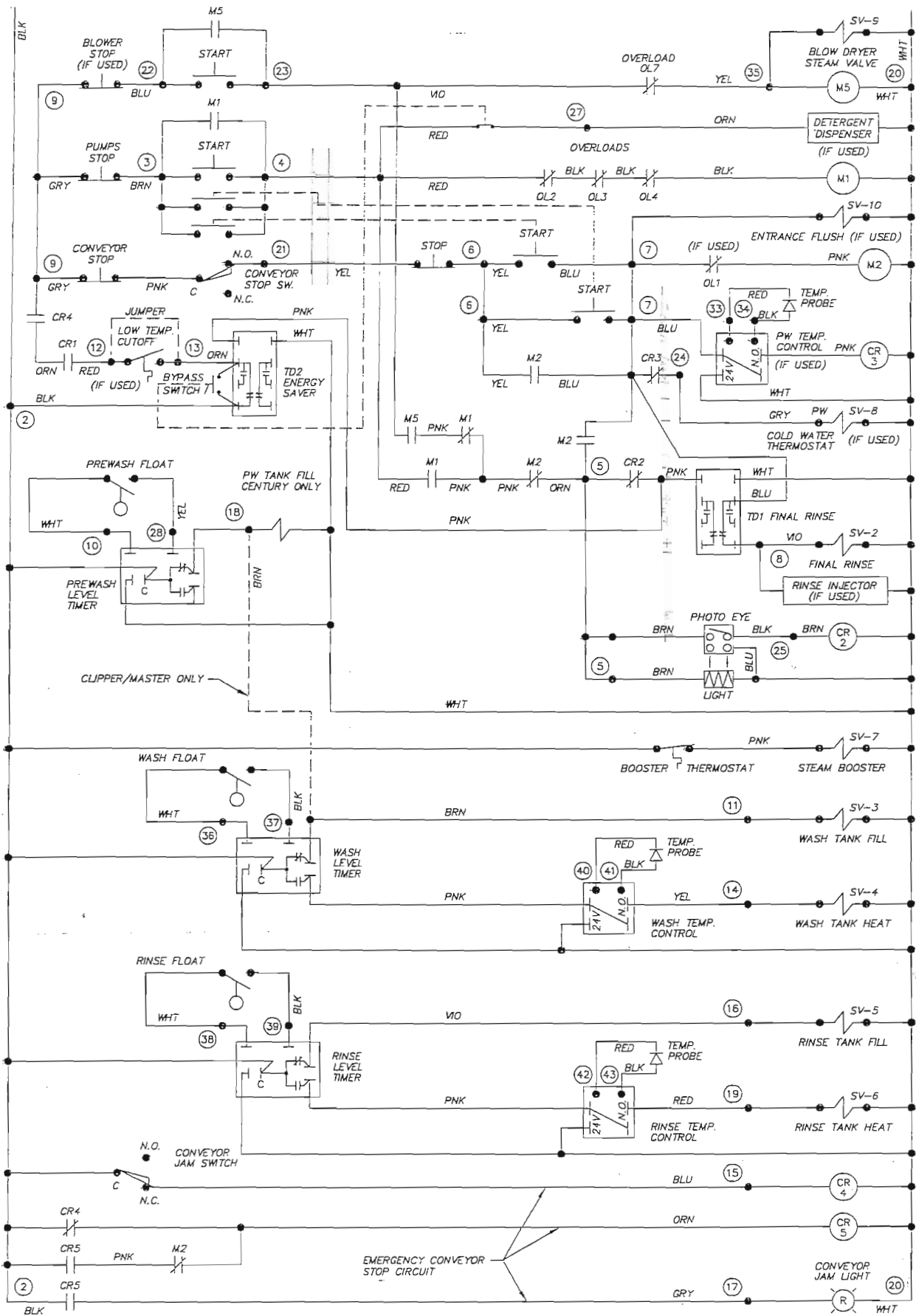

			TITLE	CLIPPER/MASTER/CENTURY STEAM HEAT	DWG. NO.	WFLT010
T	1927	3.25.02				
S	1907	11.16.01				
REV	ECN NO	DATE				
FILE: WIRE\WFLT010					Philadelphia, PA 19135 (215) 624-4800	DRWN/DATE RAF 05.01.95
			FAX (215) 624-6966			

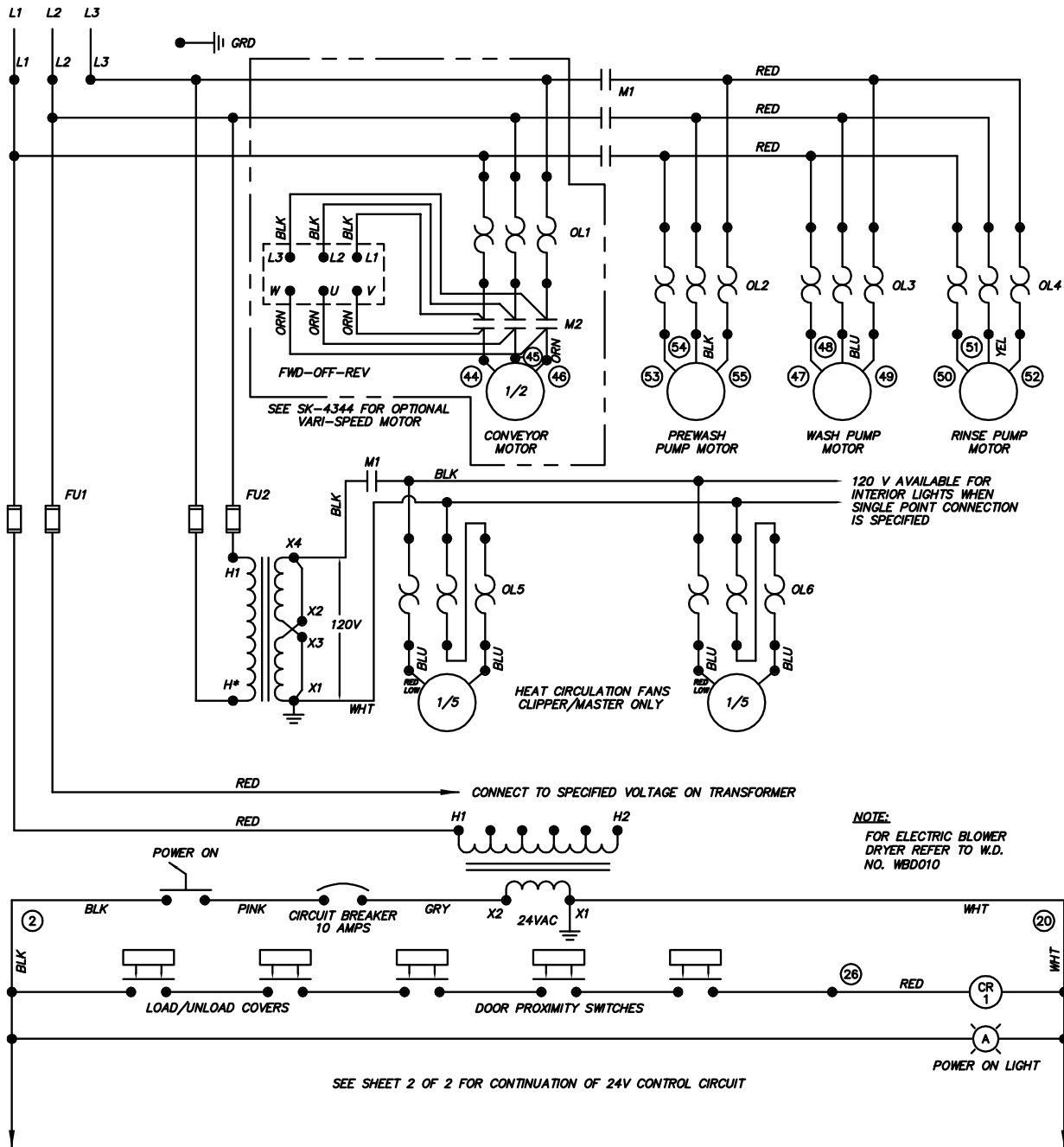

NOTE:
FOR ELECTRIC BLOWER DRYER REFER TO W.D. NO. WBD010

SEE SHEET 2 OF 2 FOR CONTINUATION OF 24V CONTROL CIRCUIT

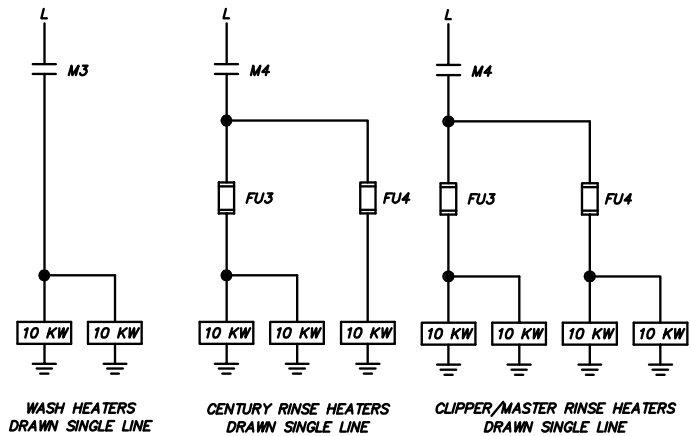

WASH HEATERS DRAWN SINGLE LINE

CENTURY RINSE HEATERS DRAWN SINGLE LINE

CLIPPER/MASTER RINSE HEATERS DRAWN SINGLE LINE

NOTE:
1. THREE SEPARATE ELECTRICAL SERVICES ARE NECESSARY:
1- MOTORS/CONTROLS
2- WASH HEATERS
3- RINSE HEATERS

V	-	10.15.24	TITLE	CLIPPER/MASTER/CENTURY	DWG. NO.	WFLT020
U	1927	3.25.02		ELECTRIC HEAT		
T	1717	11.18.99				
REV	ECN NO	DATE				
FILE:	WIRE\WFLT020				Philadelphia, PA 19135	DRWN/DATE
					(215) 624-4800	RAF
					FAX (215) 624-6966	05.06.95

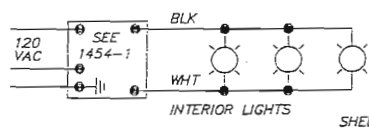
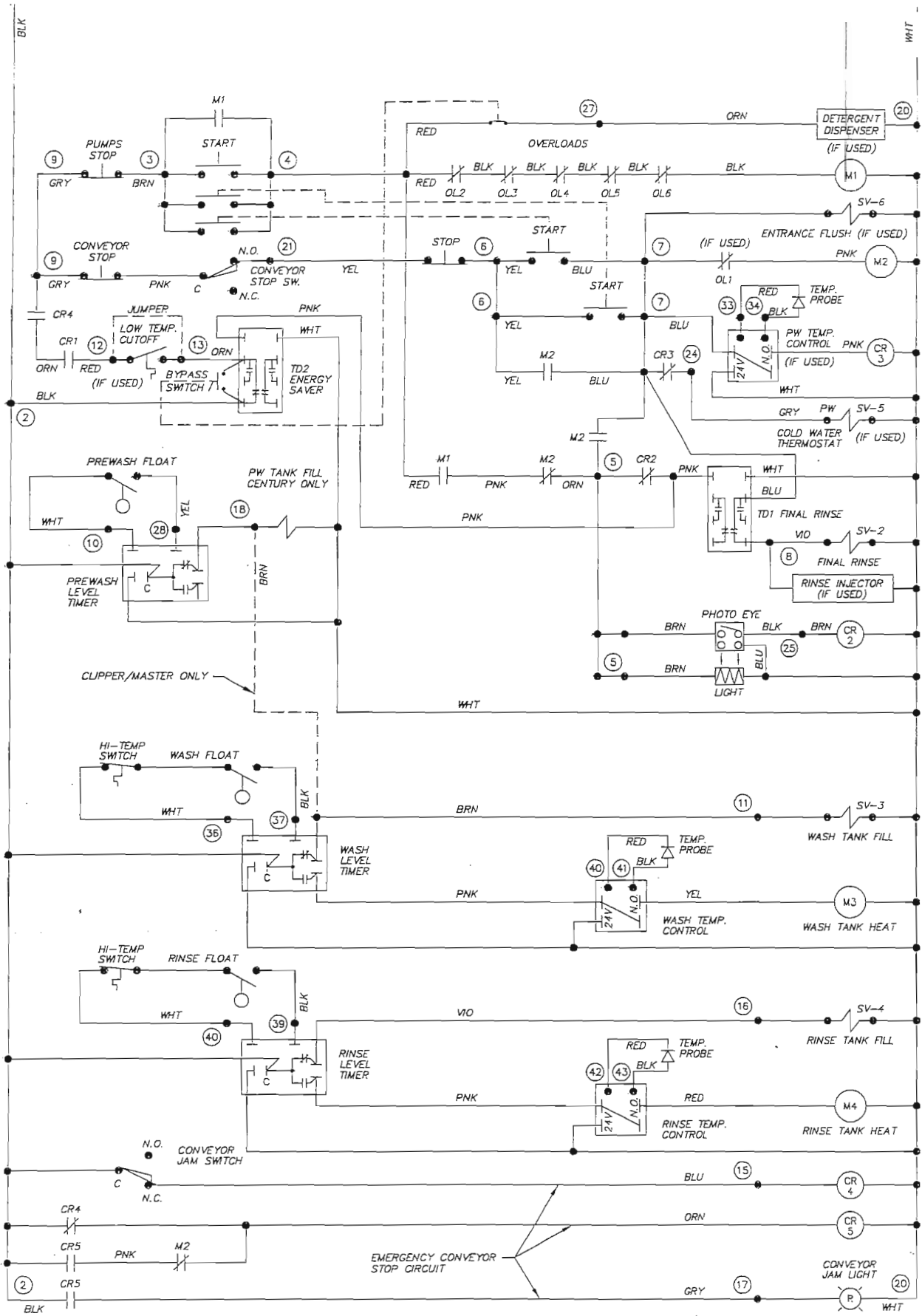

SHEET 2 OF 2

U	1927	3.25.02	TITLE	CLIPPER/MASTER/CENTURY	DWG. NO.	WFLT020
T	1717	11.18.99		ELECTRIC HEAT		
S	1661	3.11.99				
REV	ECN NO	DATE	Insinger		Philadelphia, PA 19135	DRWN/DATE
FILE:	WIRE\WFLT020		Insinger		(215) 624-4800	RAF
					FAX (215) 624-6966	05.06.95

ITEM	DESCRIPTION	PART NO.	QTY
1	COMPONENT MTG PLATE (NEMA 12 BOX)	1282-30	1
2	TRANSFORMER (250 VA, 24 VAC)	DE6-25	1
3	FUSE BLOCK KIT (250 VA XFMR)	DE9-165	1
4	FUSE (250 VA TRANSFORMER PRIMARY)	DE9-165	2
	460 V	FNQ-R-1.8	
	380 V	FNQ-R-2	
	220 - 230 V	FNQ-R-3.5	
	208 V	FNQ-R-4	
5	OVERLOAD RELAY (1/2 HP CENTURY PRE-WASH PUMP, ALL 1/2 HP CONV DRIVES)	DE2-50	AR
	460/3/60	1-1.6 A	
	380/3/50	1-1.6 A	
	230/3/60	1.6-2.5 A	
	208/3/60	1.6-2.5 A	
6	OVERLOAD RELAY (1-1/2 HP CLIPPER PREWASH PUMP AND 1-1/2 HP STEAM DRYER MOTOR)	DE2-52	AR
	460/3/60	1.6-2.5 A	
	380/3/50	2.5-4 A	
	230/3/60	4-6 A	
	208/3/60	4-6 A	
7	OVERLOAD RELAY (2 HP CENTURY & CLIPPER WASH/RINSE AND 2 HP MASTER PW PUMPS)	DE2-53	AR
	460/3/60	2.5-4 A	
	380/3/50	2.5-4 A	
	230/3/60	5.5-8 A	
	208/3/60	5.5-8 A	
8	OVERLOAD RELAY (3 HP MASTER WASH & RINSE PUMPS)	DE2-55	2
	460/3/60	4-6 A	
	380/3/50	4-6 A	
	230/3/60	7-10 A	
	208/3/60	7-10 A	
9	OVERLOAD RELAY (1/5 HP HEAT FAN)	DE2-56	2
	120/1/60	2.5-4	

SHEET 1 OF 2

TITLE: CLIPPER/MASTER/CENTURY CONTROL PANEL LAYOUT

Philadelphia, PA 19135 DRWN/DATE
 (215) 624-4800 MFJ
 FAX (215) 624-6966
 FILE: SKETCH1 SK-3623 05.20.95

INSINGER

SCALE: 1/4 DWG. NO.
 J 1945 7.17.02
 H 1857 2.15.01
 REV EGN NO. DATE

REV: SKETCH1 SK-3623

16 GA SECURITY PLATE (OVER LATCH)
 NEMA 4X SEC PKG ONLY

Ø1/4 (2)
 #10-32 STUD &
 SEAL NUT

NEMA 12 PLATE (SHOWN): 21W X 22D
 NEMA 4X PLATE: 22 3/16 SQ

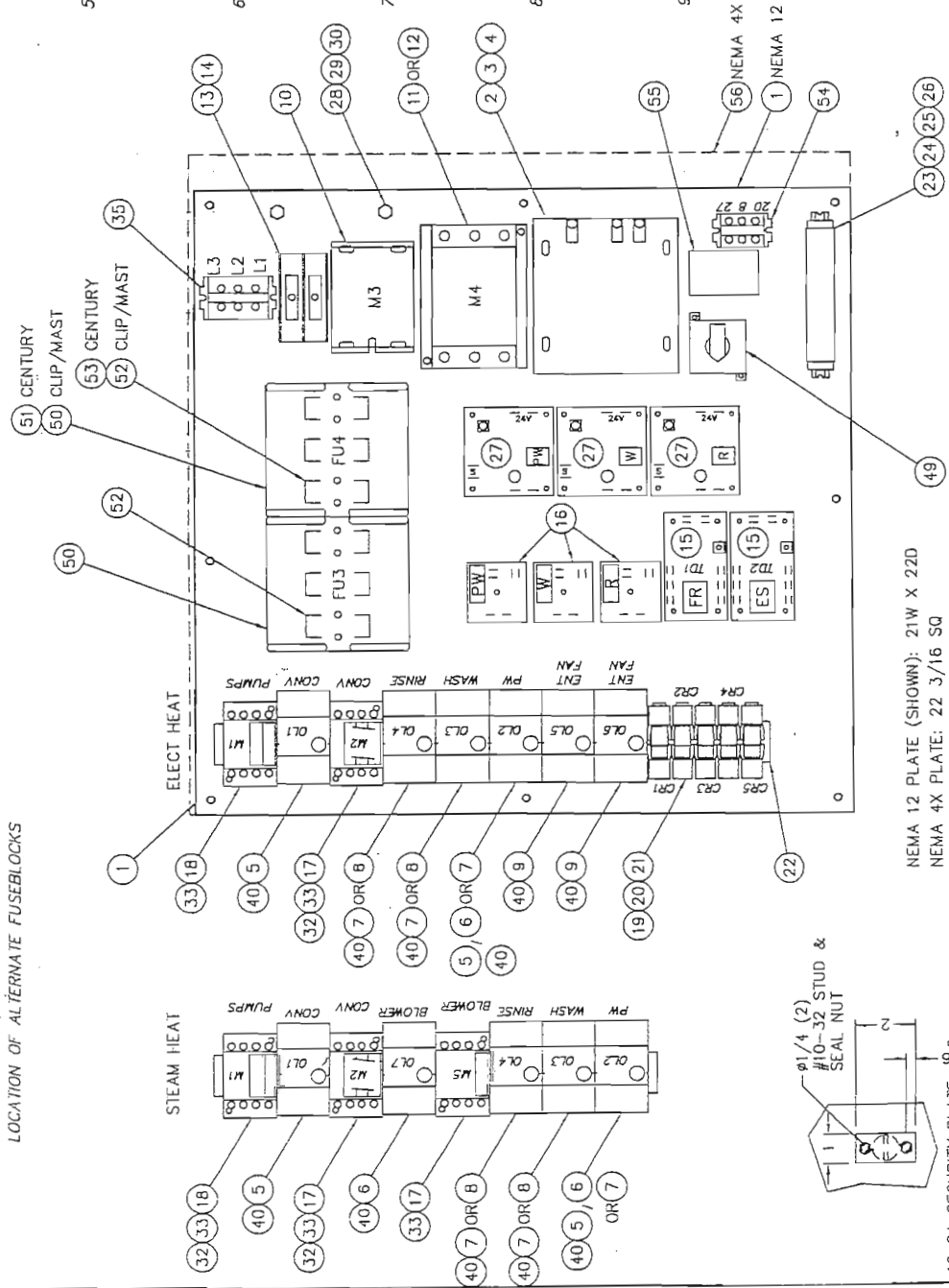
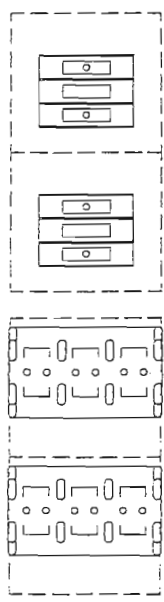

ITEM	DESCRIPTION	PART NO.	QTY	ITEM	DESCRIPTION	PART NO.	QTY
10	CONTACTOR (20 KW ELECT WASH TANK HEAT ONLY)	DE1-109	1	18	CONTACTOR (PUMPS)	DE1-93	1
	460/3/60	30 A RES			CENTURY	DE1-56AE	
	380/3/50	50 A RES			CLIP & MAST (380 - 460 V) SP17	DE1-55AE	
	230/3/60	65 A RES			CLIP & MAST (208 - 230 V) SP27		
	208/3/60	65 A RES		19	RELAY BASE	DE2-37	AR
11	CONTACTOR (30 KW ELECT RINSE TANK HEAT ONLY)	DE1-110	1	20	RELAY	DE2-38	AR
	460/3/60	50 A RES		21	RELAY HOLD DOWN SPRING	DE3-43	AR
	380/3/50	65 A RES		22	DIN RAIL (35 mm)	DE9-216	1
	230/3/60	SP-47		23	DIN RAIL (15 mm)	DE3-42	1
	208/3/60	SP-57		24	TERMINAL SECTION	DE3-39	AR
12	CONTACTOR (40 KW ELECT RINSE TANK HEAT ONLY)	DE1-111	1	25	TERMINAL END COVER PLATE	DE3-40	1
	460/3/60	65 A RES		26	TERMINAL END CLAMP	DE3-41	2
	380/3/50	SP-47		27	TEMPERATURE CONTROL BOARD	DE9-251	AR
	230/3/60	SP-77		28	GROUNDING STUD	D309C-GC-4G	2
	208/3/60	SP-77		29	LOCKWASHER, 1/4"	D313C-G5	2
13	FUSE BLOCK, 2 POLE (FMR PRIMARY)	DE9-185	1	30	HEX NUT, 1/4-20	D312C-GC-2	2
	460 V	FNO-R-4		31	CONTACT BLOCK, NC	DE5-42AE	1
	380 V	FNO-R-5		32	AUX CONTACT NC	DE1-61AE	AR
	230 V	FNO-R-7.5		33	AUX CONTACT NO	DE1-62AE	AR
	208 V	FNO-R-8		34	CIRCUIT BREAKER (10A)	DE9-106	1
14	FUSE (1000 VA TRANSFORMER PRIMARY)	DE9-175	2	35	TERMINAL BLOCK ASSY	DE3-3	1
	460 V	FNO-R-4		36	SELECTOR SWITCH ASSY	DE8-54	2
	380 V	FNO-R-5		37	CONTACT BLOCK, NO	DE5-41AE	1
	230 V	FNO-R-7.5		38	PILOT LIGHT ASSY - YELLOW	DE8-53	1
	208 V	FNO-R-8					
15	TIMER (ENERGY SAVER & FINAL RINSE)	DE9-178	2				
16	TIMER (LIQUID LEVEL)	DE7-28	AR				
17	CONTACTOR (CONV & DRYER BLOWER) SP4	DE1-93	AR				

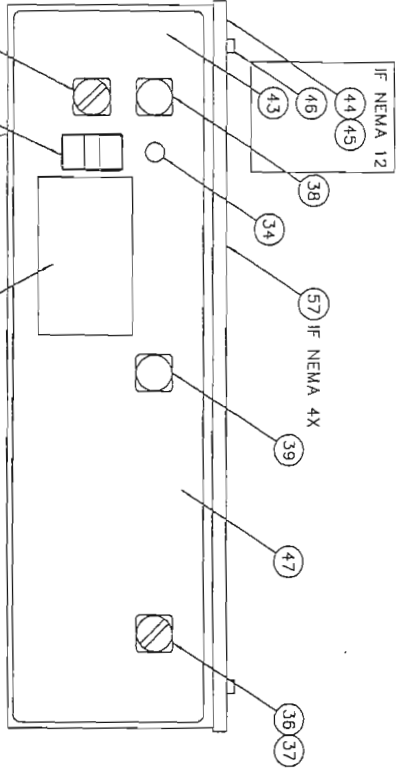

NOT SHOWN
ELECTRIC IMMERSION HEATER (10 KW)
440-480 V, 3 PH
380 V, 3 PH
220-240 V, 3 PH
208V, 3PH
TRANSFORMER (DRY) FOR HEAT FANS
1000 VA
1000 VA (208 & 380 V ONLY)
REMOTE START/STOP PUSHBUTTON STA
TEMPERATURE SENSOR

ITEM	DESCRIPTION	PART NO.	QTY
39	PILOT LIGHT ASSY - RED	DE8-52	1
40	OVERLOAD BASE	DE2-60	AR
41	PUSHBUTTON ASSY, START-STOP	DE5-3250	1
42	CONTACT BLK, NO/NC	DE5-4650	1
43	CONTROL BOX, NEMA 12	1442-32	1
44	CONTROL BOX COVER, NEMA 12	1442-32	1
45	GASKET, NEMA 12 BOX	9007-001	1
46	NUT, NEMA 12 BOX	D312C-EF-5	4
47	DECAL	SK-3799	1
48	DATA DECAL	SK-3715	1
49	SMITCH (FWD - OFF - REV)	DE8-56	1
50	FUSEBLOCK		AR
	460 V	DE9-186	
	380 & 230 V	DE9-212	
	208 V	DE9-213	
51	FUSEBLOCK (CENTURY ONLY)		1
	460, 380, & 230 V	DE9-186	
	208 V	DE9-212	
52	FUSE		AR
	460 V	KTK-R-30	
	380 V	JUS-40	
	230 V	JUS-60	
	208 V	JUN-70	
53	FUSE (CENTURY ONLY)		3
	460 V	KTK-R-15	
	380 V	KTK-R-20	
	230 V	KTK-R-30	
	208 V	JUS-35	
54	TERMINAL BLOCK ASSY	DE3-9	1
55	CAUTION LABEL	SK-3451	1
56	COMPONENT MTC PLATE, NEMA 4X BOX	SK-4446	1
57	CONTROL BOX (24 X 24 X 8), NEMA 4X	DE9-249	1



Insinger
 Philadelphia, PA 19135
 (215) 624-4800
 FAX (215) 624-6966
 FILE: SKETCH/SK-3623
 SCALE 1/4
 DWG. NO. SK-3623
 DRWN/DATE
 M/FJ 05.20.95
 SHEET 2 OF 2

REV	ECN NO	DATE
J	1945	7.17.02
H	1857	2.15.01

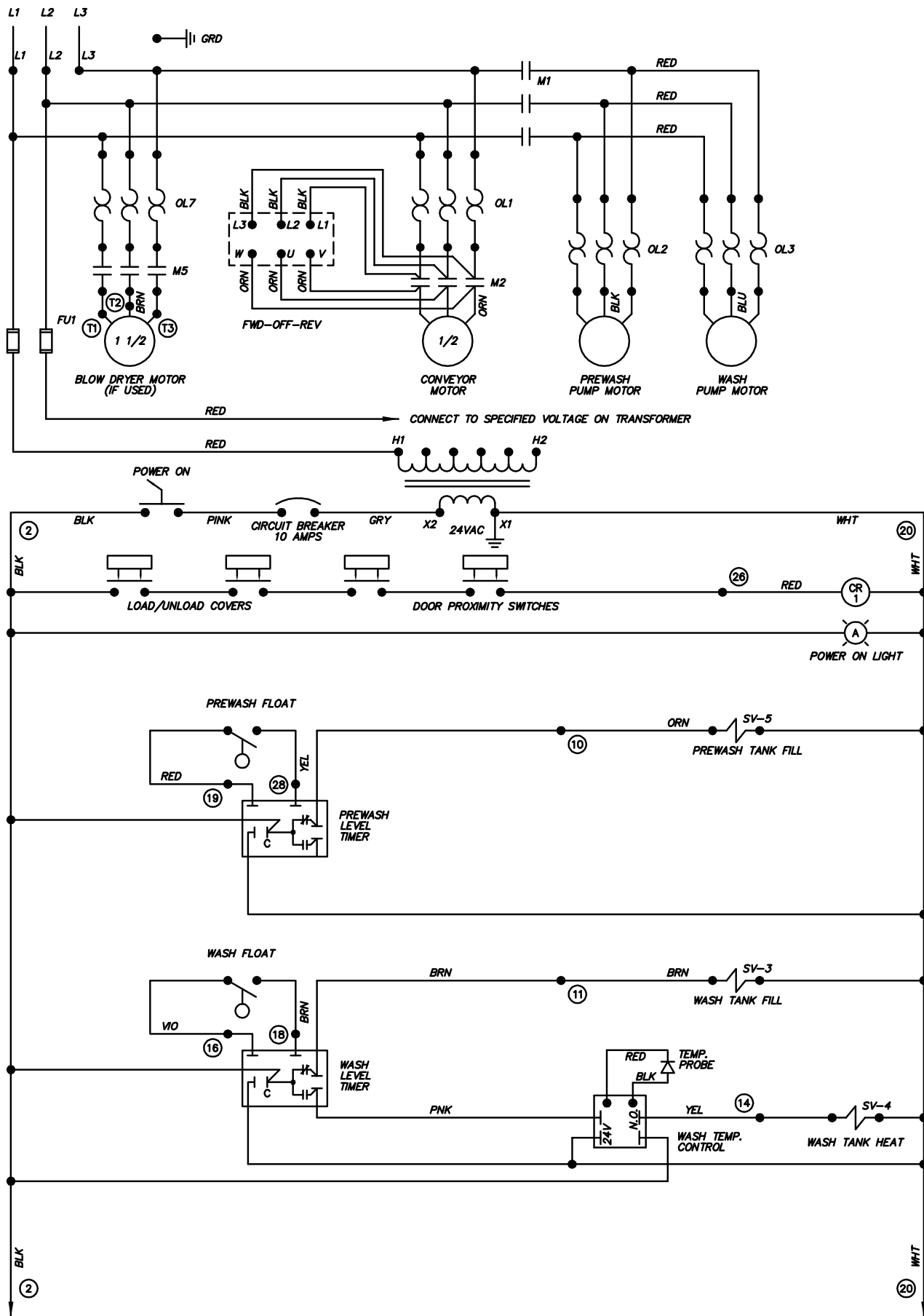

PART 4

**ELECTRICAL SCHEMATICS and
ELECTRICAL REPLACEMENT PARTS
FOR DEFENDER SERIES**



SEE SHEET 2 OF 2 FOR CONTINUATION OF 24V CONTROL CIRCUIT

E	-	10.15.24	TITLE	DEFENDER	DWG. NO.
D	1927	3.25.02		STEAM HEAT	WDEF010
C	1907	11.16.01			
REV	ECN NO	DATE	Philadelphia, PA 19135 (215) 624-4800 FAX (215) 624-6966		DRWN/DATE
					MFJ
FILE: WIRE\WDEF010					

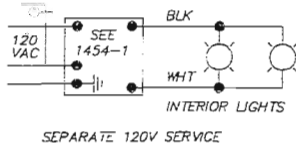
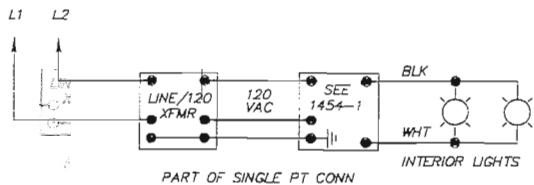
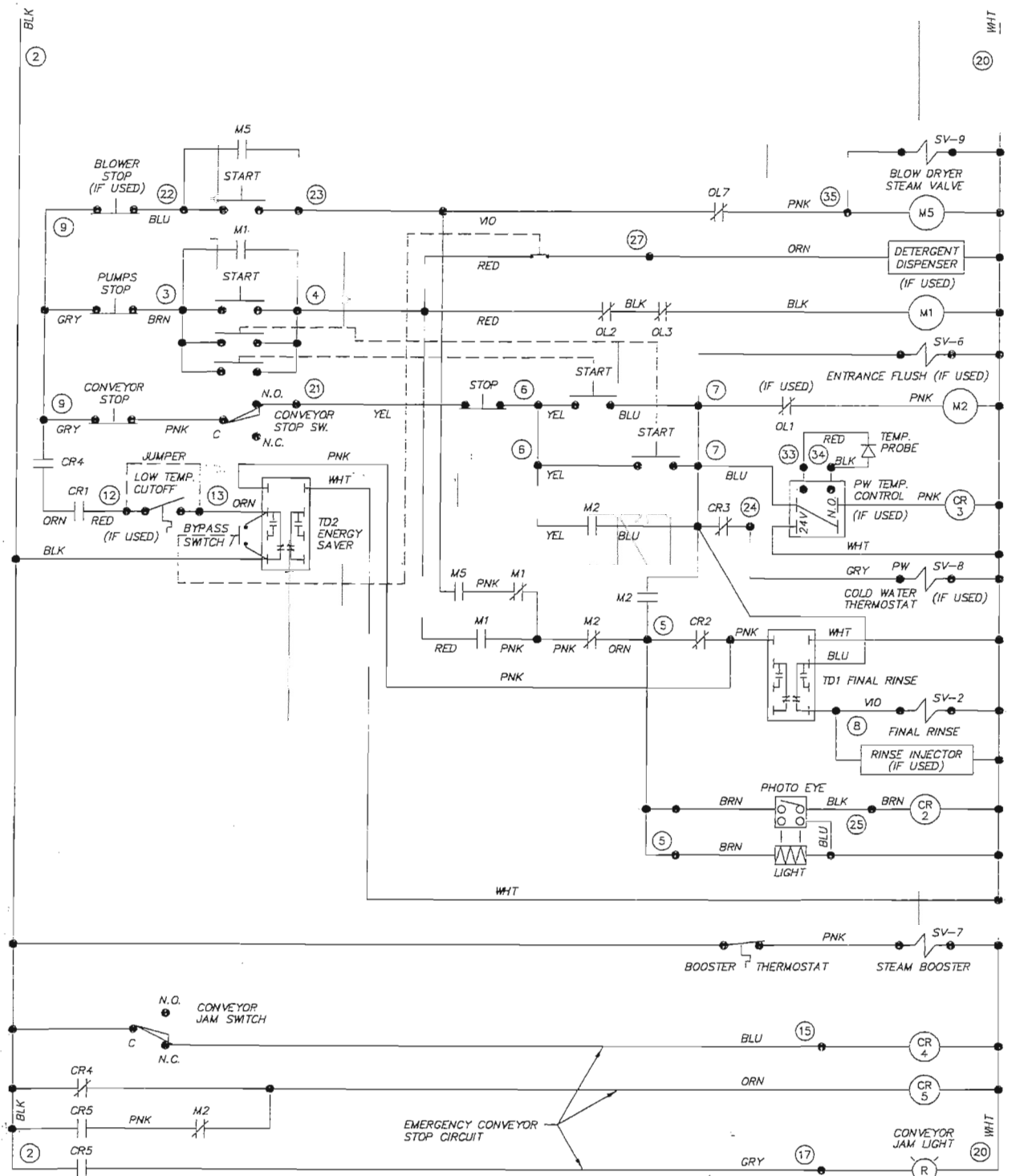

SHEET 2 OF 2

D.	1927	3.25.02	TITLE	DEFENDER STEAM HEAT	DWG. NO.	WDEF010
C	1907	11.16.01				
B	1583	12.1.97				
REV	ECN NO	DATE			PHILADELPHIA, PA 19135	DRWN/DATE
					(215) 624-4800	MFJ
FILE: WIRE\WDEF010					FAX (215) 624-6866	12.23.96

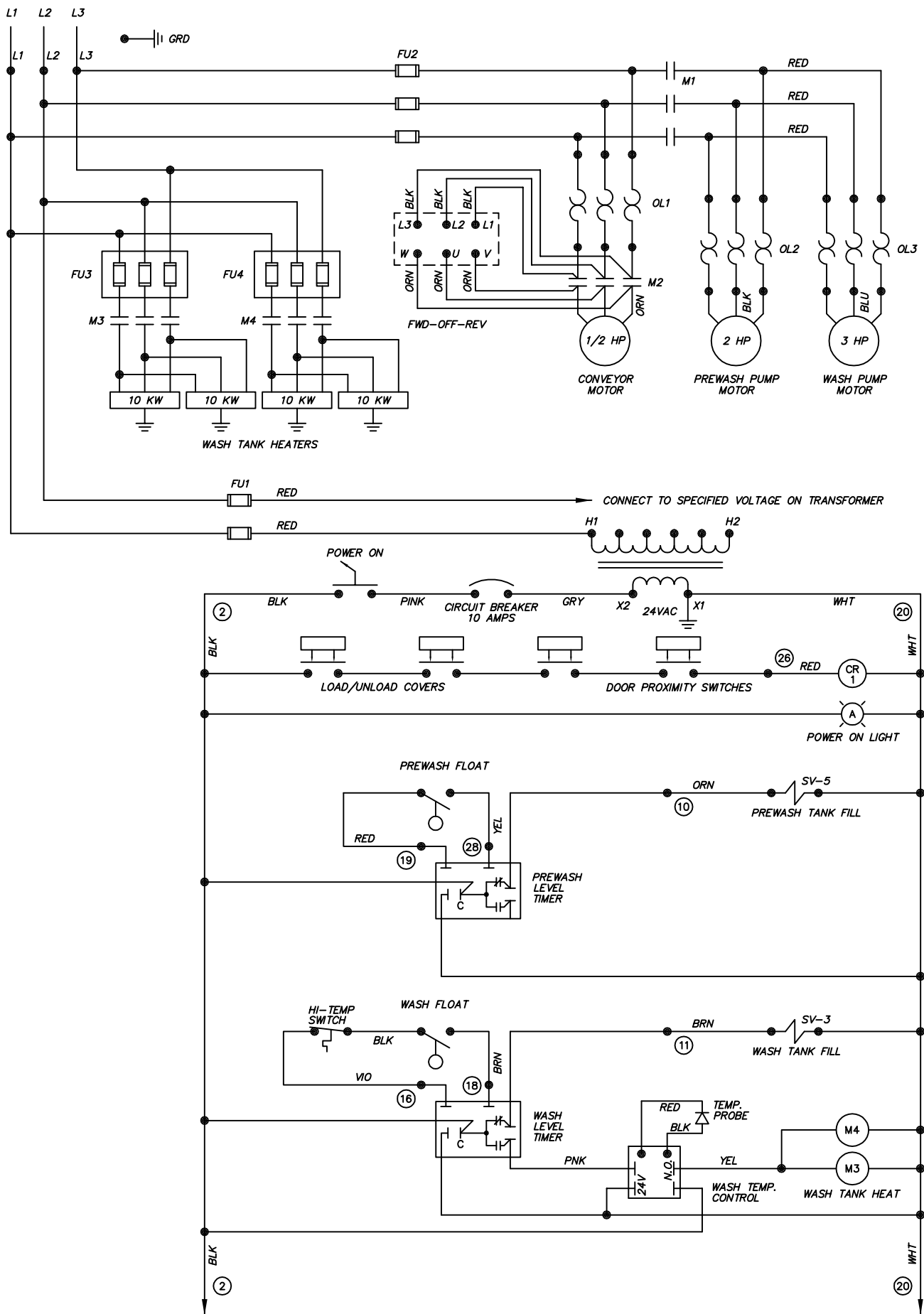

SEE SHEET 2 OF 2 FOR CONTINUATION OF 24V CONTROL CIRCUIT

D	-	10.15.24	TITLE	DEFENDER ELECTRIC HEAT	DWG. NO.	WDEF020
C	1927	3.25.02				
B	1583	12.1.97				
REV	ECN NO	DATE				
FILE: WIRE \WDEF020					Philadelphia, PA 19135 (215) 624-4800 FAX (215) 624-6966	DRWN/DATE MFJ 9.10.96

BLK

(2)

(20)

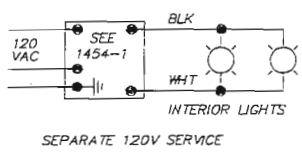
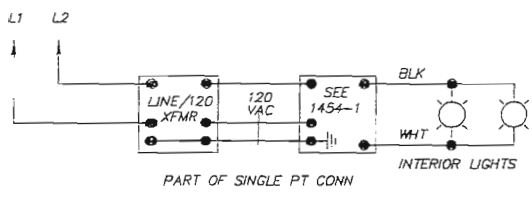
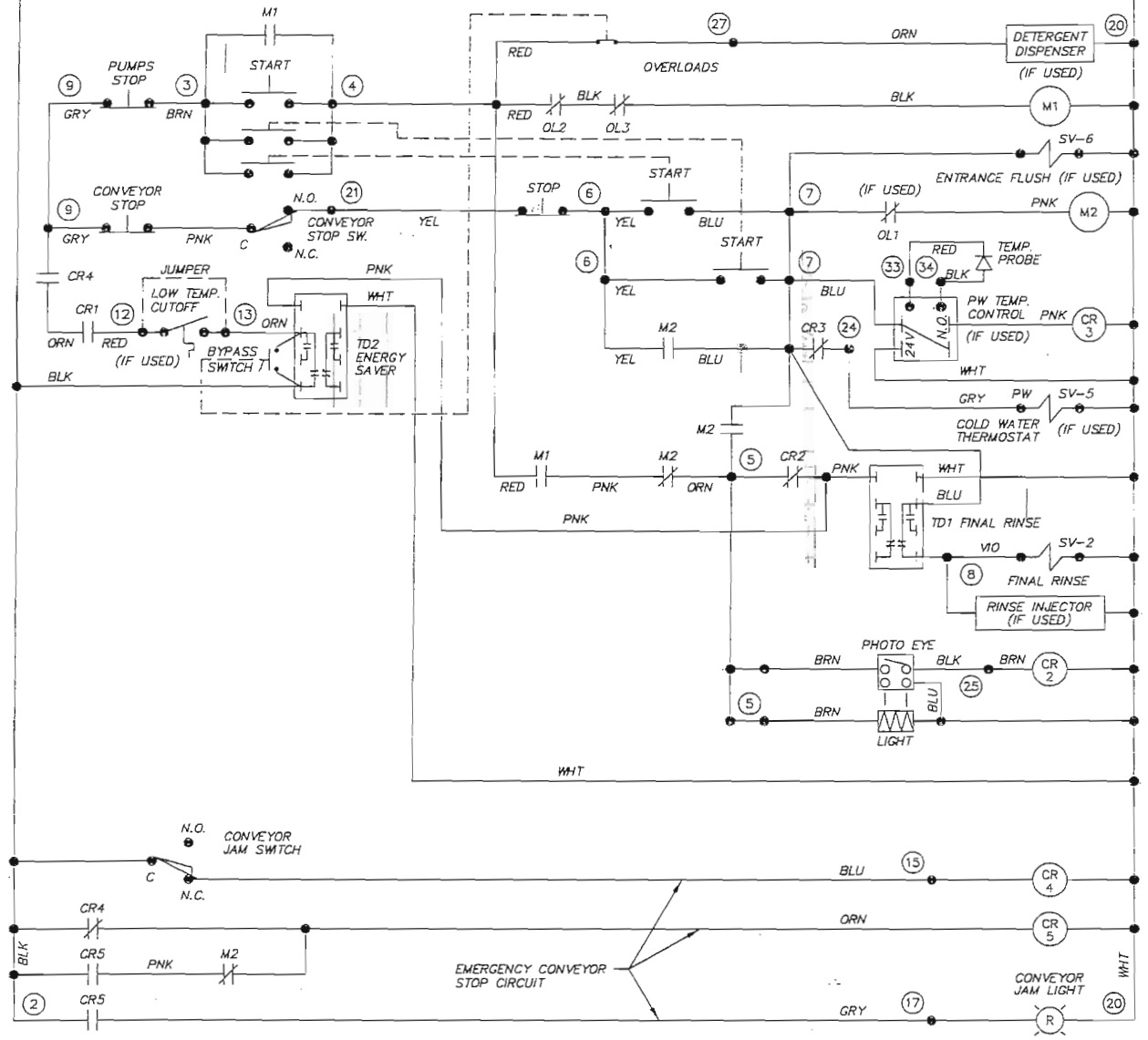

SHEET 2 OF 2

C	1927	3.25.02	TITLE DEFENDER ELECTRIC HEAT	DWG. NO. WDEF020
B	1583	12.1.97		
A	1549	5.20.97		
REV	ECN NO	DATE		Philadelphia, PA 19135 (215) 624-4800 FAX (215) 624-6966
FILE:	WRE\WDEF020			DRWN/DATE MFJ 9.10.96

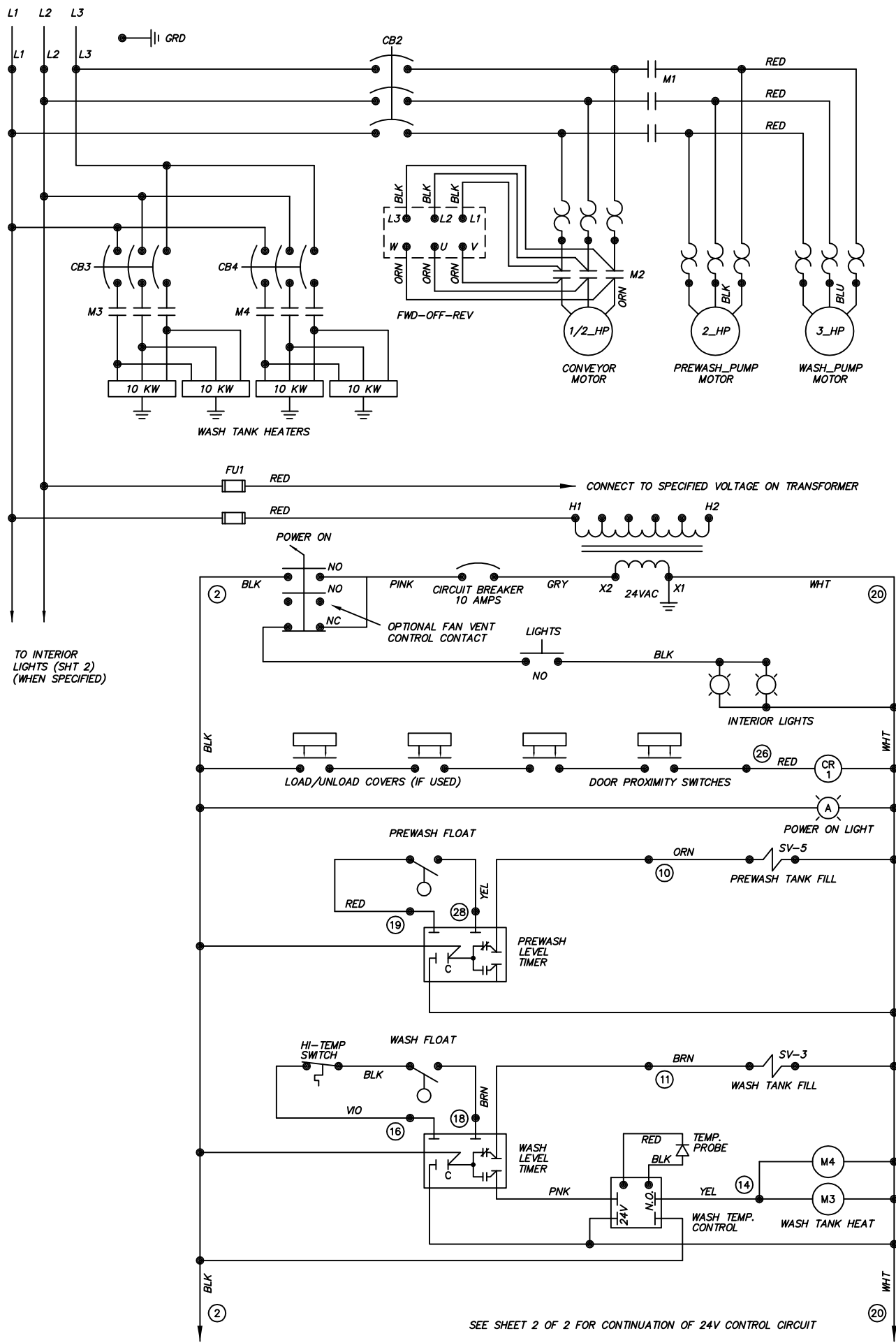

TO INTERIOR LIGHTS (SHT 2) (WHEN SPECIFIED)

SEE SHEET 2 OF 2 FOR CONTINUATION OF 24V CONTROL CIRCUIT

C	-	10.15.24	TITLE	DEFENDER	DWG. NO.	
B	2634	10.15.12	ELECTRIC HEAT (CIRCUIT BRKRS)		WDEF021	
A	2132	2.27.08				
REV	ECN NO	DATE			DRWN/DATE	
			Insinger		(215) 624-4800	MFJ
			Philadelphia, PA 19135		FAX (215) 624-6966	8.18.99
FILE: WIRE\WDEF021						

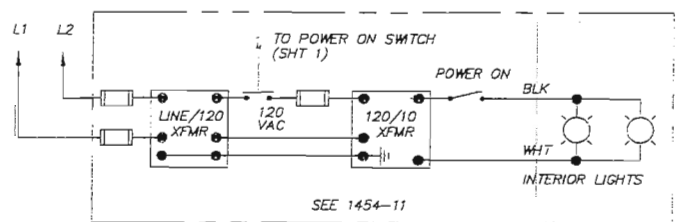
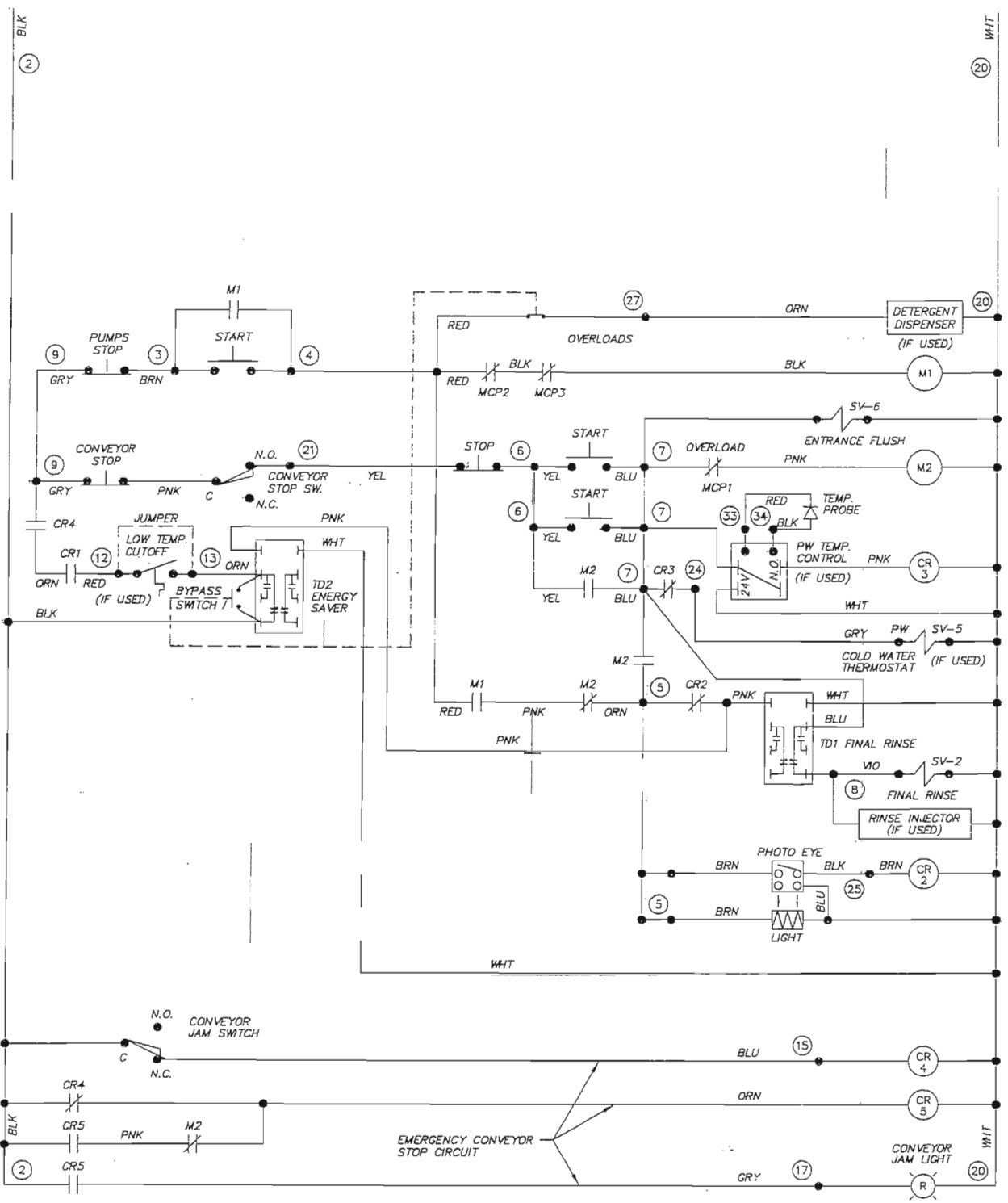

SHEET 2 OF 2

TITLE		DEFENDER		DWG. NO.	
ELECTRIC HEAT (CIRCUIT BRKRS)		WDEF021			
REV	ECN NO	DATE	 Philadelphia, PA 19135 (215) 624-4800 FAX (215) 624-6965	DRWN/DATE	
FILE: WRE\WDEF021				MFJ	8.18.99



PART 5
REPLACEMENT PARTS
FOR CENTURY 14

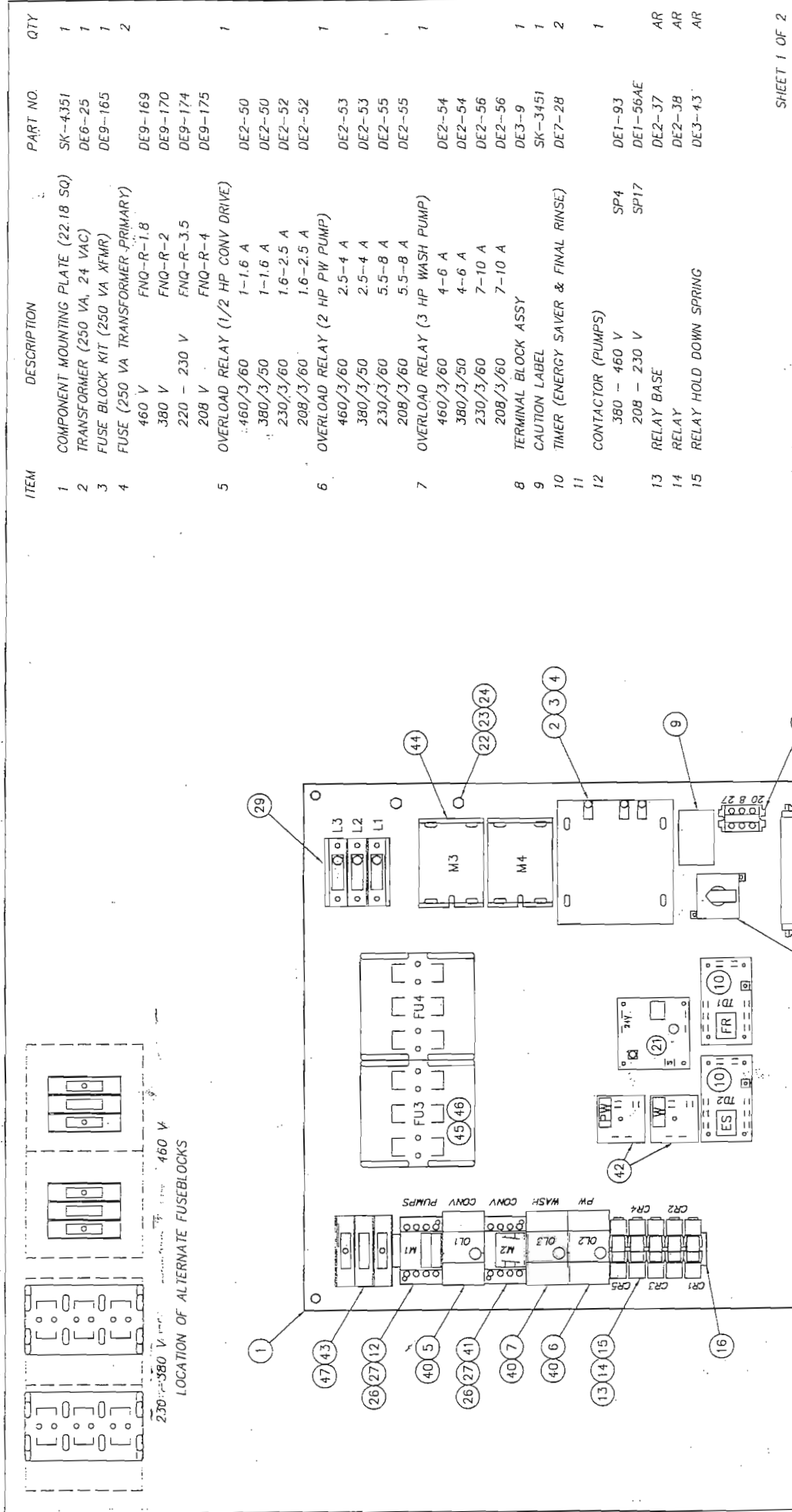

ITEM	DESCRIPTION	PART NO.	QTY
1	COMPONENT MOUNTING PLATE (22.18 SQ)	SK-4351	1
2	TRANSFORMER (250 VA, 24 VAC)	DE6-25	1
3	FUSE BLOCK KIT (250 VA XFMR)	DE9-165	1
4	FUSE (250 VA TRANSFORMER-PRIMARY)	DE9-169	2
	460 V	FNQ-R-1.8	
	380 V	FNQ-R-2	
	220 - 230 V	FNQ-R-3.5	
	208 V	FNQ-R-4	
5	OVERLOAD RELAY (1/2 HP CONV DRIVE)	DE9-174	1
	460/3/60	DE9-175	
	1-1.6 A		
	380/3/50	DE2-50	
	1-1.6 A	DE2-50	
	1.6-2.5 A	DE2-52	
	208/3/60	DE2-52	
	1.6-2.5 A	DE2-52	
6	OVERLOAD RELAY (2 HP PW PUMP)	DE2-53	1
	460/3/60	DE2-53	
	2.5-4 A	DE2-53	
	380/3/50	DE2-53	
	2.5-4 A	DE2-53	
	230/3/60	DE2-55	
	5.5-8 A	DE2-55	
	208/3/60	DE2-55	
	5.5-8 A	DE2-55	
7	OVERLOAD RELAY (3 HP WASH PUMP)	DE2-54	1
	460/3/60	DE2-54	
	4-6 A	DE2-54	
	380/3/50	DE2-54	
	4-6 A	DE2-54	
	230/3/60	DE2-56	
	7-10 A	DE2-56	
	208/3/60	DE2-56	
	7-10 A	DE2-56	
8	TERMINAL BLOCK ASSY	DE3-9	1
9	CAUTION LABEL	SK-3451	1
10	TIMER (ENERGY SAVER & FINAL RINSE)	DE7-28	2
11			
12	CONTACTOR (PUMPS)	DE1-93	1
	380 - 460 V	DE1-93	
	SP4	DE1-56AE	
	208 - 230 V	SP17	
13	RELAY BASE	DE2-37	AR
14	RELAY	DE2-38	AR
15	RELAY HOLD DOWN SPRING	DE3-43	AR

TITLE DEFENDER
ELECT HEAT, NEMA 4X CONTROL PANEL

Philadelphia, PA 19135 DRWN/DATE
(215) 624-4800 MFJ 2.5.97
FAX (215) 624-8966
FILE: SKETCH\SK-3963

INSINGER
SCALE 1/4 DWG. NO. SK-3963

REV	ECN NO.	DATE
G	1945	7.17.02
F	1857	2.15.01

SHEET 1 OF 2

22 3/16 SQ PANEL

ITEM	DESCRIPTION	PART NO.	QTY	ITEM	DESCRIPTION	PART NO.	QTY	ITEM	DESCRIPTION	PART NO.	QTY
16	DIN RAIL (35 mm)	DE9-216	1	33	PILOT LIGHT ASSY - RED	DEB-52	1	44	CONTACTOR (40 KW ELECT WASH TANK HEAT ONL Y)	DE9-186	2
17	DIN RAIL (15 mm)	DE3-42	1	34	PUSHBUTTON ASSY, START-STOP	DE5-3250	1				
18	TERMINAL SECTION	DE3-39	AR	35	CONTACT BLK, NO/NC	DE5-4650	1				
19	TERMINAL END COVER PLATE	DE3-40	1	36	CONTROL BOX, 24 X 24 X 8	DE9-249	1				
20	TERMINAL END CLAMP	DE3-41	2	37	DECAL	SK-3799	1				
21	TEMPERATURE CONTROL BOARD	DE9-251	AR	38	DATA DECAL	SK-3715	1	45	FUSEBLOCK	DE9-186	2
22	GROUNDING STUD	D309G-GC-46	2	39	SWITCH (FWD - OFF - REV)	DEB-56	1				
23	LOCKWASHER, 1/4"	D313C-G5	2	40	OVERLOAD BASE	DE2-60	3				
24	HEX NUT, 1/4-20	D312C-GC-2	2	41	CONTACTOR (CONVEYOR)	DE1-93	1				
25	CONTACT BLOCK, NC	DE5-42AE	1	42	TIMER (LIQUID LEVEL)	DE7-35	2	46	FUSE	DE9-189	6
26	AUX CONTACT NC	DE1-61AE	AR	43	FUSE (MTR CIRCUIT)	DE9-183	3				
27	AUX CONTACT NO	DE1-62AE	AR			DE9-183	3				
28	CIRCUIT BREAKER (10A)	DE9-106	1			DE9-220	1				
29	POWER DIST BLOCK	DE3-152	1			DE9-227	1	47	FUSEBLOCK (3 POLE MTR CIRCUIT)	DE9-186	1
30	SELECTOR SWITCH ASSY	DEB-54	2								
31	CONTACT BLOCK, NO	DE5-41AE	1								
32	PILOT LIGHT ASSY - YELLOW	DEB-53	1								

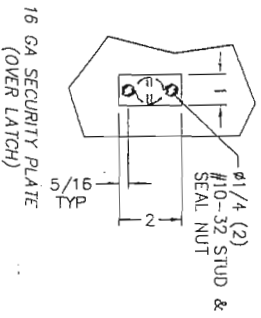
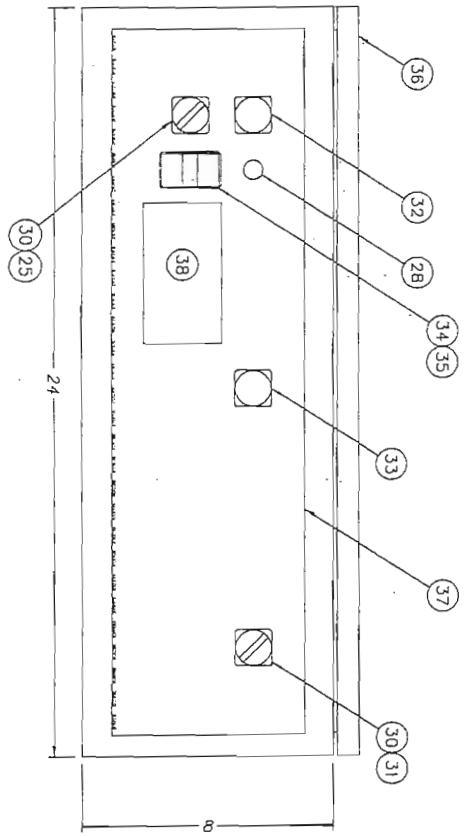

NOT SHOWN
ELECTRIC IMMERSION HEATER (10 KW)
440-480 V, 3 PH
380 V, 3 PH
220-240 V, 3 PH
208V, 3PH
TEMPERATURE SENSOR
AIR

TITLE		DEFENDER	
ELECT HEAT, NEMA 4X CONTROL PANEL		SHEET 2 OF 2	
		Philadelphia, PA 19135 (215) 674-4800 FAX (215) 624-6966	
G 1945 F 1857		DATE 7.17.02 DATE 2.15.01	
SCALE 1/4		DWG. NO. SK-3963	
REV. EON NO.		DATE	

ITEM	DESCRIPTION	PART NO.	QTY
1	COMPONENT MOUNTING PLATE	SK-4354	1
2	TRANSFORMER (250 VA, 24 VAC)	DE6-25	1
3	FUSE BLOCK, 2 POLE (250 VA XFMR)	DE9-185	1
4	FUSE (250 VA TRANSFORMER PRIMARY)		2
	460 V	FNQ-R-1.8	
	380 V	FNQ-R-2	
	220 - 230 V	FNQ-R-3.5	
	208 V	FNQ-R-4	
5	OVERLOAD RELAY (1/2 HP CONV DRIVE)		1
	460/3/60	1-1.6 A	
	380/3/50	1-1.6 A	
	230/3/60	1.6-2.5 A	
	208/3/60	1.6-2.5 A	
6	OVERLOAD RELAY (2 HP PW PUMP)		1
	460/3/60	2.5-4 A	
	380/3/50	2.5-4 A	
	230/3/60	5.5-8 A	
	208/3/60	5.5-8 A	
7	OVERLOAD RELAY (3 HP WASH PUMP)		1
	460/3/60	4-6 A	
	380/3/50	4-6 A	
	230/3/60	7-10 A	
	208/3/60	7-10 A	
8	TERMINAL BLOCK ASSY		1
9	CAUTION LABEL		1
10	TIMER (ENERGY SAVER & FINAL RINSE)		2
	460/3/60	4-6 A	
	380/3/50	4-6 A	
	230/3/60	7-10 A	
	208/3/60	7-10 A	
12	CONTACTOR (PUMPS)		1
	380 - 460 V	SP4	
	208 - 230 V	SPT7	
13	RELAY BASE		AR
14	RELAY		AR
15	RELAY HOLD DOWN SPRING		AR

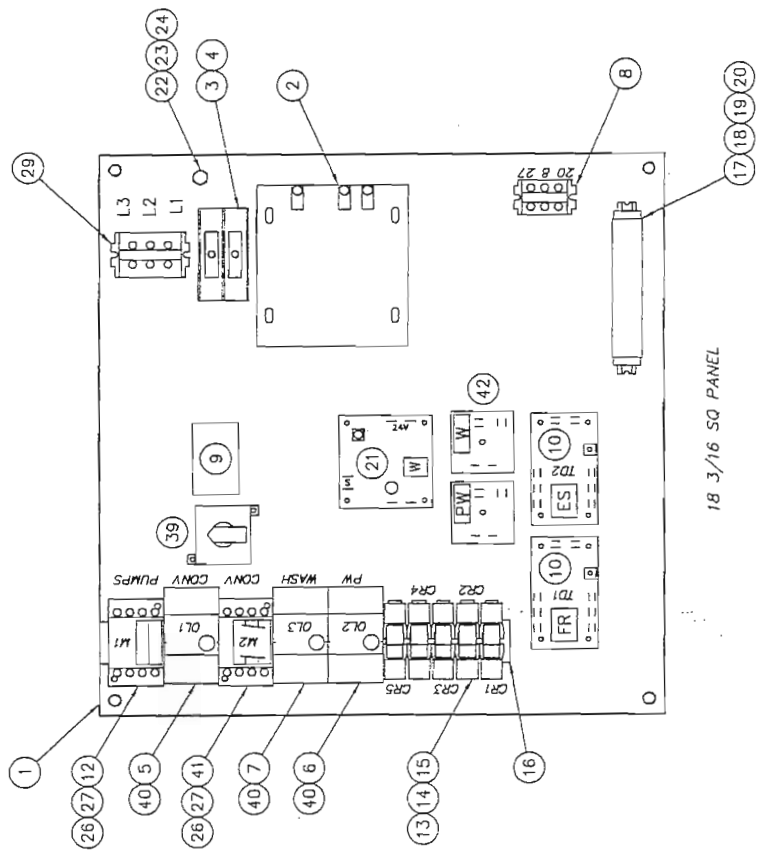

18 3/16 SQ PANEL

TITLE		DEFENDER	
STEAM HEAT, NEMA 4X CONTROL PANEL		Philadelphia, PA 19135 DRWN/DATE	
Insigner		(215) 624-4800 MFJ 12.23.96	
F 1945 7.17.02 FILE: SKETCH\SK-3954		DWG. NO.	
E 1857 2.15.01 SCALE		1/4	
D 1728 1.7.00		REV	
ECN NO		DATE	
		SK-3954	

ITEM	DESCRIPTION	PART NO.	QTY	ITEM	DESCRIPTION	PART NO.	QTY
16	DIN RAIL (35 mm)	DE9-216	1	33	PILOT LIGHT ASSY - RED	DEB-52	1
17	DIN RAIL (15 mm)	DE3-42	1	34	PUSHBUTTON ASSY, START-STOP	DE5-325Q	1
18	TERMINAL SECTION	DE3-39	AR	35	CONTACT BLK, NO/NC	DE5-46SQ	1
19	TERMINAL END COVER PLATE	DE3-40	1	36	CONTROL BOX, 20 X 20 X 6	DE9-245	1
20	TERMINAL END CLAMP	DE3-41	2	37	DECAL	SK-3700	1
21	TEMPERATURE CONTROL BOARD	DE9-251	1	38	DATA DECAL	SK-3715	1
22	GROUNDING STUD	D309C-GC-4G	1	39	SWITCH (FWD - OFF - REV)	DEB-56	1
23	LOOKWASHER, 1/4"	D313C-G5	1	40	OVERLOAD BASE	DE2-60	3
24	HEX NUT, 1/4-20	D312C-GC-2	1	41	CONTACTOR (CONVEYOR)	DE1-93	1
25	CONTACT BLOCK, NC	DE5-42AE	1	42	TIMER (LIQUID LEVEL)	DE7-35	2
26	AUX CONTACT NC	DE1-61AE	AR				
27	AUX CONTACT NO	DE1-62AE	AR				
28	CIRCUIT BREAKER (10A)	DE9-106	1				
29	TERMINAL BLOCK	DE3-3	1				
30	SELECTOR SWITCH ASSY	DEB-54	2				
31	CONTACT BLOCK, NO	DE5-41AE	1				
32	PILOT LIGHT ASSY - YELLOW	DEB-53	1				

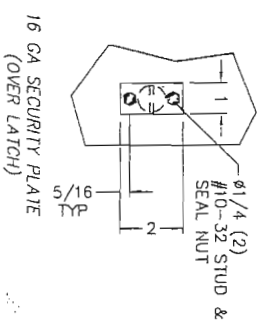
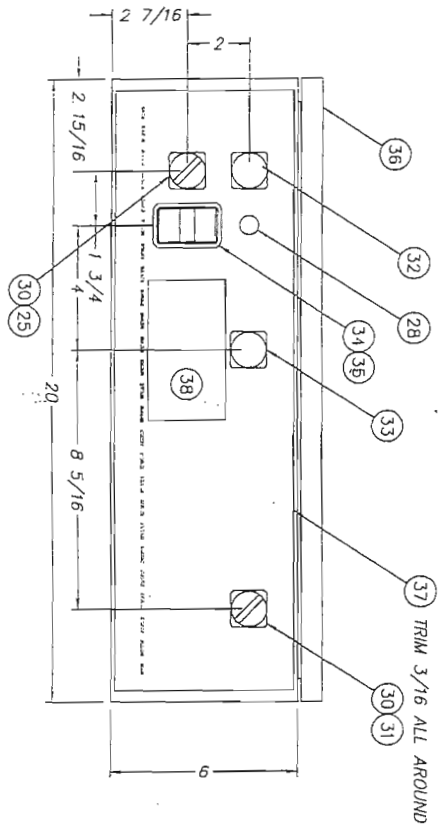

NOT SHOWN:
TEMPERATURE SENSOR DE9-252 AR

TITLE	DEFENDER	
STEAM HEAT, NEMA 4X CONTROL PANEL		
Ininger	Philadelphia, PA 19135 DRWN/DATE	
(215) 624-4800	M/F 12.23.96	
FAX (215) 624-8866		
FILE: SKETCH/SK-3954	SCALE	DWG. NO.
REV	ECN NO	DATE
E 1945	7.17.02	
F 1857	2.15.01	
D 1728	1.7.00	
SK--3954	1/4	

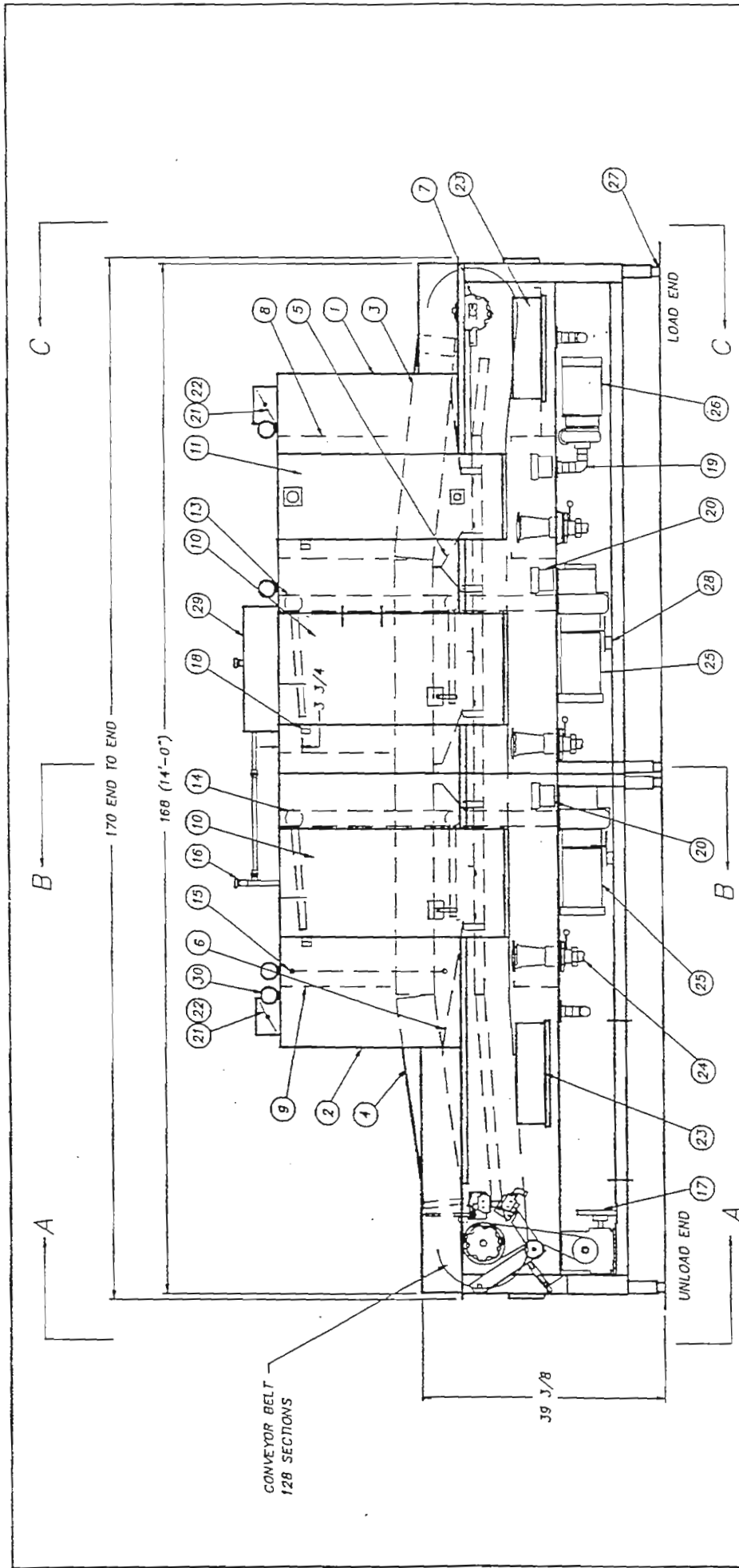

OPTION	DWG. NO.	SIZE
ELECTRIC HEATER LOCATIONS	1390-75	B
STEAM PIPING-WASH & RINSE TANKS	1390-74	B
STEAM PIPING-INJECTORS	1390-96	B
CLOSE-OFF PANELS	1390-81	B

SHEET 1 OF 3

TOLERANCES	±1/64	TITLE	CENTURY 14 RPW-W	TEXT ASSY DWG. NO.	1390-1
FRACTIONS	±.005	REV	R.H. MACHINE	REV	1
DECIMALS	XX ± .01	MAT'L	NOTED	SCALE	1=16
XX ± .01					
ANGLES	±1/2°				
UNLESS OTHERWISE SPECIFIED					
REV. ECH NO	DATE				
A	11.3.93				
FILE: PARTS\1390-1					
				Philadelphia, PA 19135 (215) 624-4800 FAX (215) 624-6866	
				DRWN/DATE PG 4.19.93	

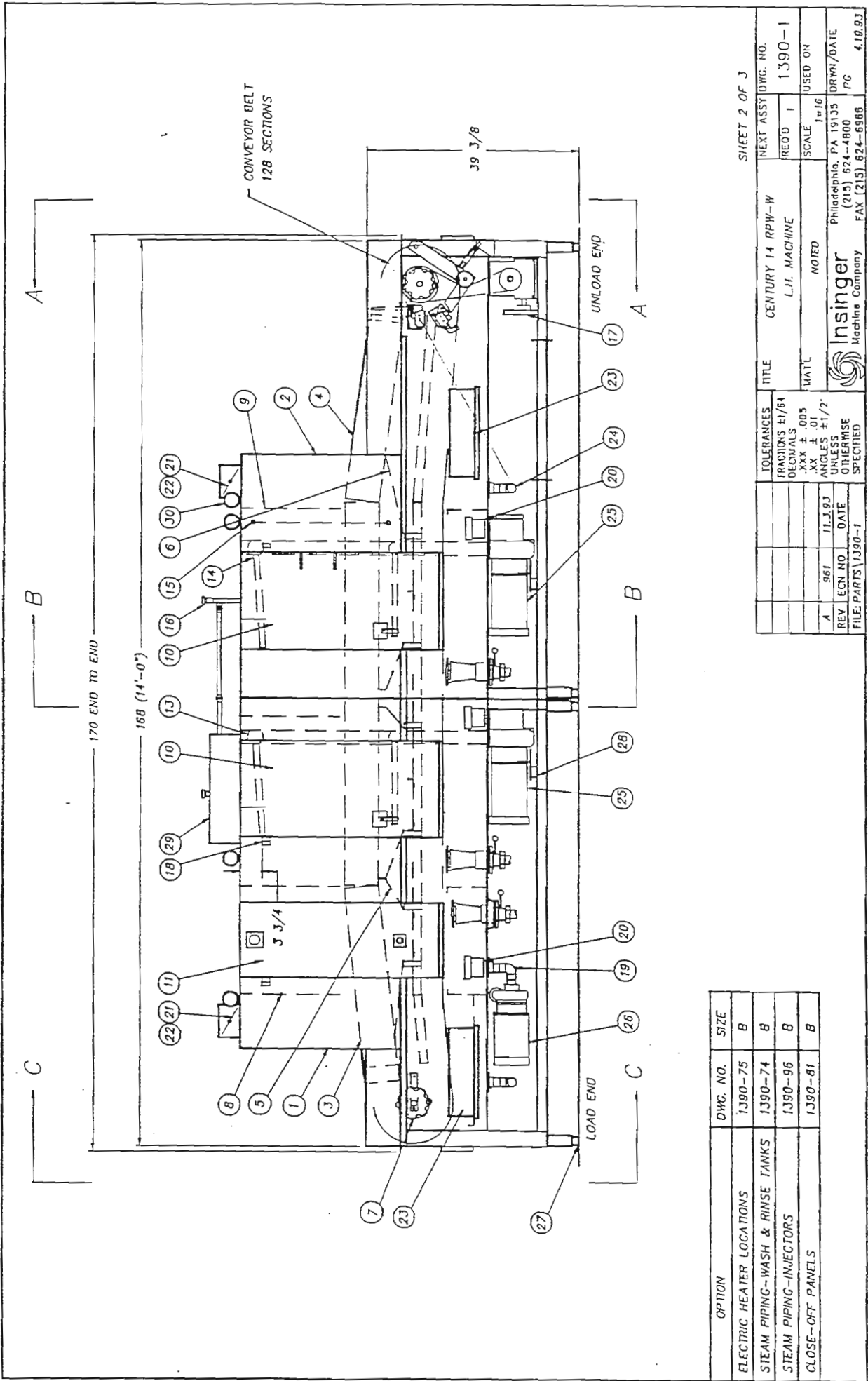

SHEET 2 OF 3

OPTION	DWG. NO.	SIZE
ELECTRIC HEATER LOCATIONS	1390-75	B
STEAM PIPING-WASH & RINSE TANKS	1390-74	B
STEAM PIPING-INJECTORS	1390-96	B
CLOSE-OFF PANELS	1390-81	B

TOLERANCES ±1/64 FRACTIONS ±1/64 DECIMALS .005 XX ± .01 XX ± .01 ANGLES ±1/2° UNLESS OTHERWISE SPECIFIED	REV. ECN NO. DATE A 961 11.3.93	FILE: PARTS\1390-1	INSINGER Machine Company Philadelphia, PA 19135 (215) 624-4800 FAX (215) 624-6968	DRWH/DATE PC 4.10.93
TITLE CENTURY 14 RPIW-W L.H. MACHINE	NOTED	SCALE 1=16	USED OR	1390-1
WATL	NOTED	SCALE	USED OR	1390-1
NEXT ASSY DWG. NO.	1390-1	SCALE	USED OR	1390-1

ITEM	PART NO.	SIZE	DESCRIPTION	QTY.
1	1390-2	B	SHELL ASSEMBLY, LOAD SECTION	1
2	1390-3	B	SHELL ASSEMBLY, UNLOAD SECTION	1
3	1390-4	B	TRACK INSTALLATION, LOAD SECTION	1
4	1390-5	B	TRACK INSTALLATION, UNLOAD SECTION	1
5	1390-6	B	BAFFLES & SCRAP SCREENS, LOAD SECTION	1
6	1390-7	B	BAFFLES & SCRAP SCREENS, UNLOAD SECTION	1
7	1390-8	B	DRIVEN SHAFT ASSEMBLY	1
8	1390-9	B	CURTAIN & BAFFLE INSTALL, LOAD SECTION	1
9	1390-10	B	CURTAIN & BAFFLE INSTALL, UNLOAD SECTION	1
10	1390-31	A	DOOR 19"	2
11	1390-32	A	DOOR 15"	1
12	1390-49	B	WEIR PLATE INSTALL.	1
13	1390-56	B	DISCHARGE LINE ASSY, LOAD SECTION	1
14	1390-57	B	DISCHARGE LINE ASSY, UNLOAD SECTION	1
15	1390-68	B	FINAL RINSE ASSEMBLY	1
16	1390-71	B	AUTO TANK FILL ASSEMBLY	1
17	1390-72	B	CONVEYOR DRIVE ASSEMBLY	1
18	D2715	A	DOOR LATCH	3
19	1182-13	A	SUCTION LINE, PREWASH	1
20	1100-76	A	PUMP SUCTION ASSEMBLY	2
21	D2-728	A	VENT DAMPER BLADE	2
22	D2-831	A	DAMPER ASSEMBLY	2
23	1100-94	A	TANK DOOR	4
24	1390-73	B	DRAIN ASSEMBLY	1
25	3075-K23	-	PUMP WASH, RINSE	2
26	3018-K188	-	PUMP PREWASH	1
27	D2587	A	ADJUSTABLE FOOT ASSY	8
28	D3-815	A	PUMP SPACER	4
29	1282-01	B	CONTROL BOX	1

ITEM	PART NO.	SIZE	DESCRIPTION	QTY.
30	1390-76	B	ACCESSORY LOCATIONS	1
31	1390-77	B	LABEL LOCATION	1
32	D3-727	A	ELECTRICAL CHANNEL	1
33	1390-81	B	CLOSE-OFF PANELS	1
34	1390-95	B	START/STOP STATION	1

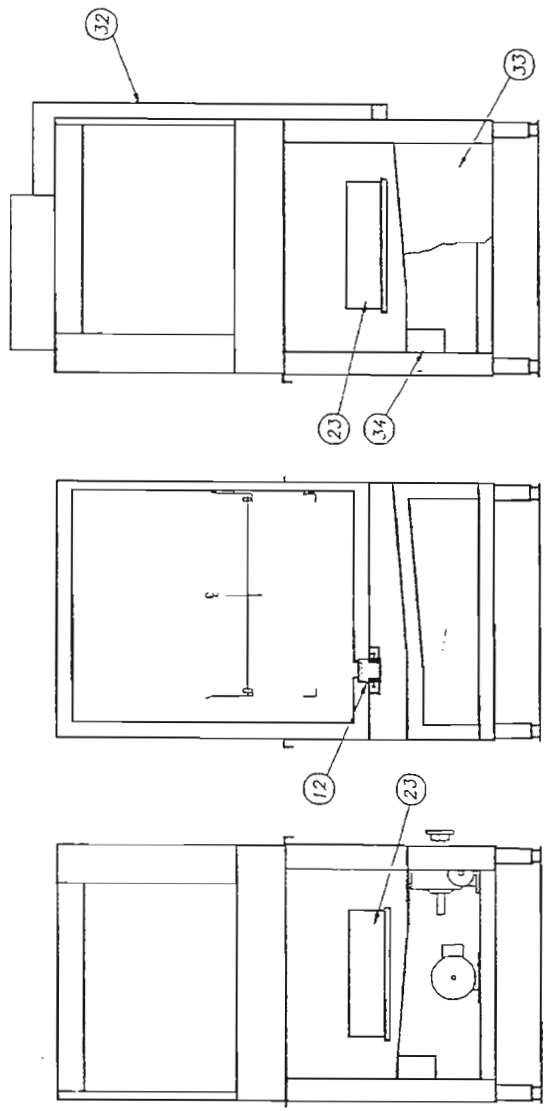

BELT = 128 SECTIONS

SHEET 3 OF 3

TOLERANCES	TITLE	FRACIONS ±1/64	DECIMALS ±0.005	XX ± .01	YY ±	ZZ ± 1/2"	UNLESS OTHERWISE SPECIFIED
	CENTURY 14 RPW-W R.H.MACHINE						
	MATL	NOTED	SCALE	1=16	USED ON		
A	061	71.3.03	DATE				
REV	ECN NO						
FILE:PARTS\1390-1							
	Insinger Machine Company	Philadelphia, PA 19135	(215) 824-4800	FAX (215) 824-6866	PC	4.18.93	

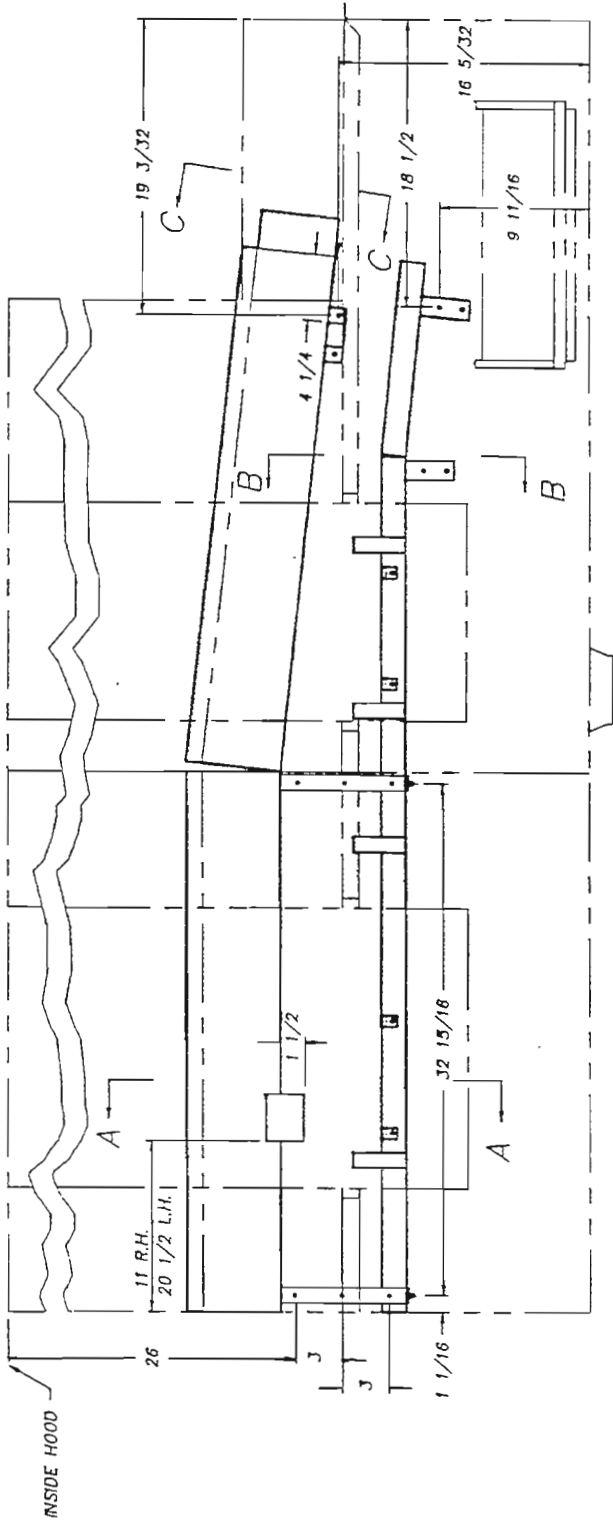

LOAD END

SPUT END

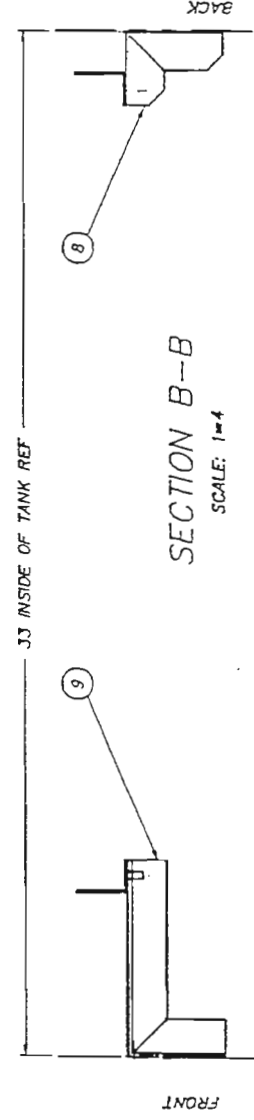

SECTION B-B
SCALE: 1=4

R.H. MACH. SHOWN		L.H. MACH. OPPOSITE		SHEET 1 OF 2	
TOLERANCES	TITLE	TRACK INSTALLATION	NEXT ASSY DWG. NO.	1390-1	1390-4
FRACTIONS ±1/64	LOAD SECTION	NOTED	SCALE	1=8	USED ON
DECIMALS .XXX ±.005					CENTURY
.XX ±.01					PG
ANGLES ±1/2°					DRWN/DATE
UNLESS OTHERWISE SPECIFIED					PG
REV	LEGN NO.	DATE	Philadelphia, PA 19135 (215) 624-4800 FAX (215) 624-6888		
FILE: PARTS\1390-4			Insinger Machine Company Philadelphia, PA 19135 (215) 624-4800 FAX (215) 624-6888 J.25.03		

ITEM	PART NO.	SIZE	DESCRIPTION	QTY.
1	1390-39	B	TRACK LOWER-FRONT	1
2	1390-39	B	TRACK LOWER-BACK	1
3	1390-38	B	TRACK UPPER-FRONT	1
4	1390-36	B	TRACK UPPER-BACK	1
5	1100-50	B	TRACK SUPPORT	2
6	1100-50A	A	SHIM	4
7	1100-55	B	TRACK SUPPORT UPPER	1
8	1100-152	A	TRACK SUPPORT LOWER REAR	2
9	1100-56	A	TRACK SUPPORT LOWER FRONT	2
10	1100-58	A	SUPPORT BAR INSTALLATION	4
11	1390-70	A	CRADLE SUPPORT	2

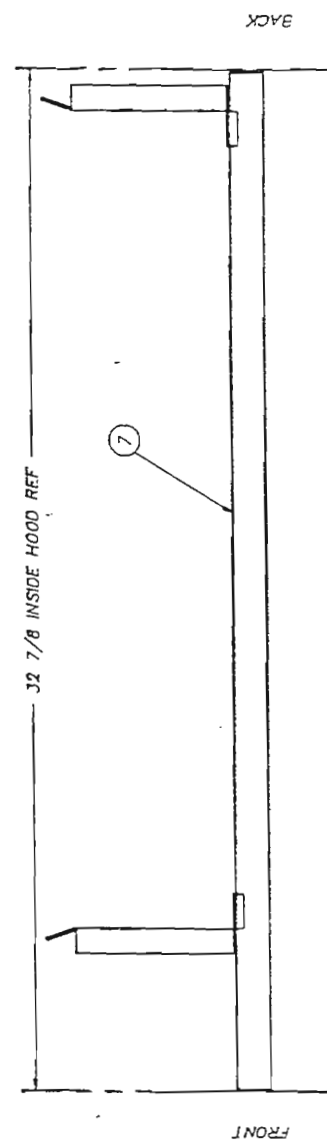
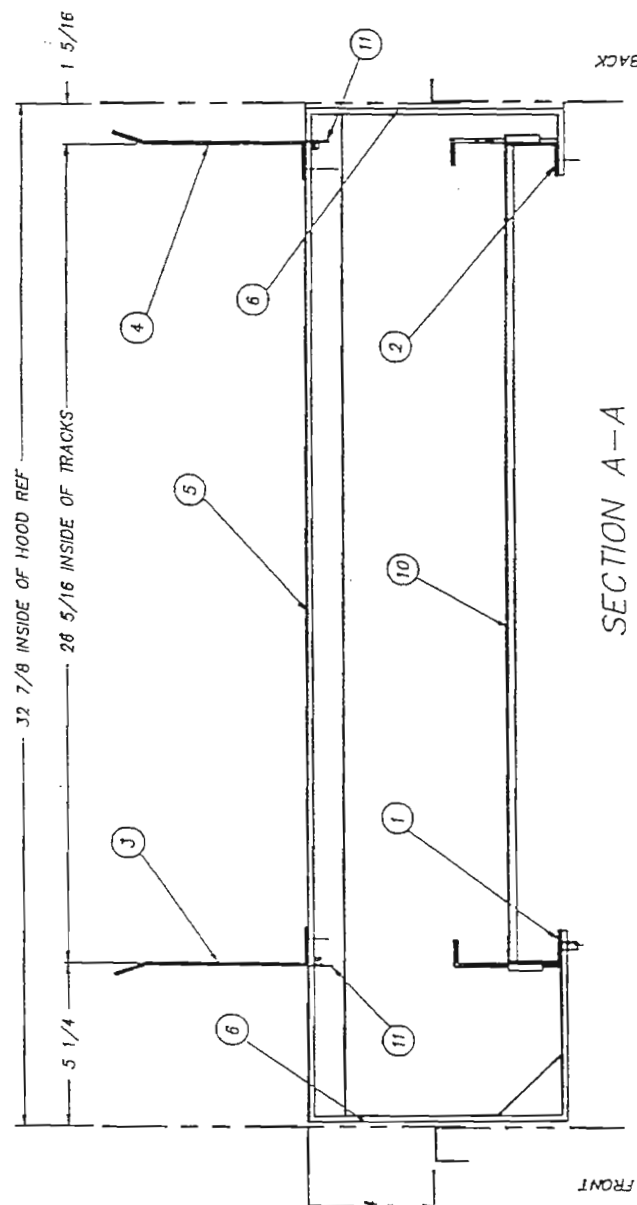

R.H. MACH. SHOWN L.H. MACH. OPPOSITE SHEET 2 OF 2

TOLERANCES	TITLE	REV. ASSY	NO.
FRACTIONS ±1/8"	TRACK INSTALLATION	1390-1	1390-4
DECIMALS	LOAD SECTION	RECD 1	
.XXX ±.005	MAT'L	SCALE	USED ON
.XX ±.01	NOTED	1=8	CENTURY
ANGLES ±1/2°			DRWN/DATE
UNLESS OTHERWISE SPECIFIED			PG

INSINGER Machine Company Philadelphia, PA 19135
(215) 824-4800 FAX (215) 924-8888
J.25.93

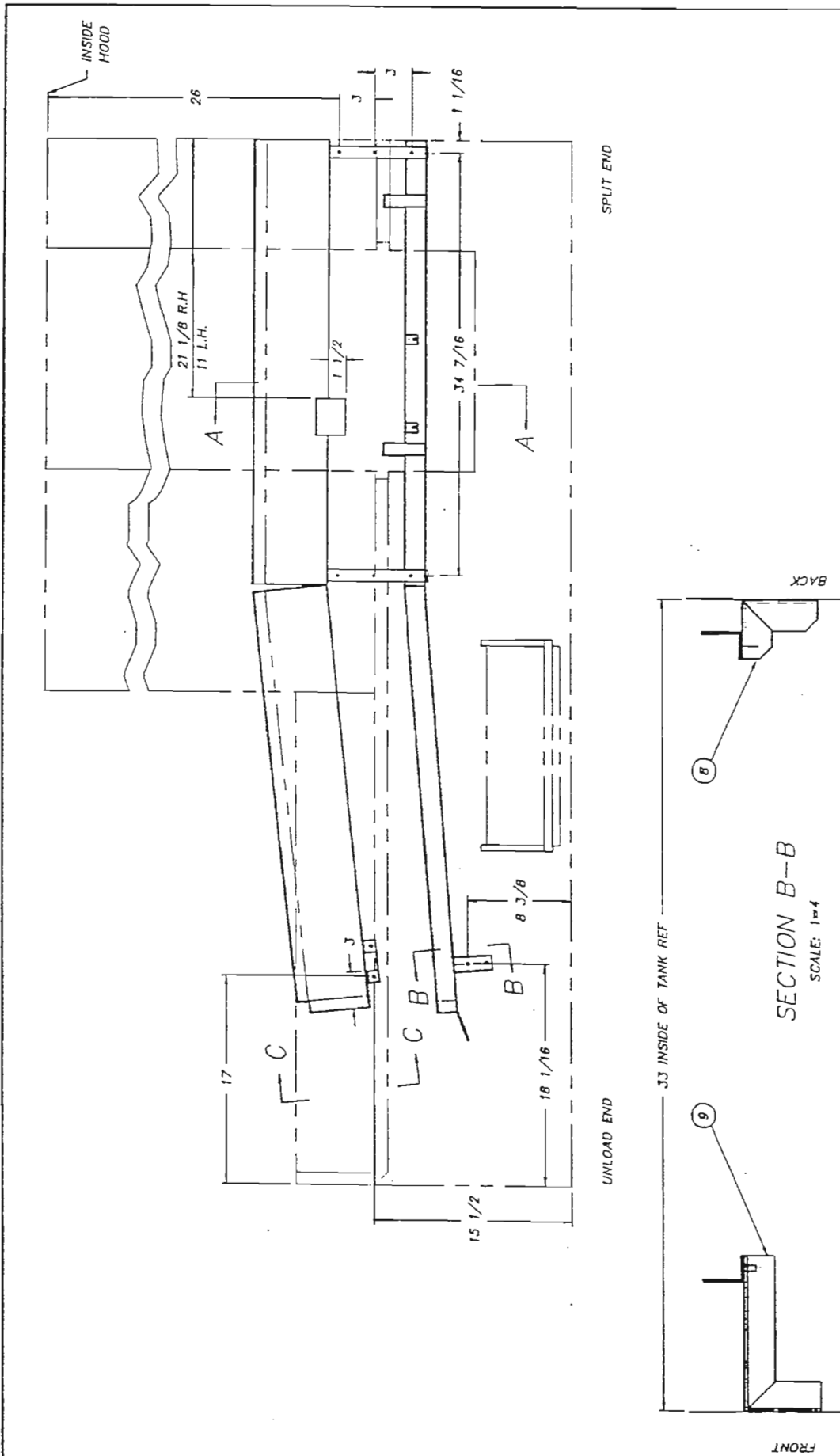

R.H. MACH. SHOWN L.H. MACH. OPPOSITE		SHEET 1 OF 2	
TOLERANCES	TITLE	TRACK INSTALLATION	NEXT ASSY DWG. NO.
FRACTIONS ±1/64	MATL	UNLOAD SECTION	1390-1
DECIMALS .XXX ± .005	AS NOTED		1390-5
.XX ± .01			
ANGLES ±1/2°			
UNLESS OTHERWISE SPECIFIED			
REV	ECH NO.	DATE	USED ON
FILE: PARTS\1390-6			CENTURY
			DIRTY/DATE
			PC
			J.25.93

Insinger
 Machine Company
 Philadelphia, PA 19135
 (215) 624-4000
 FAX: (215) 624-8868

ITEM	PART NO.	SIZE	DESCRIPTION	QTY.
1	1390-40	B	TRACK LOWER-FRONT	1
2	1390-40	B	TRACK LOWER-BACK	1
3	1390-37	B	TRACK UPPER-FRONT	1
4	1390-37	A, B	TRACK UPPER-BACK	1
5	1100-50	B	TRACK SUPPORT	2
6	1100-50A	A	SHIM	4
7	1100-55	B	TRACK SUPPORT UPPER	1
8	1100-152	A	TRACK SUPPORT LOWER REAR	1
9	1100-56	A	TRACK SUPPORT LOWER FRONT	1
10	1100-58	A	SUPPORT BAR INSTALLATION	2
11	1390-70	A	CRADLE SUPPORT	2

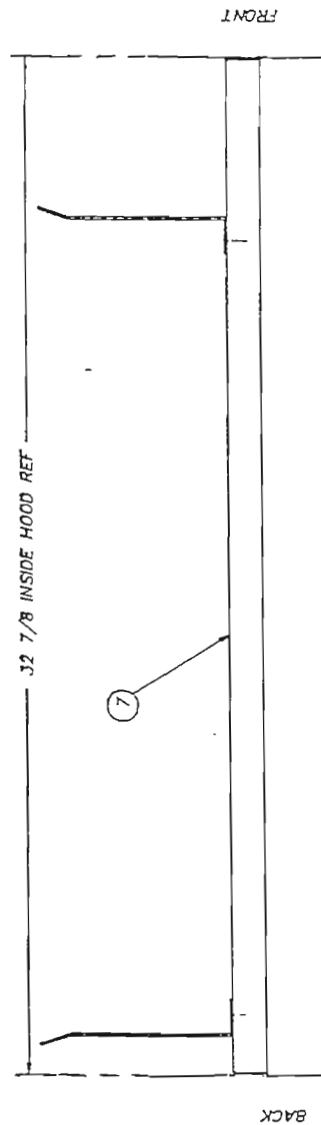
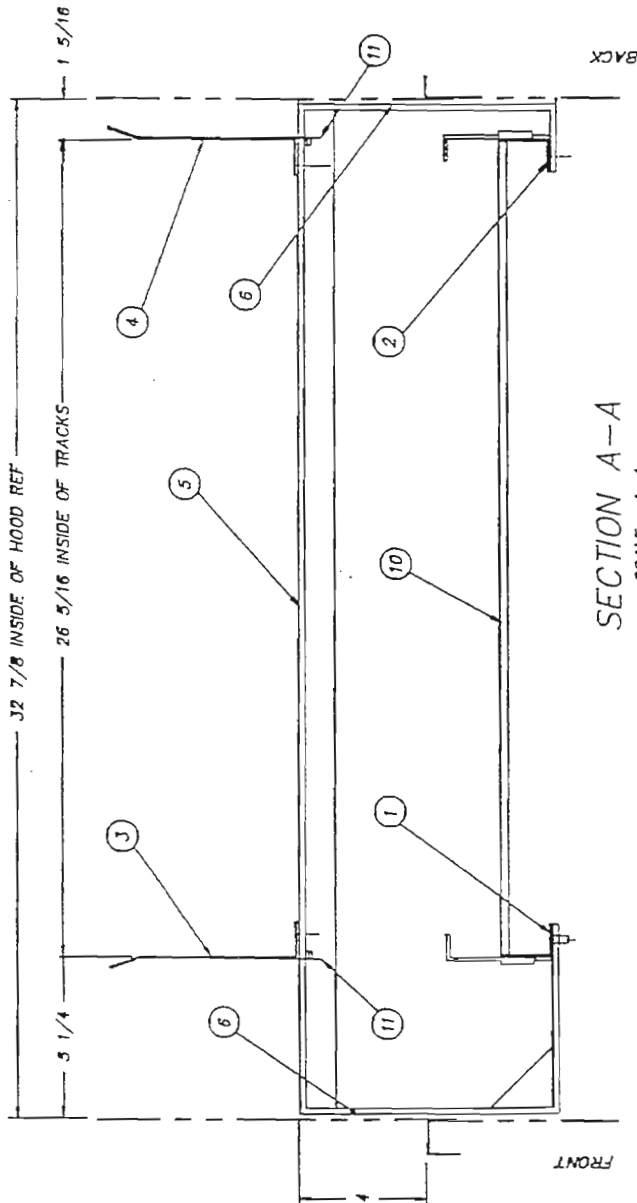

SHEET 2 OF 2

TOLERANCES	TITLE	TRACK INSTALLATION	REV	1	1390-5
FRACTIONS ±1/64	TRACK INSTALLATION	UNLOAD SECTION	SCALE	1=8	USED ON
DECIMALS	UNLOAD SECTION	NOTED	CENTURY		
.XXX ± .009	MATL		DRWN/DATE		
.XX ± .01			PG		
ANGLES ±1/2°					
UNLESS OTHERWISE SPECIFIED					
REV	ECN NO.	DATE	 Insinger Machine Company Philadelphia, PA 19135 (215) 824-4600 FAX (215) 824-6886		
FILE: PARTS\1390-6					

ITEM PART NO.	SIZE	DESCRIPTION	QTY.
1	A	BAFFLE	1
2	A	BAFFLE	1
3	A	BAFFLE	1
4	A	BAFFLE	1
5	A	SCRAP SCREEN	J
6	B	SCRAP SCREEN	1
7	A	SCRAP SCREEN	1
8	A	SUPPORT RAIL	1
9	--	WELDSTUD 1/4 X 3/4 L.G.	5

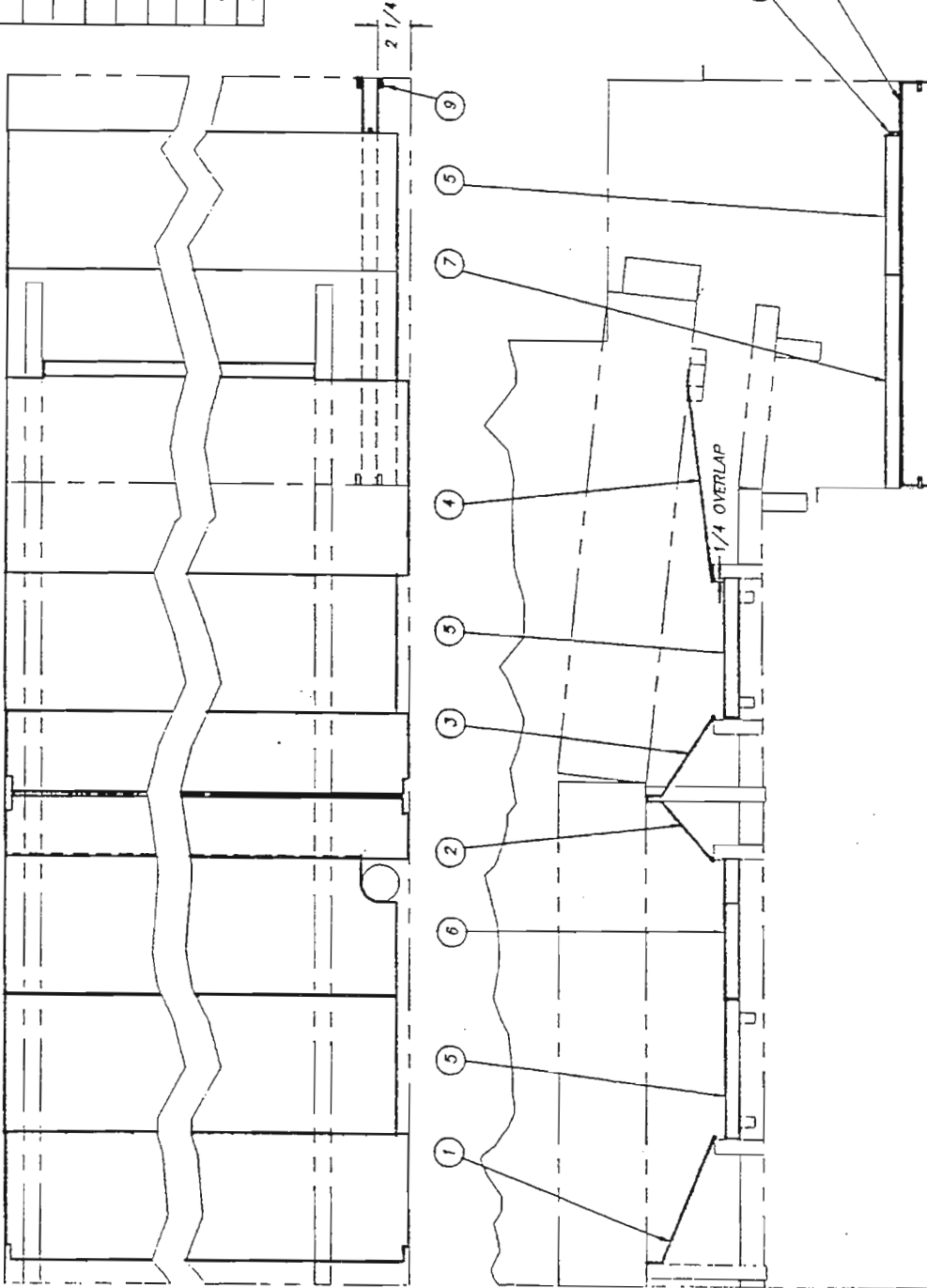

R.H. MACHINE SHOW

NEXT ASSY DWG. NO. 1390-1
SHEET 1 OF 2

TOLERANCES	TITLE	BAFFLES & SCRAP SCREEN	LOAD SECTION	SCALE	1=8	USED ON	CENTURY
FRACTIONS ±1/8"	DATE						
DECIMALS .XXX ±.005	REV						
.XX ±.01	ECH NO						
ANGLES ±1/2°	DATE						
UNLESS OTHERWISE SPECIFIED	FILE: PARTS\1390-6						

insinger
Machine Company

Philadelphia, PA 19135
(215) 624-4800
FAX (215) 624-8986

IJO.93

ITEM	PART NO.	SIZE	DESCRIPTION	QTY.
1	1390-43	A	BAFFLE	1
2	1390-42	A	BAFFLE	1
3	1390-44	A	BAFFLE	1
4	1390-45	A	BAFFLE	1
5	1100-61	A	SCRAP SCREEN	3
6	1390-46	B	SCRAP SCREEN	1
7	1100-37	A	SCRAP SCREEN	1
8	1390-47	A	SUPPORT RAIL	1
9	D309C-GP-6G	-	WELDSTUD 1/4 X 3/4 LG.	5

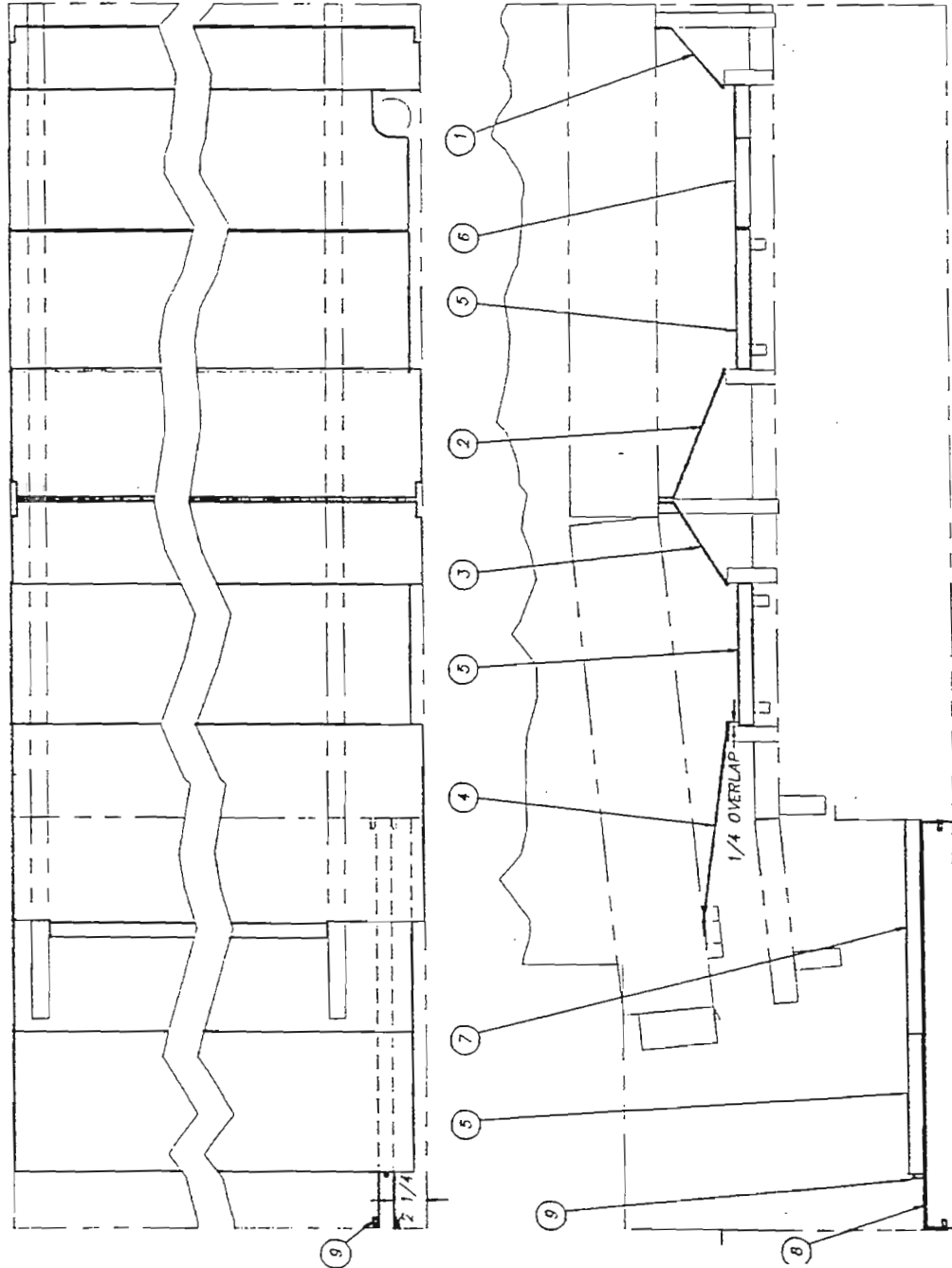

L.H. MACHINE SHOWN SHEET 2 OF 2

TOLERANCES FRACTIONS ±1/64 DECIMALS .XXX ± .005 .XX ± .01 ANGLES ±1/2° UNLESS OTHERWISE SPECIFIED	TITLE	BAFFLES & SCRAP SCREEN	NEXT ASSY DWG. NO.	1390-6
	LOAD SECTION	SCALE	1=8	USED ON CENTURY
REV	ECN NO	DATE	Philadelphia, PA 19135 (215) 624-4800 FAX (215) 624-6066	
FILE:PARTS\1390-6				

ITEM	PART NO.	SIZE	DESCRIPTION	QTY.
1	1390-43	A	BAFFLE	1
2	1390-48	A	BAFFLE	1
3	1100-61	A	SCRAP SCREEN	1
4	1390-46	B	SCRAP SCREEN	1

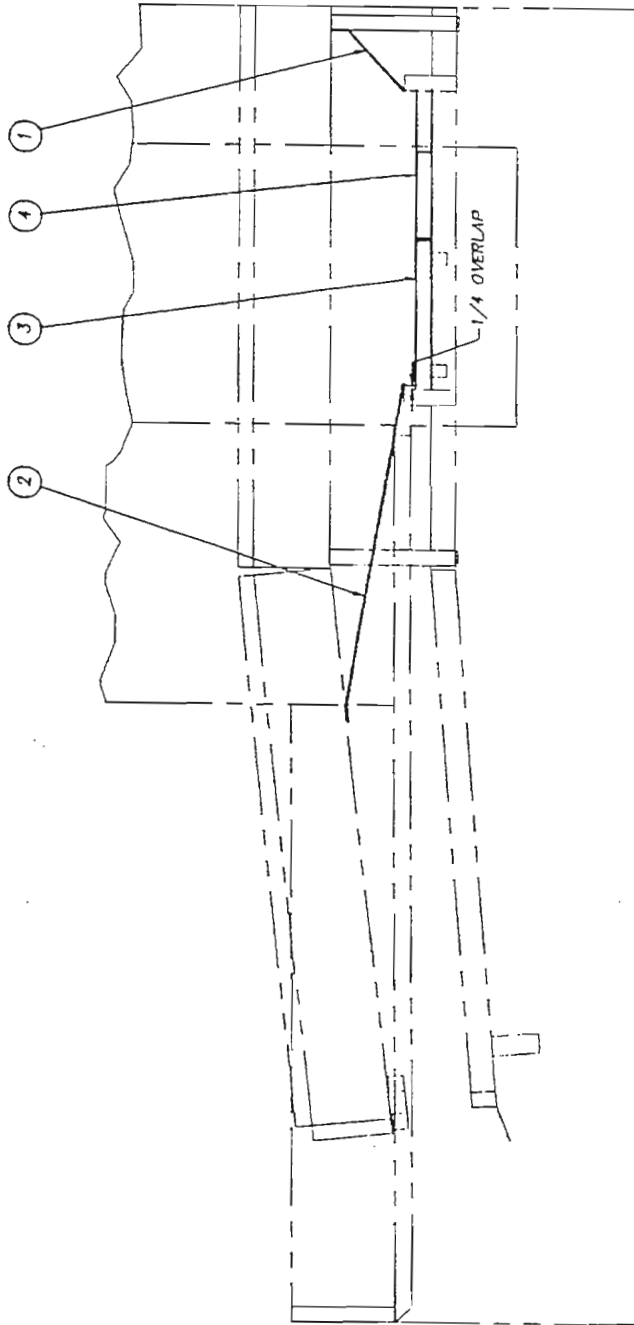

TOLERANCES		TITLE		R.H. MACHINE SHOWN		SHEET 1 OF 2	
FRACTIONS	±1/64	BAFFLES & SCRAP SCREEN	NEXT ASSY DWG. NO.	1390-1	1390-7	RECD	1
DECIMALS	.XXX ± .005	UNLOAD SECTION	SCALE	1=8	USED ON	CENTURY	
ANGLES	± .01	NOTED					
OTHERWISE	±1/2°						
OTHERWISE	SPECIFIED						
REV	ECN NO.	DATE	Philadelphia, PA 19135 (215) 624-4800 FAX (215) 624-8888				
FILE: PARTS\1390-7							

ITEM	PART NO.	SIZE	DESCRIPTION	QTY.
1	1390-42	A	BAFFLE	1
2	1390-79	A	BAFFLE	1
3	1100-61	A	SCRAP SCREEN	1
4	1390-46	B	SCRAP SCREEN	1

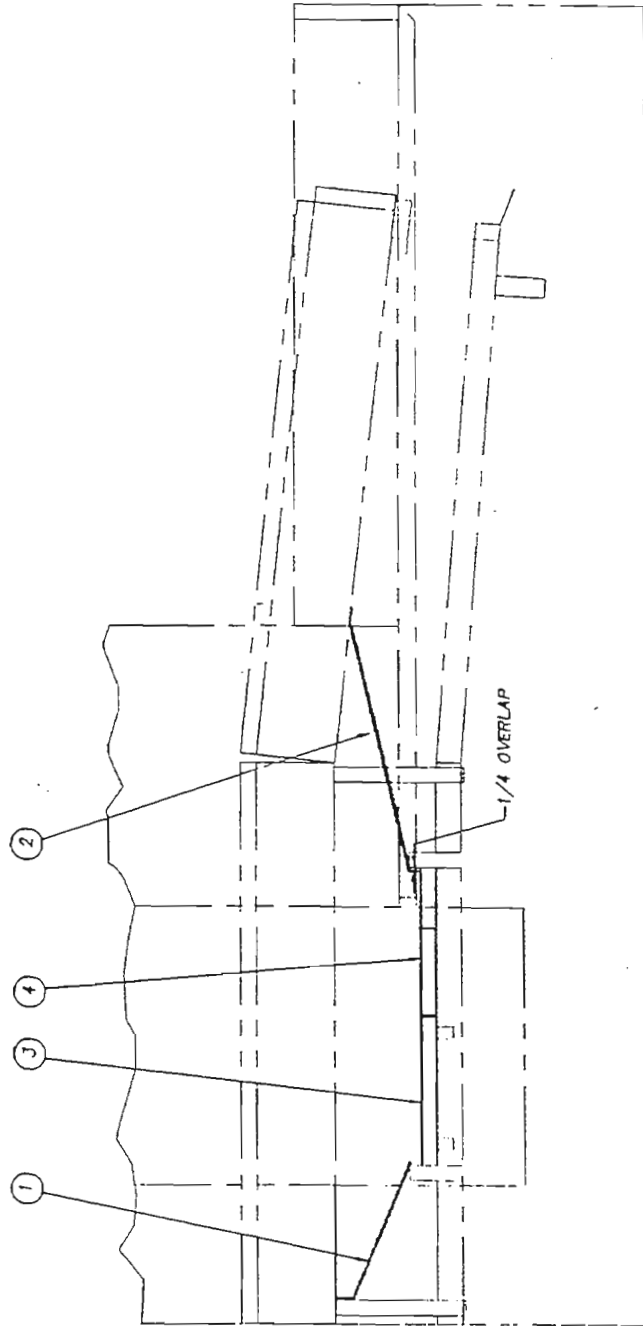

L.H. MACHINE SHOWN

SHEET 2 OF 2

TOLERANCES	TITLE	NEXT ASSY DWG. NO.	1390-1
FRACTIONS ±1/4	BAFFLES & SCRAP SCREEN	REV'D	1
DECIMALS	UNLOAD SECTION	SCALE	1=8
.XXX ±.005	NOTED	USED ON	CENTURY
.XX ±.01		DRWR/DATE	PC
ANGLES ±1/2°			
UNLESS OTHERWISE SPECIFIED			
REV. ECN NO. DATE			
FILE: PARTS\1390-7	Philadelphia, PA 19133 (215) 624-4800 FAX (215) 624-8988		

ITEM	PART NO.	SIZE	DESCRIPTION	QTY.
1	D2-138	A	SPROCKET- BELT	2
2	1100-146	A	SHAFT - DRIVEN	1
3	D2-848	A	COLLAR	4
4	1390-50	A	CHANNEL	2
5	D312C-GC-2	-	HEX NUT S/S 1/4-20	4
6	1390-51	A	ADJUSTING SCREW	2
7	D2-839	A	COLLAR	2
8	D-585	-	"O" RING (01-014)	2
9	D312C-LC-2	-	HEX NUT S/S 1/2-13	2

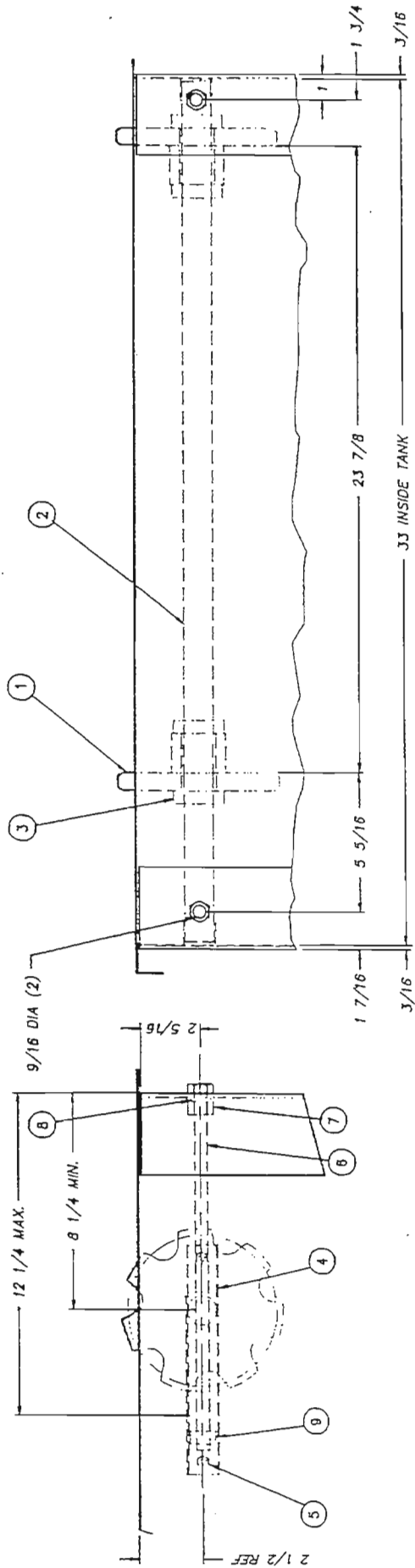

R.H. SHOWN - L.H. OPPOSITE

TOLERANCES		TITLE		REV. ASSY/DWG. NO.	
FRACTIONS ±1/64	DECIMALS ±0.005	DRIVEN SHAFT	1390-8	1390-8	1390-8
XX ±.01	XX ±.01	ASSEMBLY	1	1	1
ANGLES ±1/2°	UNLESS OTHERWISE SPECIFIED	NOTED	1-4	1-4	1-4
REV. ECH. NO.	DATE	FILE: PARTS\1390-8			
FILE: PARTS\1390-8					



Insinger
Machin. Company
Philadelphia, PA 19135
(215) 824-4800
FAX (215) 824-6868

USED ON
CENTURY
PC
J. JI. 93

ITEM	PART NO.	SIZE	DESCRIPTION	QTY.
1	1390-83-1	A	TOP BAFFLE	1
2	1390-54	A	TOP BAFFLE	2
3	1390-52	A	SIDE BAFFLE	1
4	0-761B	A	CURTAIN ROD CLIP	8
5	02-522-1	A	SPLASH GUARD CURTAIN	J
6	02-522-3	A	SPLASH GUARD CURTAIN	1

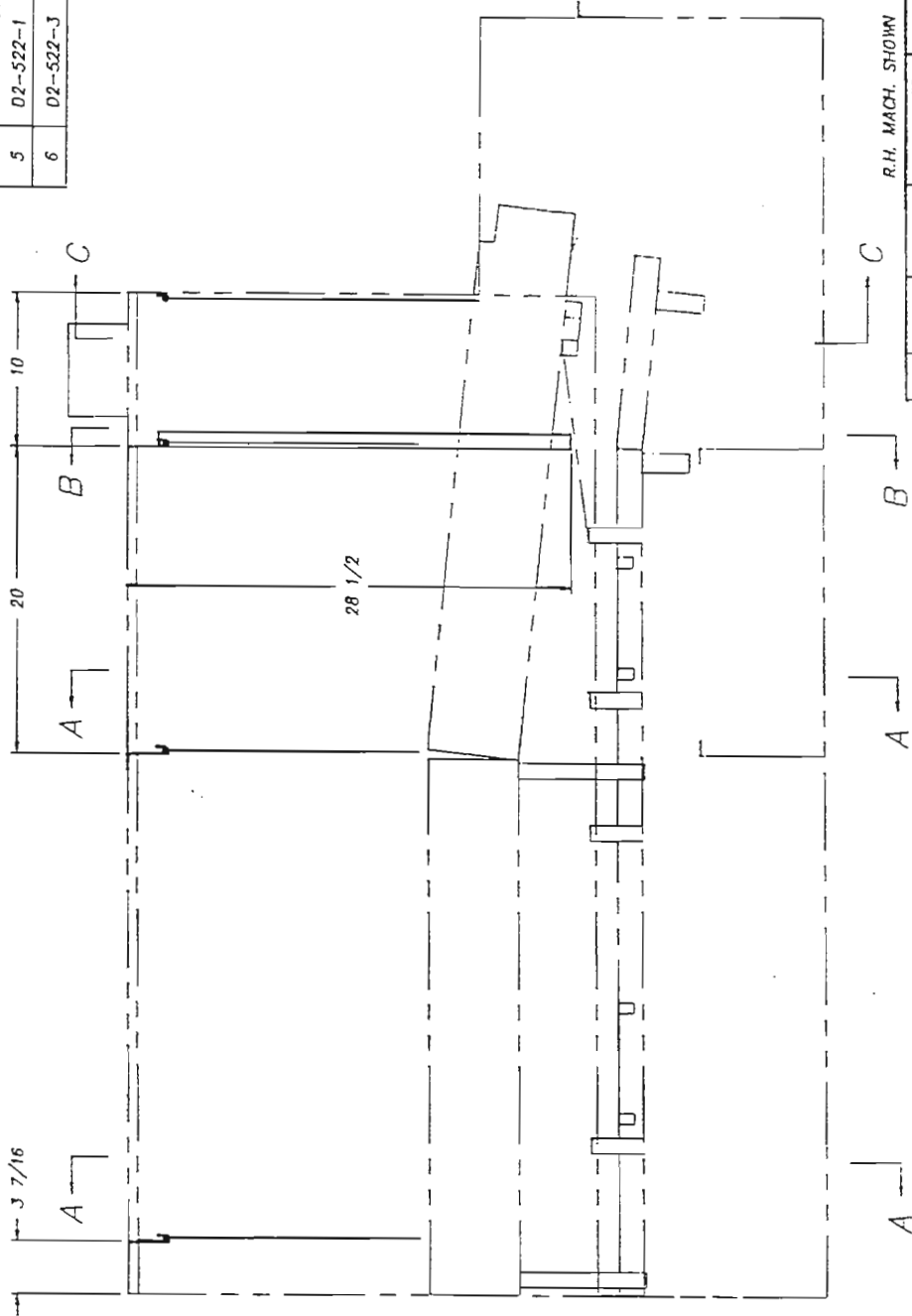

R.H. MACH. SHOWN L.H. MACH. OPPOSITE SHEET 1 OF 2

TOLERANCES	TITLE	NEXT ASSY DWG. NO.
FRACTIONS ±1/64	CURTAIN & BAFFLE INSTALL.	1390-1
DECIMALS	LOAD SECTION	REQD 1
.XXX ± .005	MATL	SCALE 1=8
.XX ± .01	NOTED	USED ON
ANGLES ±1/2°		CENTURY
UNLESS OTHERWISE SPECIFIED		DRWN/DATE
		PC

REV ECN NO. DATE
A 1004 4.25.84

FILE: PARTS\1390-9

Insinger
Machine Company
Philadelphia, PA 19135
(215) 824-4000
FAX (215) 824-6866

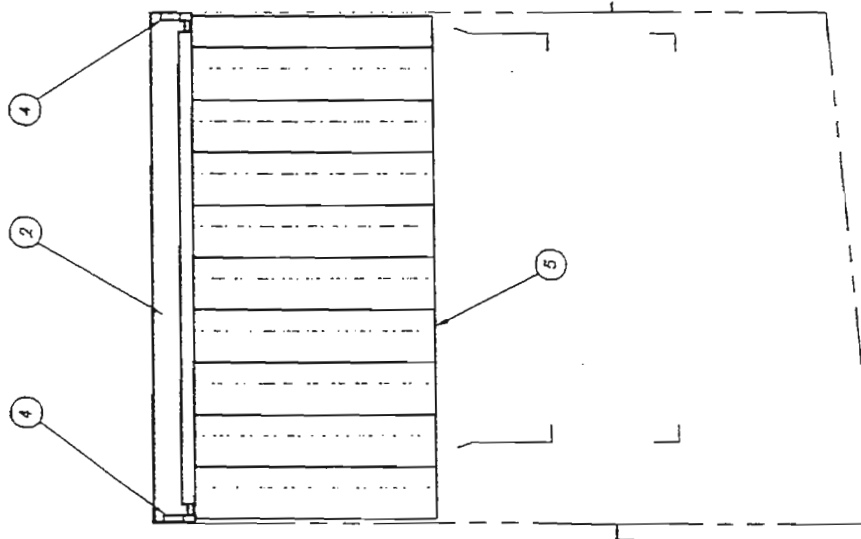

SECTION A--A

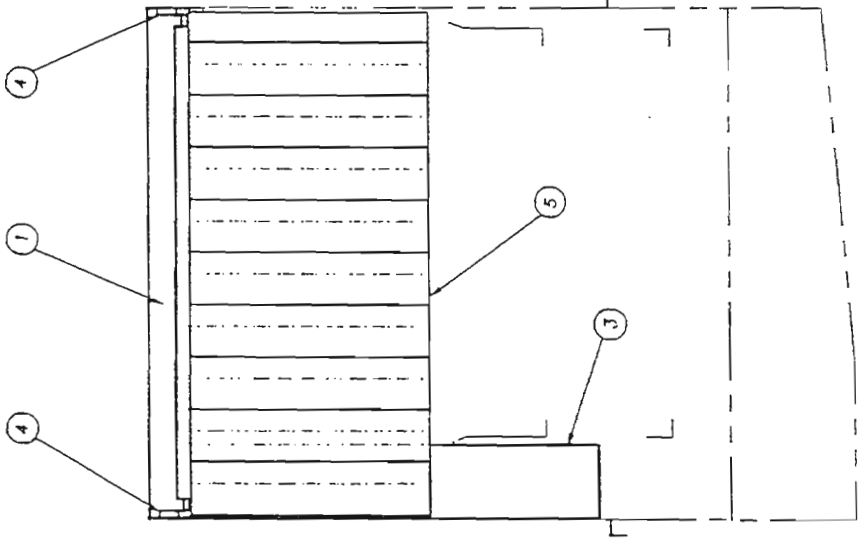

SECTION B--B

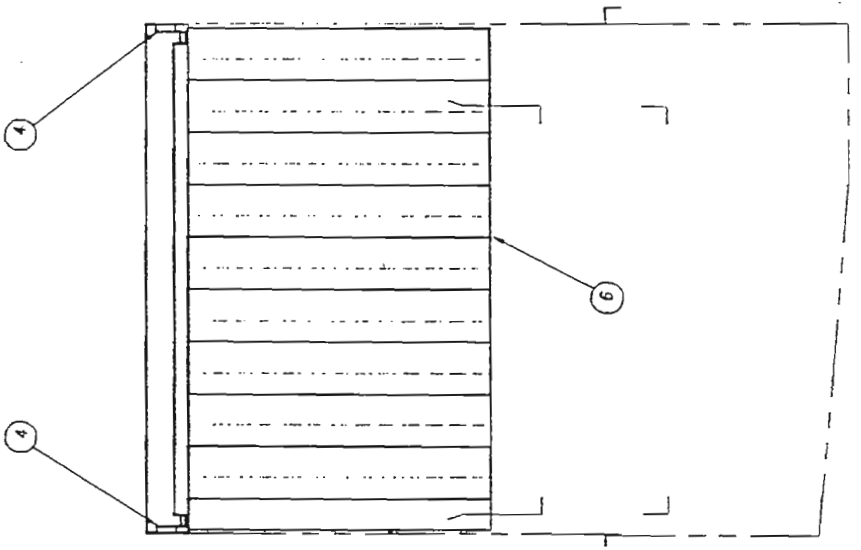

SECTION C--C

R.H. MACH. SHOWN		L.H. MACH. OPPOSITE		SHEET 2 OF 2	
TOLERANCES		TITLE		NEXT ASSY DWG. NO.	
FRACTIONS ±1/64		CURTAIN & BAFFLE INSTALL		1390-1	
DECIMALS		LOAD SECTION		SCALE	
.XXX ± .005		NOTED		1-6	
.XX ± .01		INSINGER		USED ON	
ANGLES ±1/2°		Machine Company		CENTURY	
UNLESS OTHERWISE SPECIFIED		Philadelphia, PA 19135		DRAWN/DATE	
REV		4.25.84		PC	
ECH NO		DATE		4.1.83	
FILE: PARTS\1390-P		R.H. MACH. SHOWN		L.H. MACH. OPPOSITE	

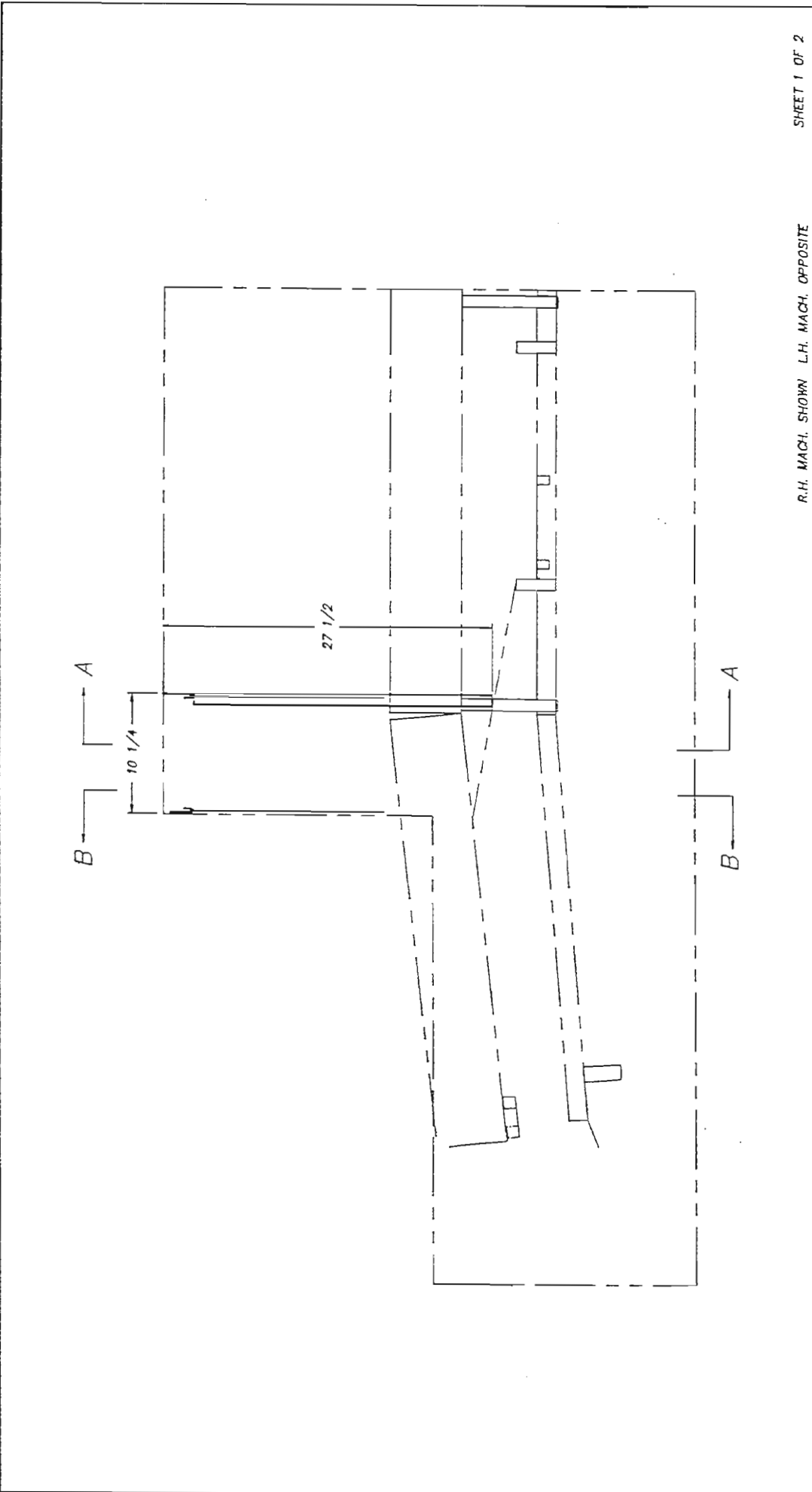

R.H. MACH. SHOWN L.H. MACH. OPPOSITE SHEET 1 OF 2

TOLERANCES		NEXT ASSY DWG. NO.	
FRACTIONS $\pm 1/64$		1390-10	
DECIMALS		RECD 1	
.XXX $\pm .005$		SCALE	USED ON
.XX $\pm .01$		AS NOTED	1-8
ANGLES $\pm 1/2^\circ$			CENTURY
UNLESS OTHERWISE SPECIFIED			DRNN/DATE
REV	ECH NO	DATE	PC
A	1004	4.25.04	
FILE: PARTS\1390-10			

insinger
Machine Company
Philadelphia, PA 19135
(215) 824-4800
FAX (215) 824-8866

ITEM	PART NO.	SIZE	DESCRIPTION	QTY.
1	1390-53-2	A	TOP BAFFLE	1
2	1390-55	A	SIDE BAFFLE	1
3	D-761B	A	CURTAIN ROD CLIP	4
4	D2-522-1	A	SPLASH GUARD CURTAIN	2

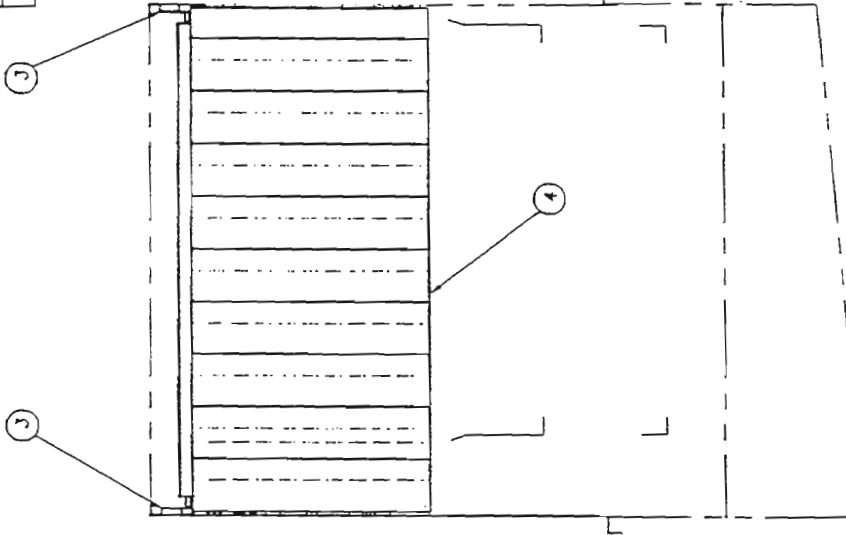

SECTION B-B

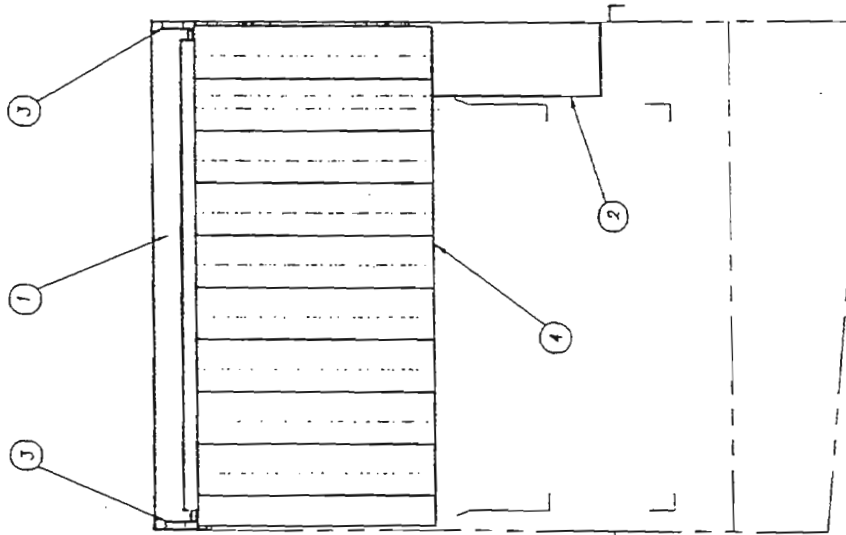

SECTION A-A

R.H. MACH. SHOW L.H. MACH. OPPOSITE

SHEET 2 OF 2

TOLERANCES	TITLE	REGD	SCALE	USED ON
FRACTIONS ±1/64	CURTAIN & BAFFLE INSTALLATION	1	1=8	CENTURY
DECIMALS .XXX ±.005	UNLOAD SECTION	1		DATE
.XX ±.01				
ANGLES ±1/2°				
UNLESS OTHERWISE SPECIFIED				
REV	ECH. NO.	DATE		
A	1004	4.25.04		
FILE: PARTS\1390-10				

NEXT ASSY	DWG. NO.	REGD	SCALE	USED ON
1390-1	1390-10	1	1=8	CENTURY
AS NOTED				
Philadelphia, PA 19135				
(215) 824-4000				
FAX (215) 624-8866				
4.2.93				

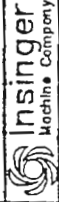

InSinger
Machine Company

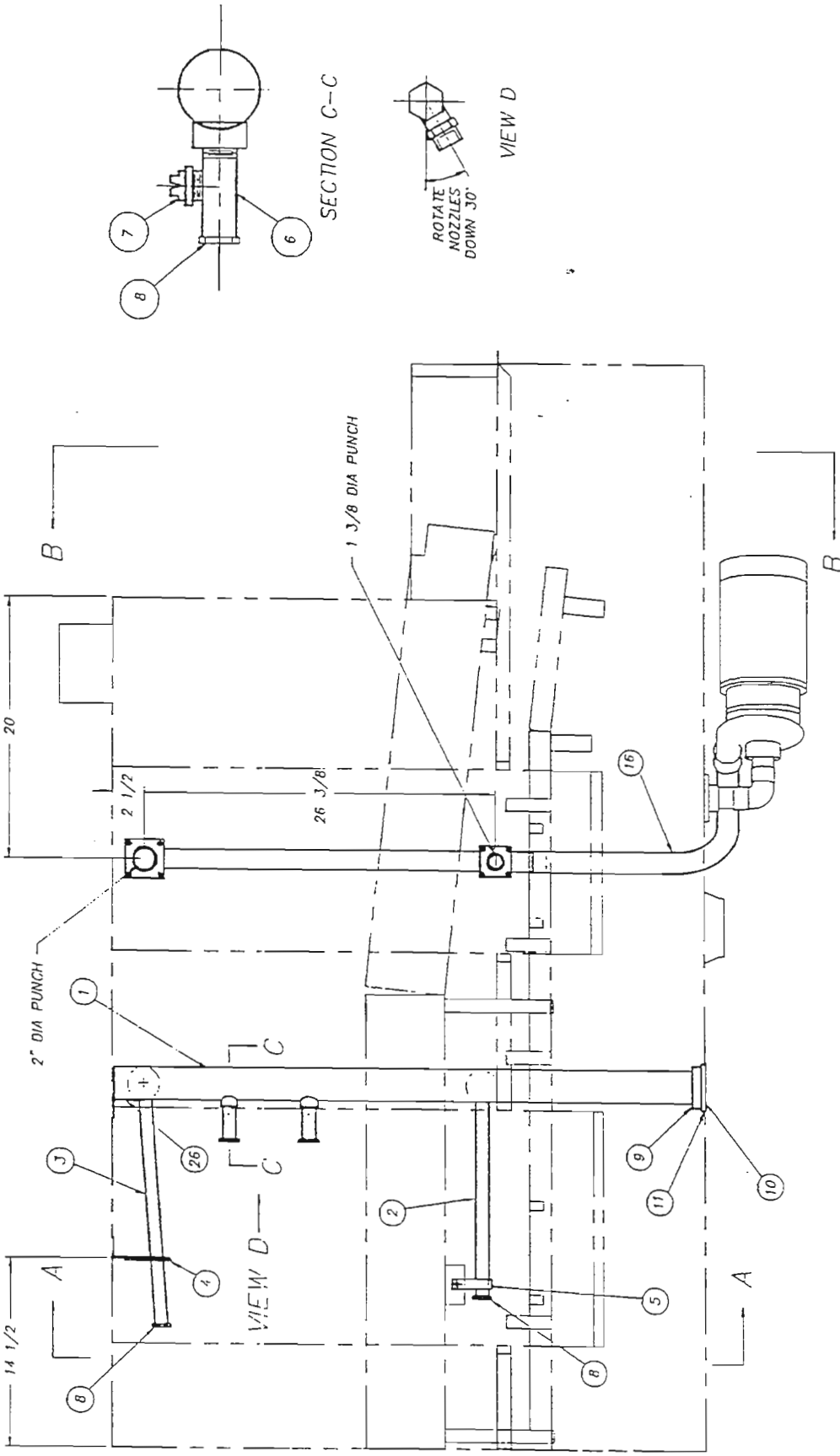

R.H. MACHINE SHOWN SHEET 1 OF 4

TITLE		DISCHARGE LINE ASSEMBLY		NEXT ASSY/DWG. NO.	
MATERIAL		LOAD SECTION		1390-1	
TOLERANCES		NOTED		SCALE	
FRACTIONS ±1/64		1=8		USED ON	
DECIMALS		.XXX ± .005		CENTURY	
.XX ± .01		UNLESS OTHERWISE SPECIFIED		1390-56	
ANGLES ±1/2°		REV		DATE	
100#4		A		3.23.84	
4.27.94		990		3.23.84	
FILE: PARTS 1390-56		REV		DATE	
		A		3.23.84	

insinger
 Machine Company
 Philadelphia, PA 19135
 (215) 624-4800
 FAX (215) 624-6866
 PC 4.5.93

ITEM	PART NO.	SIZE	DESCRIPTION	QTY.
1	1390-58	B	DISCHARGE TUBE-WASH	1
2	1390-33	B	MANIFOLD ASSEMBLY-LOWER	1
3	1390-34	B	MANIFOLD ASSEMBLY-UPPER	1
4	1372-17	A	LATCH ASSEMBLY-SPRAY PIPE	1
5	1390-59	A	CRADLE-SPRAY PIPE	1
6	1162-94	A	EXTENSION MANIFOLD	2
7	D2773	-	SPRAY NOZZLE	2
8	D2-554-J	A	PLUG 7/8-9 UNC-2A	9
9	D2-158	A	TANK FLANGE	1
10	D-514	A	GASKET	1
11	D3-511	-	CUPSEAL, PARKER #8406-0250-4180	1
12	D2-564	-	"O" RING (O1-032)	2
13	1390-63	A	NIPPLE	1
14	D2749	-	HOSE CLEAR FVC, 1 J/4 I.D. X 2 1/4 O.D. X 2 1/2 LG.	1
15	D2748	-	HOSE CLAMPS	2
16	1390-60	B	DISCHARGE TUBE WELDMENT	1
17	1182-70	A	GASKET-UPPER	1
18	1182-71	A	GASKET-LOWER	1
19	D580	-	"O" RING	1
20	D2-570	-	"O" RING	1
21	1390-64	B	LOWER SPRAY PIPE	1
22	1390-65	B	UPPER SPRAY PIPE	1
23	D2272	-	SPRAY NOZZLE	4
24	D2712	-	SPRAY NOZZLE	4
25	D-91	A	THUMBSCREW	2
26	1169-96	A	SUPPORT INSTALLATION	1

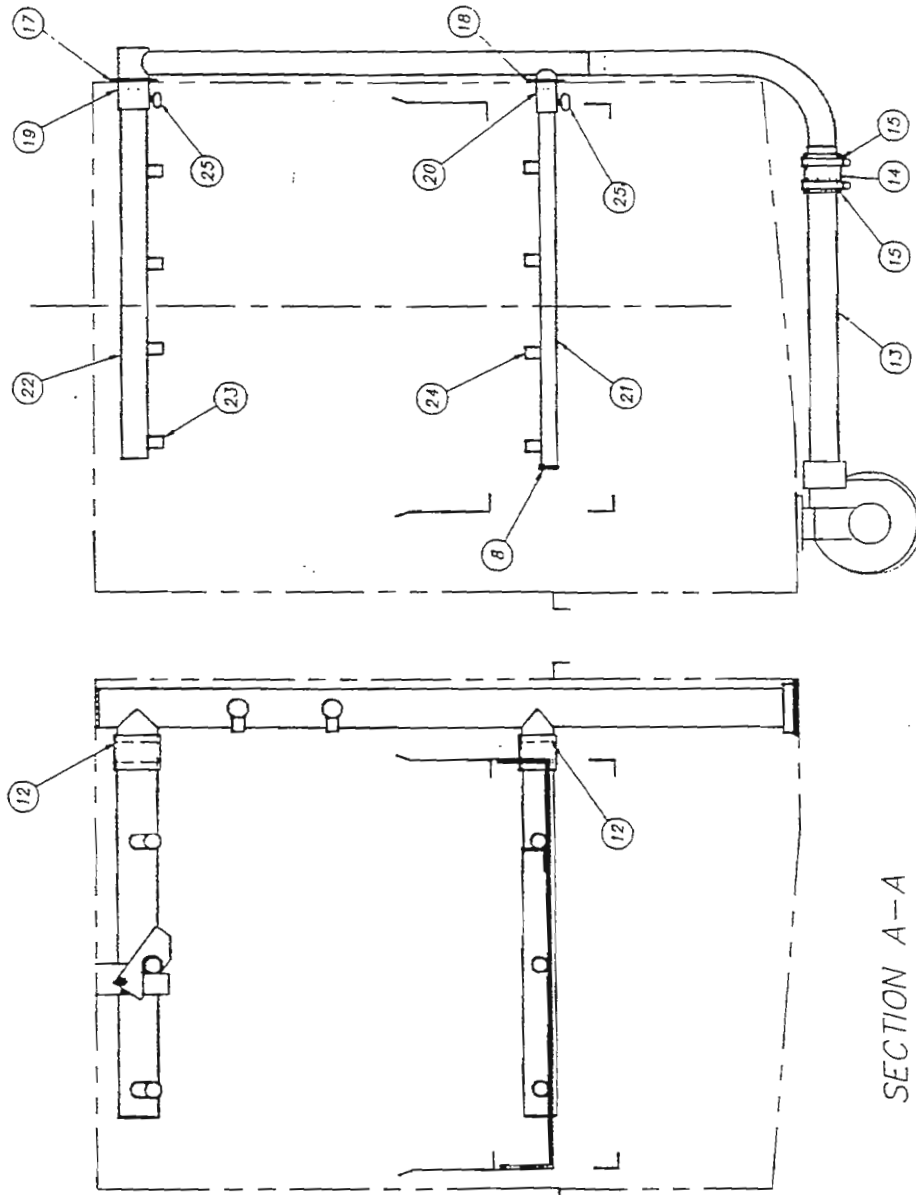

SECTION A-A

SECTION B-B

R.H. MACHINE SHOWN

SHEET 2 OF 4

TOLERANCES	±1/64	FRACCTIONS	±1/64
DECIMALS	.XXX ± .005	DECIMALS	.XX ± .01
ANGLES	±1/2°	UNLESS OTHERWISE SPECIFIED	

REV	ECN NO	DATE	FILE: PARTS \ 1390-56
B	1008	4.27.94	
A	990	3.23.94	

TITLE	DISCHARGE LINE ASSEMBLY	REV	1
LOAD SECTION		SCALE	1"=8'
NOTED		USED ON	1390-56

NEXT ASSY BWR. NO.
1390-1

DRWT/DATE
PC 4.3.93

Philadelphia, PA 19135
(215) 824-4800
FAX (215) 824-6968

Insinger
Machine Company

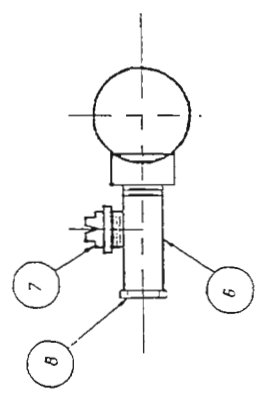
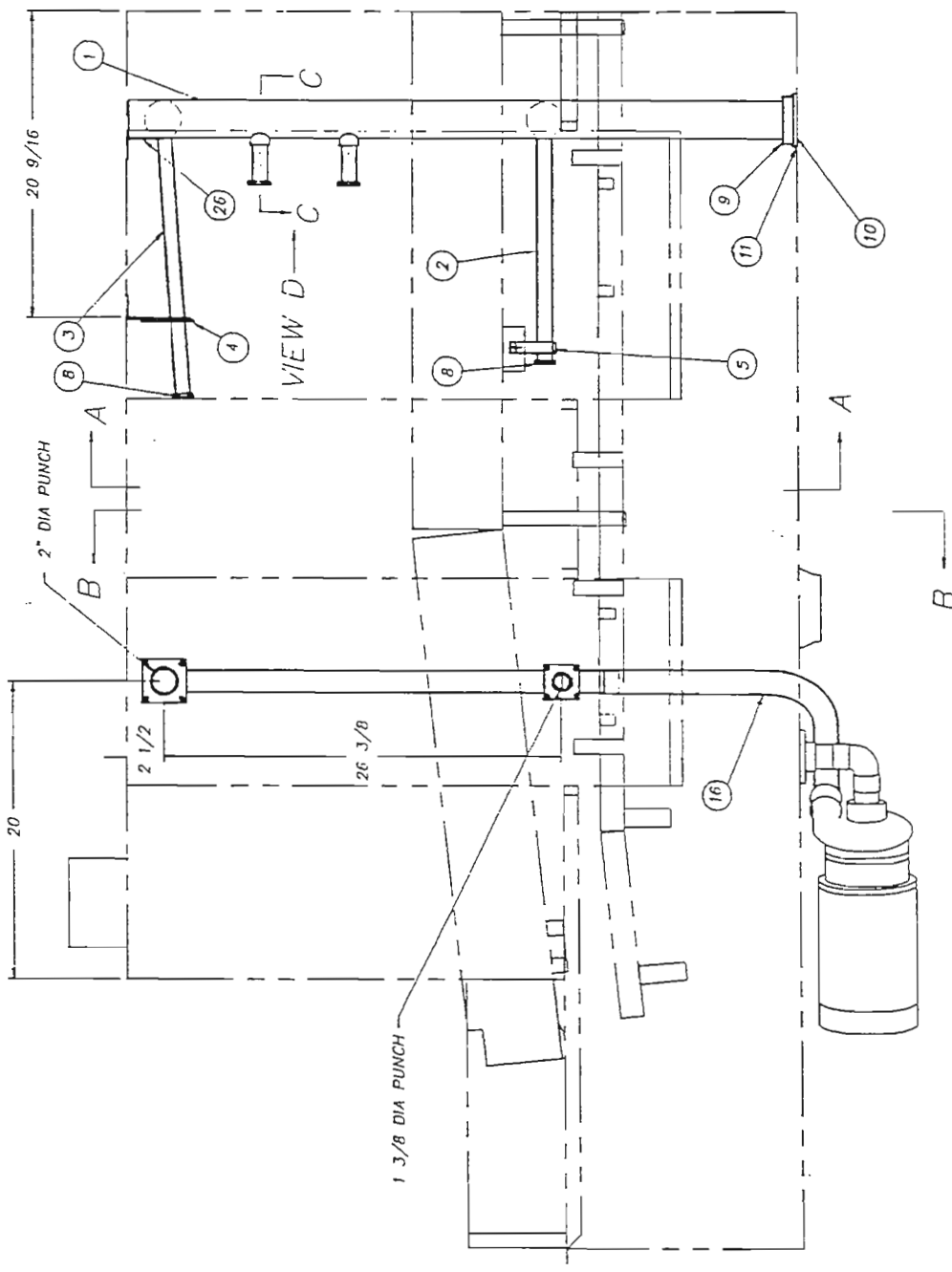

SECTION C--C

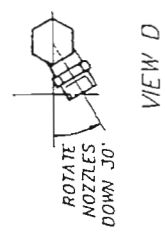

VIEW D

L.H. MACHINE SHOWN SHEET 3 OF 4

TITLE		DISCHARGE LINE ASSEMBLY		NEXT ASSY DWG. NO.	
MATERIAL		NOTED		1390-1	
TOLERANCES:		FRACTIONS ±1/64		1390-56	
		DECIMALS .XXX ± .005		SCALE 1=8	
		.XX ± .01		USED ON CENTURY	
		ANGLES ±1/2°		DRAWN/DATE	
		UNLESS OTHERWISE SPECIFIED		PG 4.5.BJ	
REV		ECN NO.		DATE	
B		10014		4.27.94	
A		990		3.23.94	
FILE: PARTS\1390-56					

Philadelphia, PA 19135
 (215) 624-4800
 FAX (215) 624-6906

ITEM	PART NO.	SIZE	DESCRIPTION	QTY.
1	1390-58	B	DISCHARGE TUBE-WASH	1
2	1390-33	B	MANIFOLD ASSEMBLY-LOWER	1
3	1390-34	B	MANIFOLD ASSEMBLY-UPPER	1
4	1372-17	A	LATCH ASSEMBLY-SPRAY PIPE	1
5	1390-59	A	CRADLE-SPRAY PIPE	1
6	1162-94	A	EXTENSION MANIFOLD	2
7	D2773	-	SPRAY NOZZLE	2
8	D2-554-J	A	PLUG 7/8-9 UNC-2A	9
9	D2-158	A	TANK FLANGE	1
10	D-514	A	GASKET	1
11	DJ-511	-	CUPSEAL, PARKER #8406-0250-4180	1
12	D2-564	-	"O" RING (01-032)	2
13	1390-78	A	NIPPLE	1
14	D2749	-	HOSE CLEAR FVG, 1 3/4 I.D. X 2 1/4 O.D. X 2 1/2 LG.	1
15	D2748	-	HOSE CLAMPS	2
16	1390-60	B	DISCHARGE TUBE WELDMENT	1
17	1182-70	A	GASKET-UPPER	1
18	1182-71	A	GASKET-LOWER	1
19	D580	-	"O" RING	1
20	D2-570	-	"O" RING	1
21	1390-64	B	LOWER SPRAY PIPE	1
22	1390-65	B	UPPER SPRAY PIPE	1
23	D2272	-	SPRAY NOZZLE	4
24	D2712	-	SPRAY NOZZLE	4
25	D-91	A	THUMBSCREW	2
26	1169-96	A	SUPPORT INSTALLATION	1

ITEM	PART NO.	SIZE	DESCRIPTION	QTY.
27	DJ17A-HJ-H1	-	ADAPTER 1 1/2C X 1 1/2 FIPS	1
28	DJ15A-HJ-H3	-	ELL 45° 1 1/2C	2
29	D207A-B12-26	-	COPPER TUBING 1 1/2 X 6 1/2 LG	1
30	DJ17A-HJ-H2	-	ADAPTER 1 1/2C X 1 1/2 MIPS	1

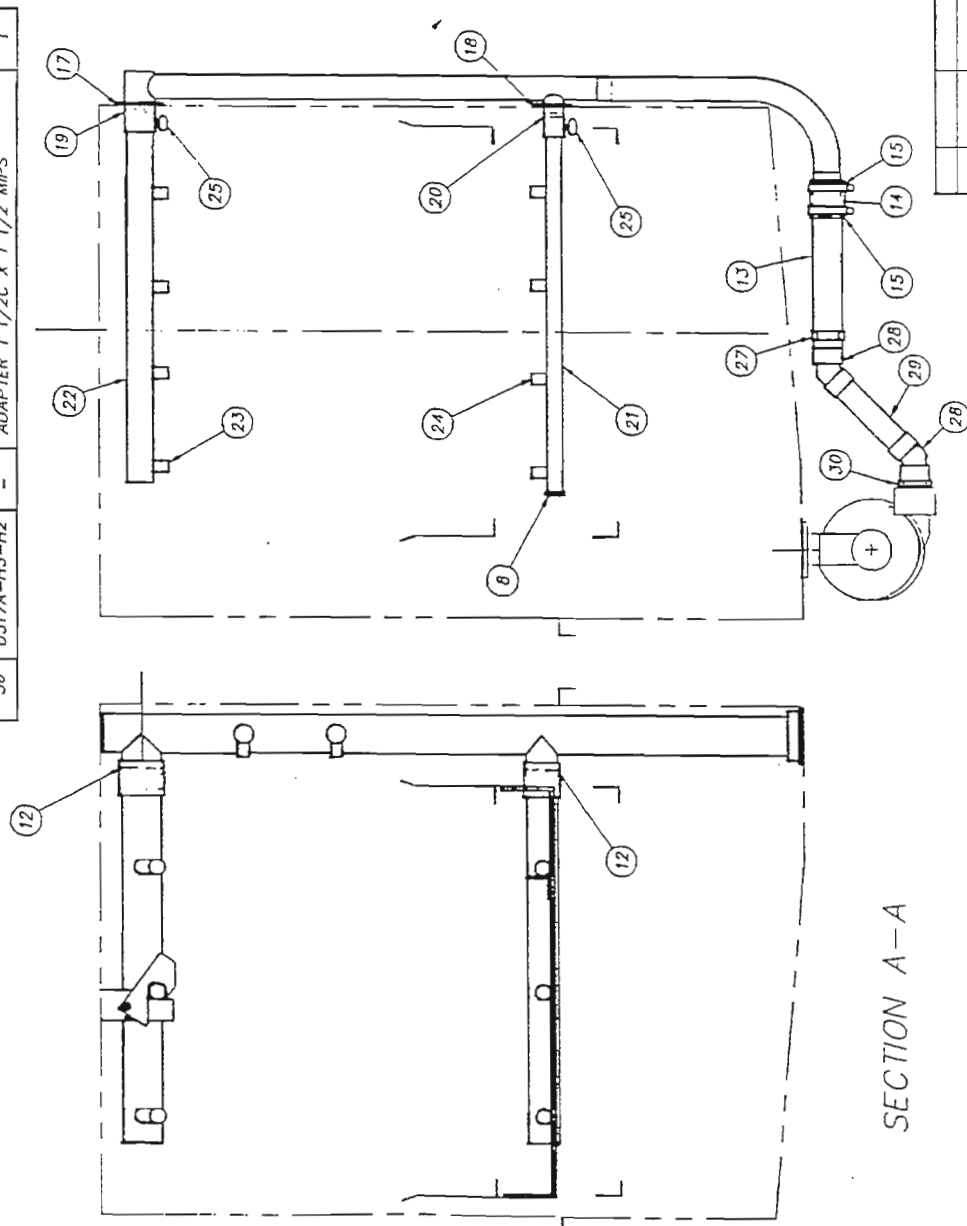

SECTION A-A

SECTION B-B

L.H. MACHINE SHOWN

SHEET 4 OF 4

TOLERANCES:	FRACTIONS ±1/64	DECIMALS .005	XX ±.01	ANGLES ±1/2°	UNLESS OTHERWISE SPECIFIED
REV	1004	4.27.94	DATE	1.30.56	FILE:PARTS\1300-56
REV	990	3.23.94	DATE		
REV	1004	4.27.94	DATE	1.30.56	FILE:PARTS\1300-56
TITLE	DISCHARGE LINE ASSEMBLY		LOAD SECTION	NOTED	SCALE 1=8
WATL	NEXT ASSY DWG. NO. 1390-1		REQ'D 1	USED ON 1390-56	CENTURY
INSINGER Machine Company			Philadelphia, PA 19135		DIRTY/DATE
			(215) 624-4800		PC
			FAX (215) 624-8068		4.5.03

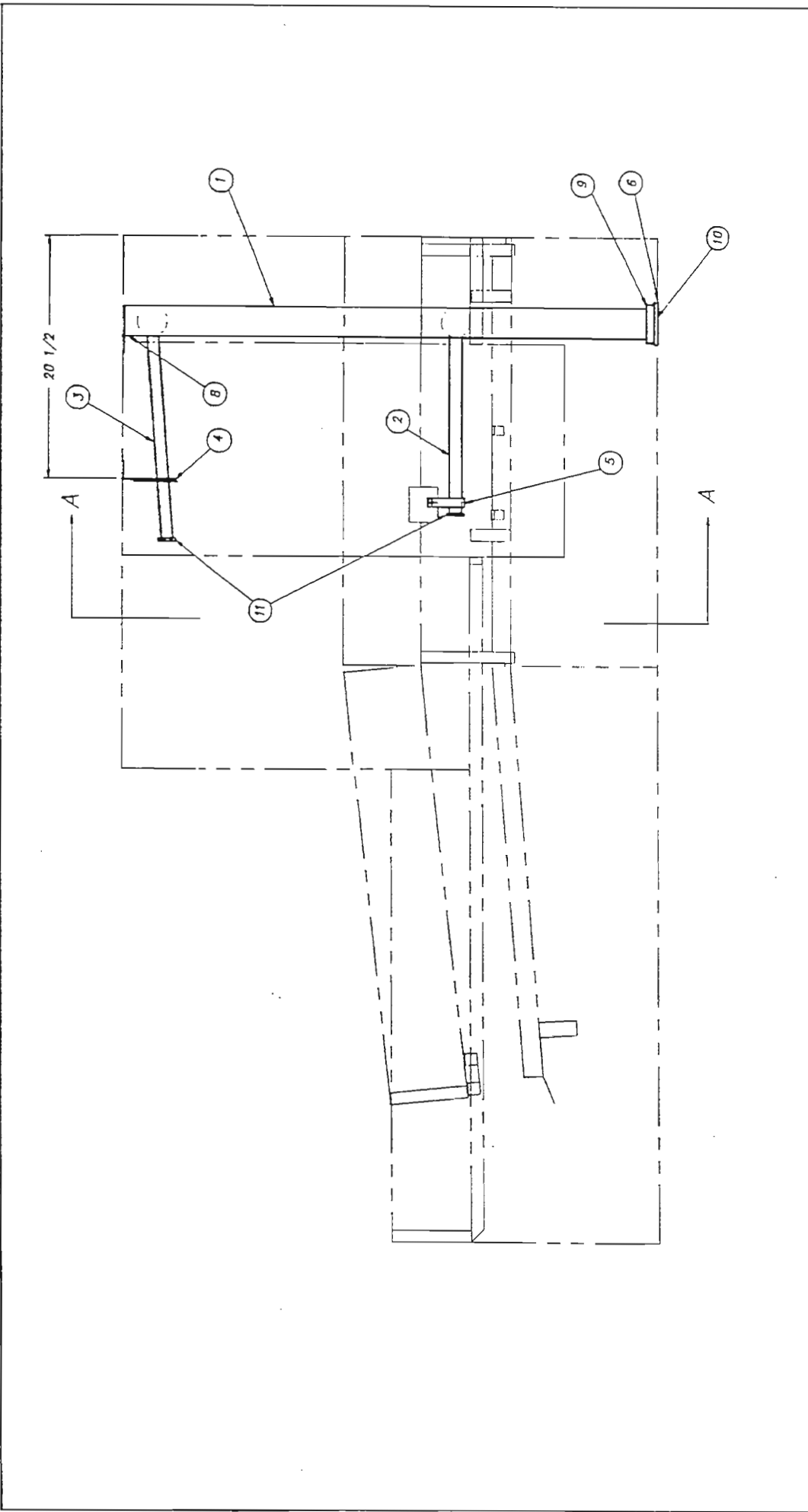

R.H. MACHINE SHOW		SHEET 1 OF 3	
TOLERANCES	FRACTIONS ±1/4	REV	ECN NO
	DECIMALS	1390-1	DATE
	.XXX ± .005	RECD 1	1390-57
	.XX ± .01	SCALE 1=8	USED ON
	ANGLES ±1/2°	AS NOTED	CENTURY
	UNLESS OTHERWISE SPECIFIED	UNLOAD SECTION	DRWR/DATE
		PHILADELPHIA, PA 19135	PC
		(215) 824-4800	
		FAX (215) 824-8888	4.12.93

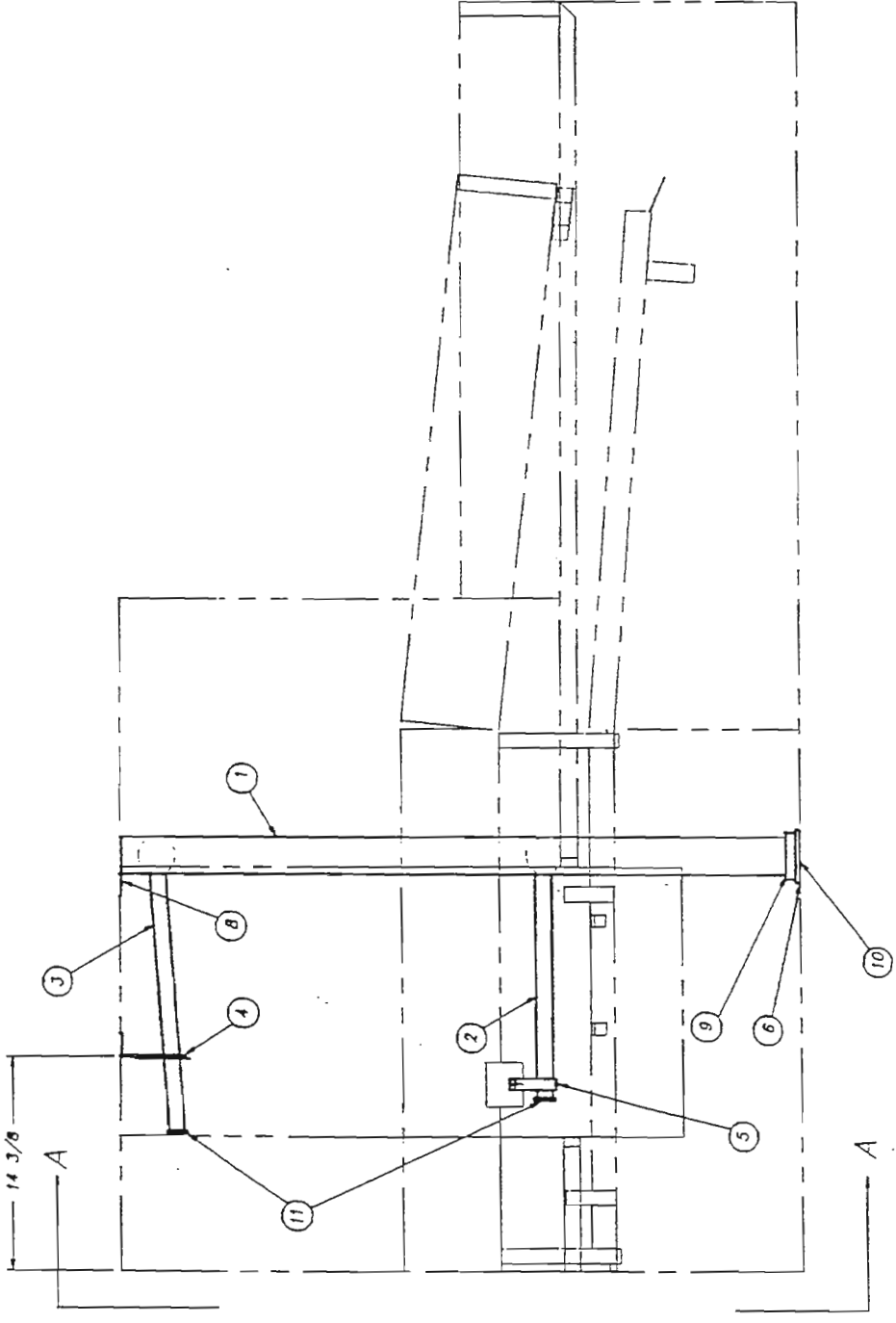

L.H. MACHINE SHOWN		SHEET 2 OF 3	
TOLERANCES	FRACTIONS ±1/64	NEXT ASSY	DWG. NO.
	DECIMALS .XXX ± .005	1390-1	1390-57
	.XX ± .01	REQD	1
	ANGLES ±1/2°	SCALE	USED ON
	UNLESS OTHERWISE SPECIFIED	1/4" = 1"	CENTURY
REV	ECH NO	DATE	
FILE: PARTS\1390-57			
TITLE DISCHARGE LINE ASSEMBLY UNLOAD SECTION		PHILADELPHIA, PA 19135	
UNL		(215) 624-4800	
AS NOTED		FAX (215) 624-8888	
 Insinger Machine Company		DRWN/DATE PC 4.12.93	

ITEM	PART NO.	SIZE	DESCRIPTION	QTY.
1	1380-67	B	DISCHARGE TUBE-RINSE	1
2	1390-33	B	MANIFOLD ASSEMBLY-LOWER	1
3	1380-34	B	MANIFOLD ASSEMBLY-UPPER	1
4	1372-17	A	LATCH ASSEMBLY-SPRAY PIPE	1
5	1380-59	A	CRADLE-SPRAY PIPE	1
6	D3-511	-	CUP SEAL PARKER#8408-0250-4180	1
7	D2-664	-	"O" RING (O1-032)	2
8	1189-96	A	SUPPORT INSTALLATION	1
9	D2-158	A	TANK FLANGE	1
10	D-514	A	GASKET	1
11	D2-554-J	A	PLUG 7/8-9 UNC-2A	8

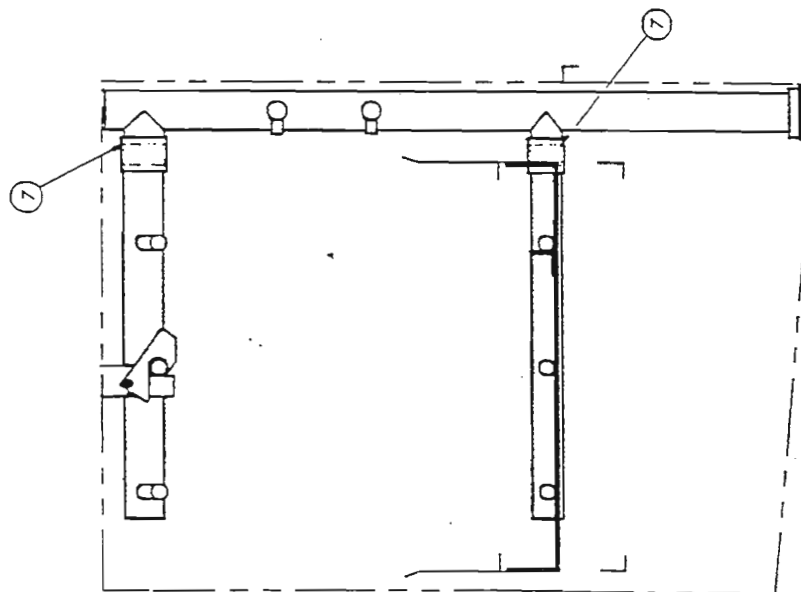

SECTION A-A

TOLERANCES		TITLE		NEXT ASSY ORG. NO.	
FRACTIONS ±1/64		DISCHARGE LINE ASSEMBLY	1380-1	REQ'D	1390-57
DECIMALS		UNLOAD SECTION			
XXX ±.005					
XXX ±.01					
ANGLES ±1/2°					
UNLESS OTHERWISE SPECIFIED					
REV	ECN NO.	DATE	SCALE		
FILE:PARTS\1380-57			1=8	USED ON	
			CENTURY		
			DRAWN/DATE		
			PO		
			4.12.03		

SHEET 3 OF 3

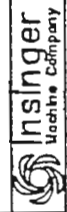

Insinger
Machine Company

Philadelphia, PA 19135
(215) 824-4800
FAX (215) 824-8888

ITEM	PART NO.	SIZE	DESCRIPTION	QTY.
1	1390-69	B	FINAL RINSE INSIDE FITTING	1
2	975-100	A	BRACKET	2
3	0309C-E7-3C	-	WELD STUD 10-32 X 3/8	2
4	0312C-E7-5	-	LOCKNUT 10-32	2
5	0314F-EA-12	-	NIPPLE 3/4 P.S X 1 1/2 AT	1
6	0320F-E1	-	LOCKNUT 3/4 P.S	1
7	0320A-E3101	-	TEE 3/4 P.S X 3/4C X 1/2 IP	1
8	0320F-D2-A	-	PIPE PLUG 1/2 P.S	1
9	03-603	A	ADAPTER	2
10	02-394	-	1/2" RING	2
11	SK-3618	A	SPRAY PIPE	1
12	0-2266	-	SPRAY NOZZLES 1/8 P.S	4
13	02-554-2	A	PLUG 3/4-10 UNC-2A	2
14	0320F-E7-01	-	HEX RED 3/8 P.S X 1/2 P.P.S	1
15	0207A-06-22	-	COP TUBE 3/4 CTS X 5 1/2	1
16	0-2243	-	VACUUM BREAKER 3/4 P.S	1
17	0314F-E3-16	-	NIPPLE 3/4 P.S X 2	1
18	0316F-E3-E1	-	90° ELL 3/4 C X 3/4 P.P.S	1
19	0317A-E3-E2	-	ADAPTER 3/4 P.P.S X 3/4 C	1
20	0-2397	-	SOLENOID (WATER) 3/4 P.S	1
21	0316F-EC-00	-	CLOSE NIPPLE 3/4 P.S	2
22	0320F-E1E1E1	-	TEE 3/4 P.S	1
23	0320F-E2-81	-	HEX RED 3/4 P.P.S X 1/4 P.P.S	1
24	0-2497	-	PETCOCK 1/4 P.S	1
25	SK-1433	A	PRESSURE GAUGE 1/4 P.S	1
26	1100-283	B	SPRAY PIPE	1
27	02701	-	SPRAY NOZZLE	8
28	0312C-E7-7	-	WRENCHUT #10-32	2
29	0309C-E7-6B	-	RO NO SDR #10-32 X 3/4	2
30	1390-68	A	RETAINER	1
31	1390-69	A	COLLAR	1
32	0309C-0C-5C	-	WELD STUD 1/4-20 X 5/8 LG.	2
33	0312C-0C-5	-	LOCKNUT 1/4-20	1
34	02-651	-	NANO 1/4-20	1

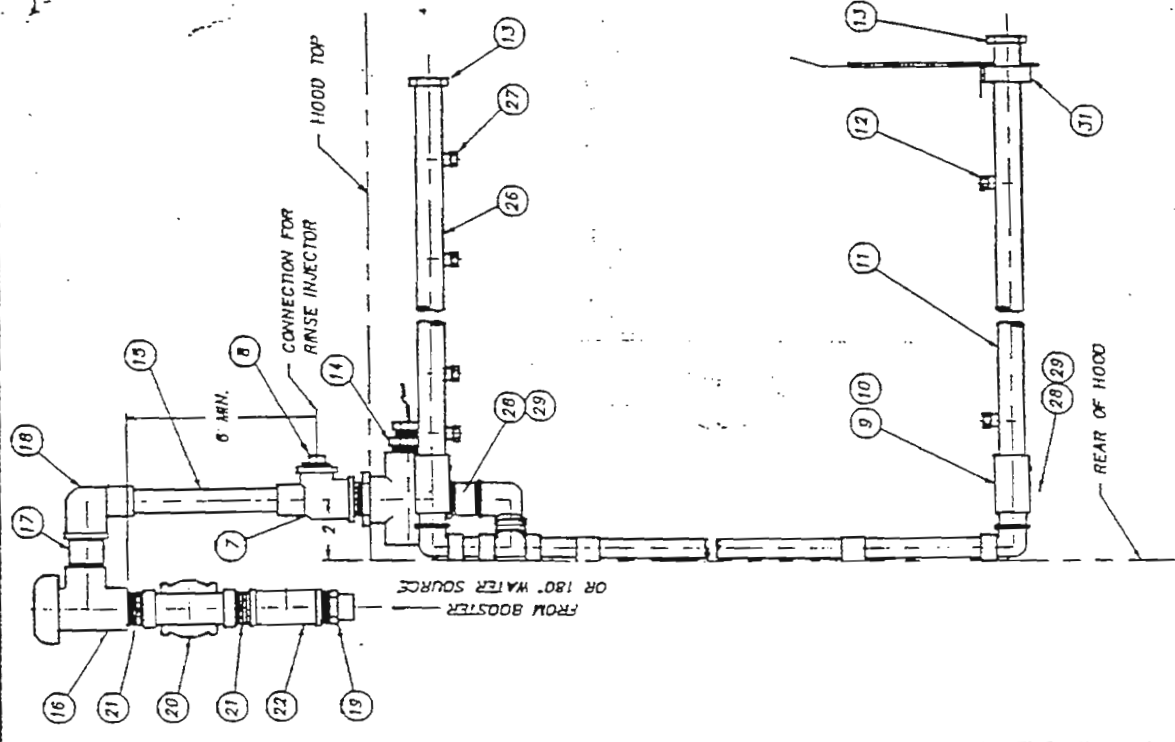
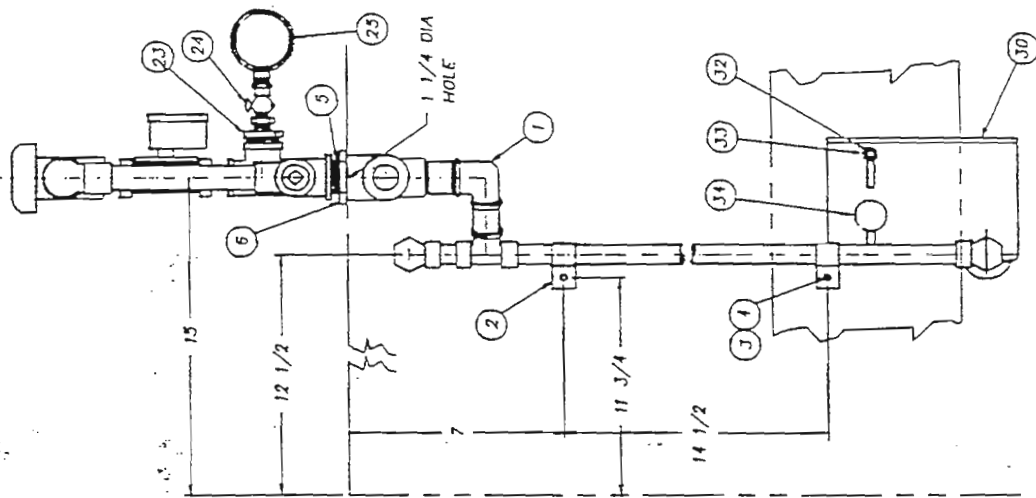

FRONT VIEW
AT RINSE END

TITLE	FINAL RINSE ASSEMBLY	NOTED
DATE	1390-68	SCALE 1=4
REV	ECN NO	DATE
8	1004	5.16.94
A	976	1.14.94
TOLERANCES		
FRACTIONS ±1/64		
DECIMALS .XXX ±.01		
.XXX ±.01		
ANGLES ±1/2°		
UNLESS OTHERWISE SPECIFIED		

FILE/PARTS	1390-68
REV	ECN NO
DATE	1.14.94
5.16.94	1004
DECIMALS	±.01
FRACTIONS	±1/64

R.H. MACH. SHOWN L.H. MACH. OPPOSITE

NEXT ASSY DWG. NO. 1390-68

USED ON CENTURY

DRWN/DATE

PG 4.6.93

1390-68

SCALE 1=4

NOTED

FINAL RINSE ASSEMBLY

DATE 1.14.94

REV 976

1004

5.16.94

FRONT VIEW AT RINSE END

REAR OF HOOD

FROM BOOSTER OR 180° WATER SOURCE

CONNECTION FOR RINSE INJECTOR

HOOD TOP

6" HORN



Hsinger Machine Company

PHILADELPHIA, PA 19135

(215) 874-4800

FAX (215) 874-8866

ITEM	PART NO.	SIZE	DESCRIPTION	QTY.
1	1100-289	B	CONVEYOR OVERLOAD SHUTOFF	1
2	1100-117	B	DRIVE SHAFT ASSY	1
3	-	-	MOTOR BALDOR M3108 ODP	1
4	D-2344A	-	REDUCER BOND 262B 64:1	1
5	D-2527	-	PULLEY 7.95 O.D.	1
6	818-16	A	PULLEY	1
7	D2-582	-	"V" BELT 4L450	1
8	1100-123	B	STOP BAR ASSY & LOCATION	1
9	1390-80	A	COVER, MECHANISM GUARD	1
10	D2-843	A	BRACKET, MECHANISM GUARD	2
11	1390-89	A	SHIM	2

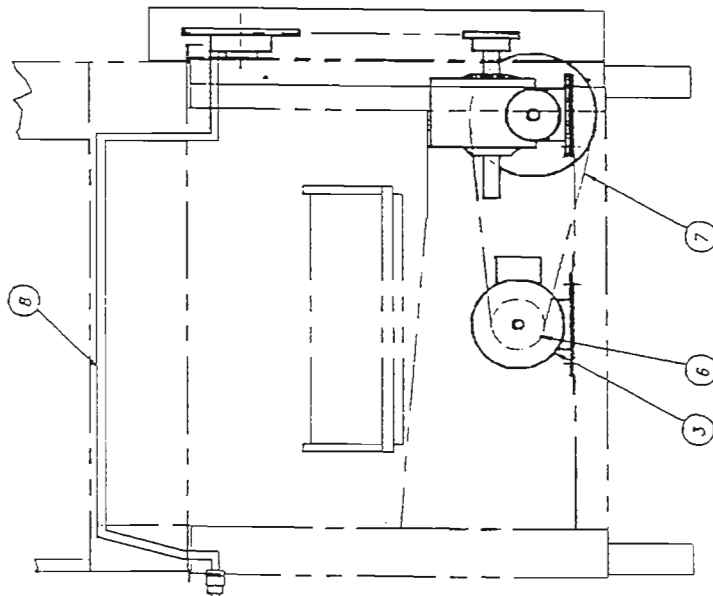
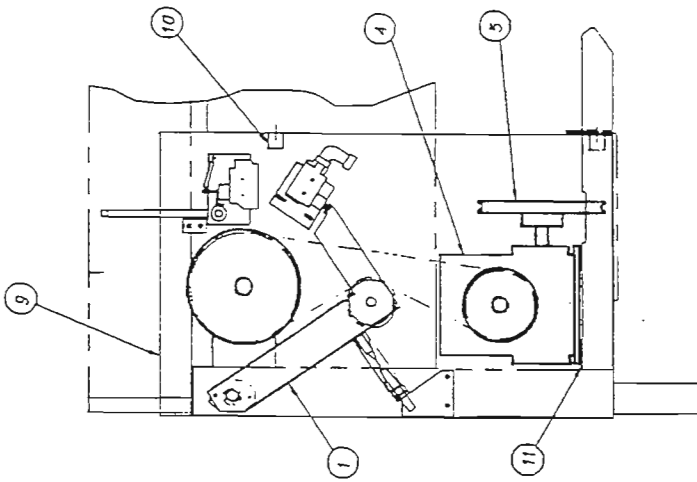
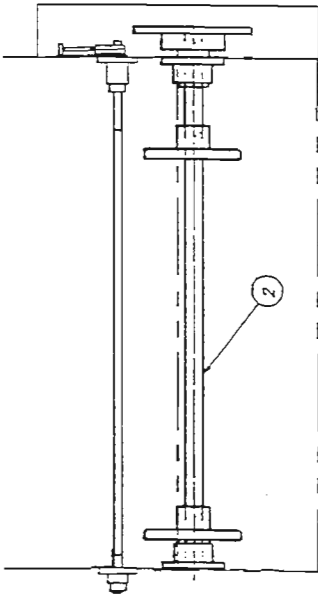

R.H. SHOWN L.H. OPPOSITE

TOLERANCES:	FRACCTIONS ±1/64	DECIMALS	.XXX ± .005	.XX ± .01	ANGLES ±1/2°	UNLESS OTHERWISE SPECIFIED
REV	ECN NO	DATE	FILE:PARTS\1390-72			
TITLE		CONVEYOR DRIVE ASSEMBLY		NEXT ASSY DWG. NO. 1390-1		
SCALE		AS NOTED		1390-72		
DRAWN		L.H. SHOWN		USED ON		
CENTURY		1980		CENTURY		
DATE		4.15.83		DRAWN/DATE		
PC		PC		FAX (215) 674-6866		
Machine Company		Philadelphia, PA 19135		(215) 674-4800		
insinger		Machine Company		FAX (215) 674-6866		

UNLOAD END

ITEM	PART NO.	SIZE	DESCRIPTION	QTY.
1	0326F-01	-	LOCKWUT 1/2 IPS	J
2	0314F-0L-S2	-	NIPPLE 1/2 IPS X 6 1/2 L.O.E.	J
3	0316F-01-02	-	90° STREET ELL 1/2 IPS	6
4	D-2241	-	VACUUM BREAKER 1/2 IPS	J
5	0314F-0C-00	-	CLOSE NIPPLE 1/2 IPS	6
6	D-2606	-	SOLENOID VALVE 1/2 IPS 24V	J
7	0320F-E1E1D1	-	TEE 3/4IPS X 3/4IPS X 1/2FIPS	1
8	0317A-EJ-E2	-	ADAPTER 3/4 C X 3/4 MIPS	2
9	0320F-E1D1D1	-	TEE 3/4IPS X 1/2FIPS X 1/2FIPS	1
10	0328F-02-A	-	PIPE PLUG 1/2 IPS	1
11	957-80	A	BRACKET	J
12	D207A-88-88	-	COPPER TUBING 3/4CTS X 17	2
13	0315A-D1-01	-	45° 1/2 FIPS X 1/2 FIPS	2
14	0318A-EJ-E	-	UNION J/4C	1

ITEM	PART NO.	SIZE	DESCRIPTION	QTY.
15	0317A-03-04	-	ADAPTER 1/2 C X 1/2 MIPS	2
16	D207A-84-80	-	COPPER TUBING 1/2 CTS X 20 LG.	1
17	0320F-01D1D1	-	TEE 1/2 IPS	1
18	0314F-EC-00	-	CLOSE NIPPLE 3/4 IPS	1
19	D-2482	-	"Y" STRAINER 3/4 IPS	1
20	0328F-01	-	CAP 1/2 IPS	1

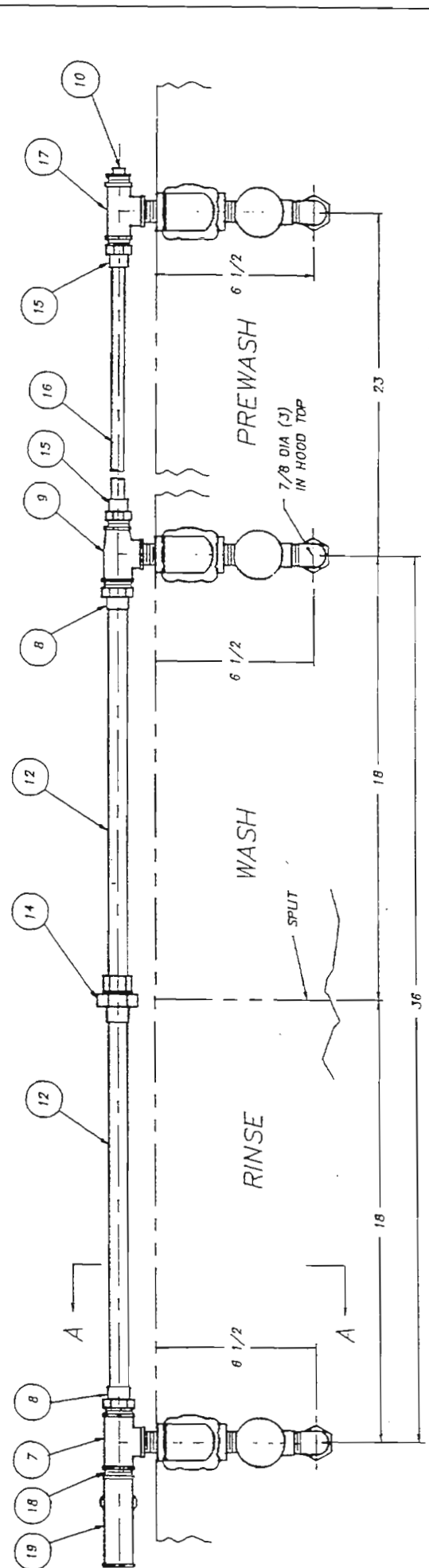
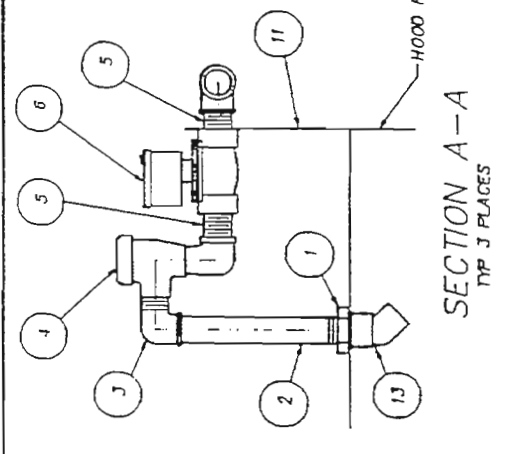

TOLERANCES		TITLE		SCALE		USED ON	
FRACTIONS ±1/64	DECIMALS ±.005	AUTO TANK FILL ASSEMBLY		1-4		CENTURY	
XXX ±.01	.XX ±.01	WASH & RINSE		1-4		DRWN/DATE	
ANGLES ±1/2°	UNLESS OTHERWISE SPECIFIED	NOTED		1-4		PC	
REV	EDN NO	DATE		FILE: PARTS\1390-71		R.H. SHOWN L.H. OPPOSITE	
A	1001	4.25.04		NEXT ASSY DWG. NO. 1390-71		1390-71	

Insinger
 Machine Company
 Philadelphia, PA 19135
 (215) 624-4800
 FAX (215) 624-8888

ITEM	PART NO.	DESCRIPTION	QTY.
1	1100-285	ADJUSTABLE SPRING STOP	1
2	1100-309	SHIM	1
3	D312C-LC-2	1/2-13 HEX NUT	1
4	D312C-LC-1	1/2-13 JAM NUT	1
5	1100-286	ATC PIVOT CUP	1
6	D2-525	1/8 THK SPACER	3
7	D470A	1/16 THK WASHER	1
8	1100-287	ATC ARM WELDMENT	1
9	1100-288	MICROSWITCH BRACKET	1
10	D351	SPRING	1
11	D2215A	MICROSWITCH	1
12	1100-310	IDLER SPROCKET	1
13	D2714	60B18-F1 SPROCKET	1
14	D2760	60B13-F1 SPROCKET	1
15	D308C-60	ROLLER CHAIN, 48 3/4 LG	1
16	D308C-60	ROLLER CHAIN, TBD LG	1
17	D308C-60	ROLLER CHAIN, 49" LG.	1
18	D308C-60CL	ROLLER CHAIN CONN. LINK	1
19	D311-22	S/S COTTER PIN, 1/8 x 1 1/4	2
20	D309C-GC-5	1/4-20 x 5/8 LG VELD STUD	2
21	-	-	-
22	D-2333	60B36-F1 1/8 SPROCKET	1
23	D2-146	60B29-F1 1/8 SPROCKET	1
24	D2761	60B30-F1 1/8 SPROCKET	1
25	1100-311	ADJUSTABLE SPRING STOP	1
26	1100-312	SHIM	1
27	-	-	-
28	-	-	-
29	-	-	-

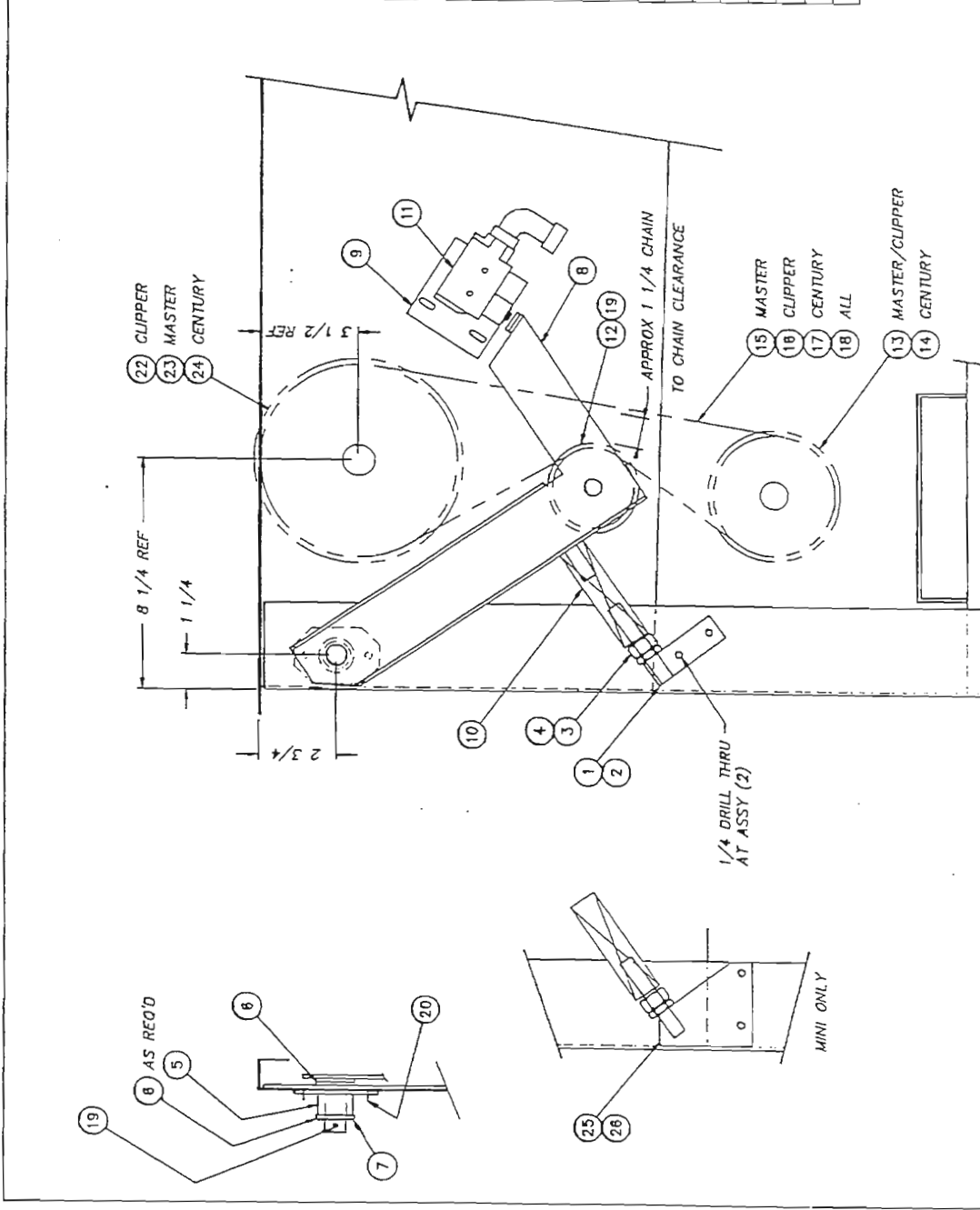

RIGHT HAND SHOWN LEFT HAND OPPOSITE
DRAWN TO SCALE FOR MASTER MACHINE

TOLERANCES	TITLE	CONVEYOR OVERLOAD	NEXT ASSY/DWG. NO.
FRACTIONS ±1/64	REG'D	SHUTOFF ASSEMBLY	1100-289
DECIMALS .XXX ±.005	MATL	SCALE	USED ON
.XX ±.01		1=4	CUP/MASTER
ANGLES ±1/2°			DRWN/DATE
UNLESS OTHERWISE SPECIFIED			JRS 4.15.91
REV	ECH NO	DATE	
A	560		
B	851	3.12.93	
C	929	8.26.93	
FILE: PARTS\1100-289			

Insinger Philadelphia, PA 19135
 Mechth Company (215) 624-4800
 FAX (215) 624-6966

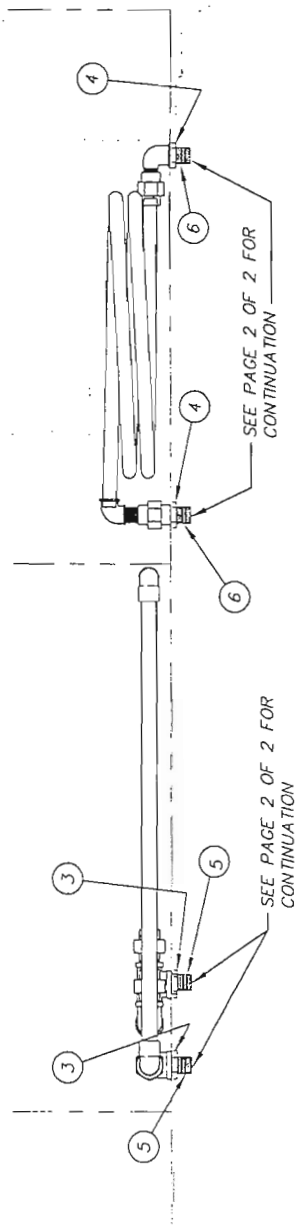
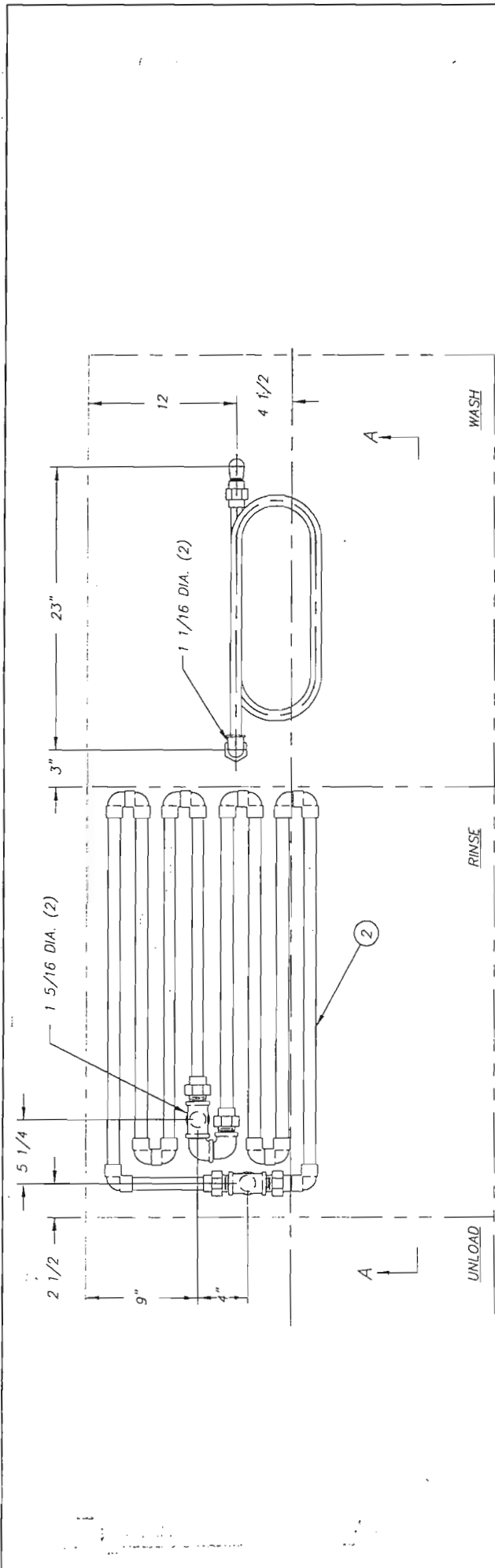

R.H. SHOWN - L.H. OPPOSITE

TOLERANCES	TITLE	NEXT ASSY DWG. NO.	SHEET 1 OF 3
FRACTIONS ±1/64	STEAM PIPING	1390-1	
DECIMALS	WASH & RINSE TANKS	RECD 1	1390-74
.XXX ± .005	MATL	SCALE	USED ON
.XX ± .01	AS NOTED	I=B	CENTURY
ANGLES ±1/2°			DRWN/DATE
UNLESS OTHERWISE SPECIFIED			PC
			4.26.93

VIEW A - A

Insinger
Machine Company
Philadelphia, PA 19135
(215) 624-4800
FAX (215) 624-6966

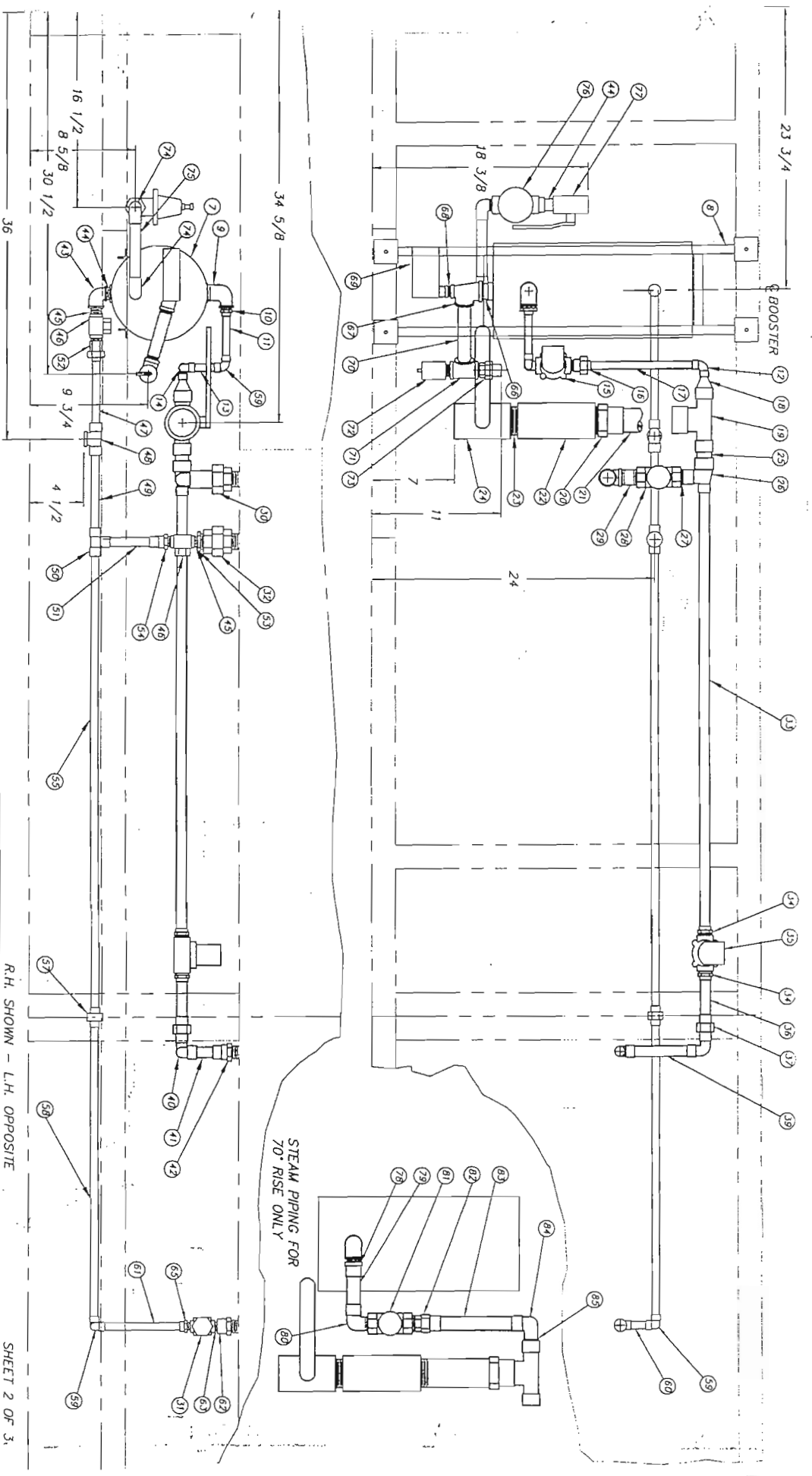

R.H. SHOWN - L.H. OPPOSITE

SHEET 2 OF 3

TOLERANCES		TITLE	
FRACTIONS 1/64		STEAM PIPING	
DECIMALS .005		WASH & RINSE TANKS	
XXX ± .005		MATERIAL	
ANGLE ± 01/2°		AS NOTED	
UNLESS OTHERWISE SPECIFIED		SCALE 1=8	
REV	ECN NO	DATE	USED ON
A	979	1.17.94	CENTURY
FILE: PARTS \1390-74			DRWN/DATE
			PG 4.26.93

Insinger
Machine Company

Philadelphia, PA 19135
(215) 624-4800
FAX (215) 674-6966

ITEM	PART NO.	DESCRIPTION	QTY.	ITEM	PART NO.	DESCRIPTION	QTY.	ITEM	PART NO.	DESCRIPTION	QTY.
61	D207A-B4-29	COPPER TUBING 1/2 CTS X 7 1/4	1	31	D2102	STEAM TRAP 3/8 IPS	1	1	1100-84	STEAM COIL - WASH	1
62	D320F-E1-C1	RED COUPLING 3/4 FIPS X 3/8 FIPS	1	32	D318F-F1-F1	UNION 1" FIPS X 1" FIPS	1	2	9019-01	STEAM COIL - RINSE	1
63	D314F-CC-00	NIPPLE CLOSE 3/8 IPS	-1	33	D207A-B6-152	COPPER TUBING 3/4 CTS X 3/8	1	3	D326F-F1	LOCKNUT 1" IPS	2
64	-	-	-	34	D317A-E3-E2	ADAPTER 3/4 C X 3/4 MIPS	2	4	D326F-E1	LOCKNUT 3/4" IPS	2
65	D317A-D3-C2	ADAPTER 1/2 C X 3/8 MIPS	1	35	D2595	SOLENOID VALVE 3/4 IPS	1	5	D314F-FA-16	NIPPLE 1"IPS X 2" ALL THD.	2
66	D314F-FC-00	NIPPLE CLOSE 1" IPS	1	36	D207A-B6-18	COPPER TUBING 3/4 CTS X 4 1/2	1	6	D314F-EA-14	NIPPLE 3/4 IPS X 1 3/4 ALL THD.	2
67	D320F-F1D1E1	TEE 1" FIPS X 1/2 FIPS X 3/4 FIPS	1	37	D319A-E3-E3	UNION ELL 3/4 C X 3/4 C	1	7	D 2100	STEAM BOOSTER (1-2) (SEE NOTE #1)	1
68	D322F-D2-C1	HEX RED 1/2 MIPS X 3/8 FIPS	1	38	-	-	-	8	1390-90	BOOSTER SUPPORT	1
69	D2396	THERMOSTAT (SEE NOTE #2)	1	39	D207A-B6-24	COPPER TUBING 3/4 CTS X 6	1	9	D316F-F2-F1	90° STREET ELL 1" MIPS X 1" FIPS	1
70	D314A-E3-A3	NIPPLE 3/4 IPS X 5 3/8	1	40	D316A-E3-E3	90° ELBOW 3/4 C X 3/4 C	1	10	D317A-D3-F2	ADAPTER 1/2 C X 1 MIPS	1
71	D320F-E1E1E1	TEE 3/4 IPS	1	41	D207A-B6-14	COPPER TUBING 3/4 CTS X 3 1/4	1	11	D207A-B4-17	COPPER TUBING 1/2 CTS X 4 1/4	1
72	D2507	PRESSURE RELIEF VALVE 3/4 IPS	1	42	D317A-E3-E1	ADAPTER 3/4 C X 3/4 FIPS	1	12	D316A-D4-D3	90° STREET ELL 1/2 FTG C 1/2 C	1
73	D318A-E3-E2	UNION 3/4 C X 3/4 MIPS	1	43	D316F-E2-E1	90° RED ELL 3/4 FIPS X 1/2 FIPS	1	13	D207A-B4-10	COPPER TUBING 1/2 CTS X 2 1/2	1
74	D316A-E3-E2	90° ELBOW 3/4 C X 3/4 MIPS	2	44	D314F-EC-00	NIPPLE CLOSE 3/4 IPS	2	14	D316A-D3-D2	90° ELBOW 1/2 C X 1/2 MIPS	1
75	D207A-B6-24	COPPER TUBING 3/4 CTS X 6	1	45	D314F-DC-00	NIPPLE CLOSE 1/2 IPS	2	15	D2594	SOLENOID VALVE 1/2 IPS	1
76	D1012	PRESSURE REG & STRAINER 3/4 IPS	1	46	D2102A	STEAM TRAP 1/2 IPS	2	16	D318F-D3-D2	UNION 1/2 C X 1/2 MIPS	1
77	D2340	BALL VALVE 3/4 IPS	1	47	D207A-B4-25	COPPER TUBING 1/2 CTS X 6 1/4	1	17	D207A-B4-38	COPPER TUBING 1/2 CTS X 9 1/2	1
78	D317A-F3-F2	ADAPTER 1" C X 1" MIPS	1	48	D320A-E303E1	TEE 3/4 C X 1/2 C X 3/4 FIPS	1	18	D323A-G4-D3	RED BUSH 1 1/4 FTG X 1/2 C	1
79	D207A-B8-16	COPPER TUBING 1" IPS X 4	1	49	D207A-B6-31	COPPER TUBING 3/4 CTS X 7 3/4	1	19	D320A-G3C3J3	TEE 1 1/4 C X 1 1/4 C X 2 C	1
80	D316A-F3-F2	90° ELBOW 1" C X 1" MIPS	1	50	D320A-E303E3	TEE 3/4 C X 1/2 C X 3/4 C	1	20	D317A-J3-J2	ADAPTER 2" C X 2" MIPS	1
81	-	SAME AS ITEM #28	1	51	D207A-B6-19	COPPER TUBING 3/4 CTS X 4 3/4	1	21	D207A-B16-23	COPPER TUBING 2" CTS X 5 3/4	1
82	D318A-F3-F2	UNION 1" C X 1" MIPS	1	52	D318A-D3-D2	UNION 1/2 C X 1/2 MIPS	1	22	D2756	"Y" STRAINER 2" IPS	1
83	D207A-B8-31	COPPER TUBING 1" CTS X 7 3/4	1	53	D322F-F2-D1	HEX RED BUSH 1" MIPS X 1/2 FIPS	1	23	D314F-JC-00	NIPPLE CLOSE 2" IPS	1
84	D316A-F4-F3	90° ELBOW 1" FTG X 1" C	1	54	D317A-E3-D2	ADAPTER 3/4 C X 1/2 MIPS	1	24	D2757	BALL VALVE 2" IPS	1
85	D323A-G4-F3	FLUSH BUSH 1 1/4 FTG X 1" C	1	55	D207A-B4-157	COPPER TUBING 1/2 CTS X 39 1/4	1	25	D207A-B10-10	COPPER TUBING 1 1/4 CTS X 2 1/2	1
				56	-	-	-	26	D320A-G3E3F3	TEE 1 1/4 C X 3/4 C X 1 C	1
				57	D318A-D303	UNION 1/2 C X 1/2 C	1	27	D317A-F4-F2	ADAPTER 1" FTG X 1" MIPS	1
				58	D207A-B4-101	COPPER TUBING 1/2 CTS X 25 1/4	1	28	D2772	SOLENOID VALVE 1" IPS	1
				59	D316A-D3-D3	90° ELBOW 1/2 C	3	29	D314F-FS-21	NIPPLE 1" IPS X 2 5/8	1
				60	D207A-B4-9	COPPER TUBING 1/2 CTS X 2 1/4	1	30	D319F-F1-F1	90° UNION ELL 1" IPS	1

FOR 70" RISE

FOR 40" RISE

NOTE:
1. (ITEM #7) ADD SUFFIX "NM" FOR NON-MAGNETIC MACHINES.
2. (ITEM #69) USE PART NO. D2396 AS STANDARD AND PART NO. D2301 WHEN LOW TEMP. CUT-OFF IS SPECIFIED.

SHEET 3 OF 3

TOLERANCES	FRACTIONS ±1/64	DECIMALS	.XXX ± .005	.XX ± .01	ANGLES ±1/2°	UNLESS OTHERWISE SPECIFIED
REV	ECN NO	DATE	A	979	1.17.94	
FILE:	PARTS\1390-74					
TITLE	STEAM PIPING		WASH & RINSE TANKS		AS NOTED	
MAT'L	STEAM PIPING		WASH & RINSE TANKS		SCALE 1"=8" CENTURY	
NEXT ASSY DWG. NO.	1390-1		REC'D 1		USED ON 1390-74	
Machine Company			Philadelphia, PA 19135			DRWN/DATE
Insinger			(215) 624-4800			PG
Machine Company			FAX (215) 624-6966			4.26.93

ITEM	PART NO.	SIZE	DESCRIPTION	QTY.
16	D317A-JA1	-	ADAPTER 2 CTS X 2 PPS	1
17	D207A-B12-10	-	COPPER TUBING 1 1/2 CTS X 2 3/8 LG	1
18	D-135	A	DRAIN FLANGE	1
19	D-514	A	GASKET	2
20	D-106	A	DRAIN STRAINER	2
21	D-90	A	GLASS DRAIN STRAINER	2
22	D-134	A	DRAIN FLANGE	1
23	D207A-B12-16	-	COPPER TUBING 1 1/2 CTS 4 LG	1
24	D207A-B14-20	-	COPPER TUBING 2 CTS X 4 7/8 LG	1
25	D346A-H3-H3	-	Y 45° 1 1/2 C	2
26	D346A-H3-H3	-	ELL 45° 1 1/2 C	1
27	D207A-B12-68	-	COPPER TUBING 1 1/2 CTS X 14 3/4 LG	2
28	I33-64	A	DRAIN HANDLE BRACKET	2
29	I390-68	A	DRAIN HANDLE BRACKET	1

ITEM	PART NO.	SIZE	DESCRIPTION	QTY.
1	D305A-H3-H3	-	UNION	1
2	B51-1	A	DRAIN ASSEMBLY	3
3	D207A-B12-7	-	COPPER TUBING 1 1/2 CTS X 1 5/8 LG	2
4	D347A-H3-H3	-	90° ELL 1 1/2 C	4
5	D207A-B12-65	-	COPPER TUBING 1 1/2 CTS X 16 1/4 LG	1
6	D346A-H3-H3	-	TEE 1 1/2 C	1
7	D207A-B12-57	-	COPPER TUBING 1 1/2 CTS X 9 1/4 LG	1
8	D207A-B12-23	-	COPPER TUBING 1 1/2 CTS X 5 3/4 LG	1
9	D207A-B12-65	-	COPPER TUBING 1 1/2 CTS X 16 1/4 LG	1
10	D207A-B12-61	-	COPPER TUBING 1 1/2 CTS X 15 1/4 LG	1
11	D207A-B12-63	-	COPPER TUBING 1 1/2 CTS X 20 3/4 LG	1
12	D207A-B12-115	-	COPPER TUBING 1 1/2 CTS X 28 3/4 LG	1
13	D346A-IJ3J3J	-	TEE 1 1/2 C X 2 C X 2 C	1
14	D347A-Q-JJ	-	90° ELL 2 C	1
15	D207A-B16-33	-	COPPER TUBING 2 CTS X 8 1/4 LG	1

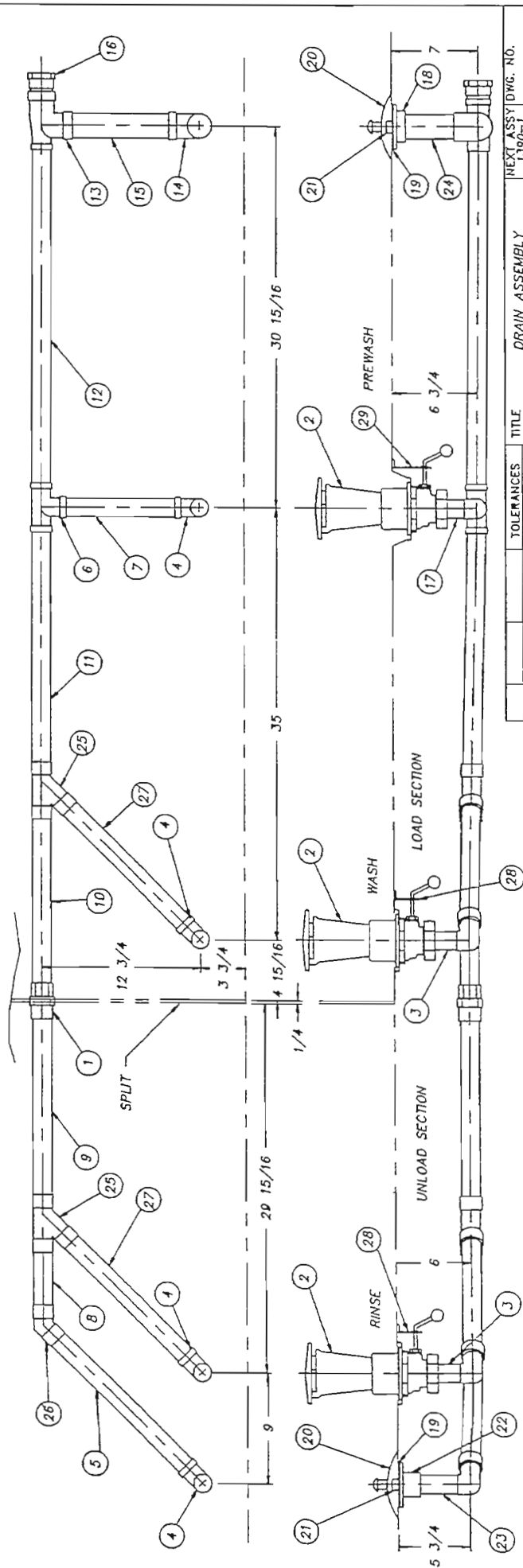

TOLERANCES		TITLE		NEXT ASSY DWG. NO.	
FRACTIONS ±1/64	DECIMALS	DRAIN ASSEMBLY	1390-1	1390-1	1390-73
.XXX ± .005	.XX ± .01	PREWASH, WASH, RINSE	SCALE	1/8	USED ON
ANGLES ±1/2°	OTHERS	NOTED	SCALE	1/8	CENTURY
OTHERS	FILE: PARTS\1390-73	Machine Company	INSINGER	Philadelphia, PA 19135	DATE
				(215) 674-4800	PC
				FAX (215) 624-8866	4.21.93

SHEET 1 OF 2
R.H. MACHINE SHOWN

ITEM	PART NO.	SIZE	DESCRIPTION	QTY.
16	D317A-14-11	-	ADAPTER 2 CTS X 2 FPS	1
17	D207A-B12-10	-	COPPER TUBING 1 1/2 CTS X 2 3/8 LG	1
18	D-133	-	DRAIN FLANGE	1
19	D-514	A	CASKET	2
20	D-100	A	DRAIN STRAINER	2
21	D-90	A	CLASP DRAIN STRAINER	2
22	D-134	-	DRAIN FLANGE	1
23	D207A-B12-16	-	COPPER TUBING 1 1/2 CTS X 4 LG	1
24	D207A-B16-20	-	COPPER TUBING 2 CTS X 4 7/8 LG	1
25	D207A-B12-10	-	COPPER TUBING 1 1/2 CTS X 2 3/8 LG	1
26	D332A-H3-0H3	-	"Y" 45° 1 1/2 C	2
27	D207A-B12-59	-	COPPER TUBING 1 1/2 CTS X 14 3/4 LG	2
28	1133-04	A	DRAIN HANDLE BRACKET	2
29	1390-88	A	DRAIN HANDLE BRACKET	1

ITEM	PART NO.	SIZE	DESCRIPTION	QTY.
1	D305A-H3-10	-	UNION	1
2	954-1	A	DRAIN ASSEMBLY	3
3	D207A-B12-7	-	COPPER TUBING 1 1/2 CTS X 1 5/8 LG	1
4	D347A-H3-H3	-	90° ELL 1 1/2 C	3
5	D207A-B12-34	-	COPPER TUBING 1 1/2 CTS X 8 1/2 LG	1
6	D348A-H3-H3	-	TEE 1 1/2 C	1
7	D207A-B12-37	-	COPPER TUBING 1 1/2 CTS X 9 1/4 LG	1
8	D207A-B12-100	-	COPPER TUBING 1 1/2 CTS X 30 3/4 LG	1
9	D207A-B12-161	-	COPPER TUBING 1 1/2 CTS X 40 1/4 LG	1
10	D207A-B12-13	-	COPPER TUBING 1 1/2 CTS X 3 1/4 LG	1
11	D207A-B12-29	-	COPPER TUBING 1 1/2 CTS X 7 1/4 LG	1
12	D207A-B12-07	-	COPPER TUBING 1 1/2 CTS X 16 3/4 LG	1
13	D344A-H3-00	-	TEE 1 1/2 C X 3 C X 2 C	1
14	D347A-03-03	-	90° ELL 2 C	1
15	D207A-B12-33	-	COPPER TUBING 2 CTS X 8 1/4 LG	1

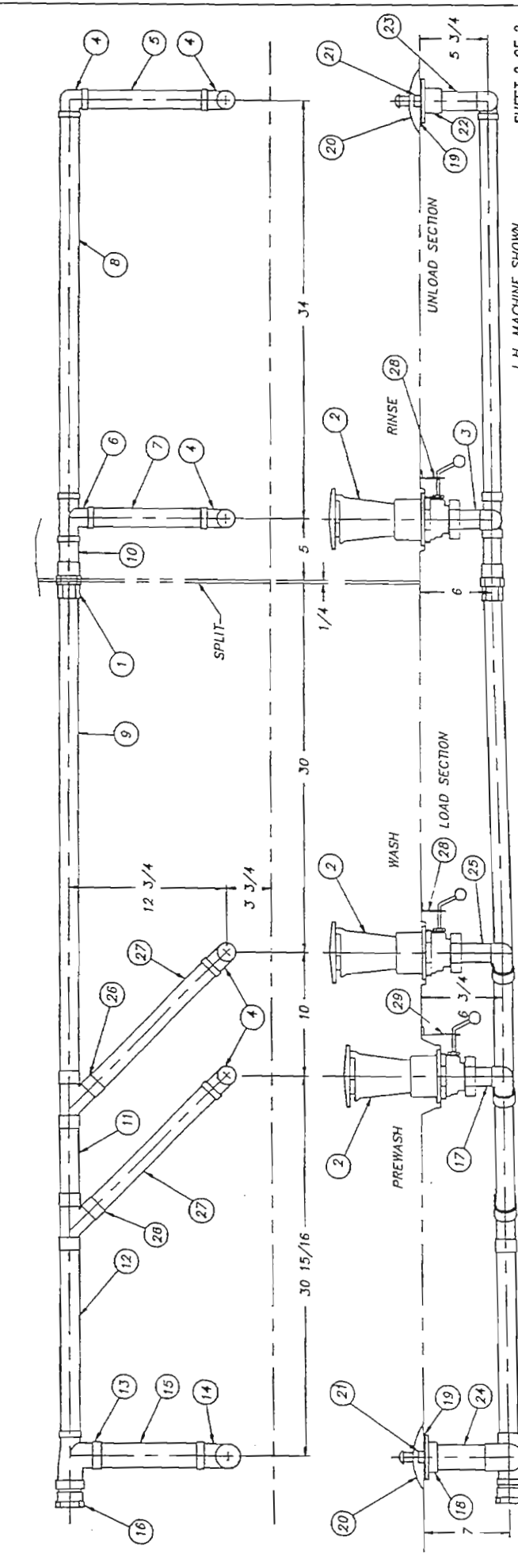

TOLERANCES		TITLE		SCALE		NEXT ASSY DWG. NO.	
FRACCTIONS	±1/64	DRAIN ASSEMBLY	RECD	1	1390-73	USED ON	1390-73
DECIMALS	.005	PREWASH, WASH, RINSE	SCALE	1/8	CENTURY	PC	4.21.93
XXX	±.005	NOTED	FILE: PARTS	1390-73	DATE	03/07/94	
XX	±.01	INSINGER	REV	ECN NO	DATE	03/07/94	
XX	±.01	Machine Company	REV	ECN NO	DATE	03/07/94	
ANGLES	±1/2°	Philadelphia, PA 19135	REV	ECN NO	DATE	03/07/94	
UNLESS OTHERWISE SPECIFIED		(215) 624-4800	REV	ECN NO	DATE	03/07/94	
		FAX (215) 624-8866	REV	ECN NO	DATE	03/07/94	

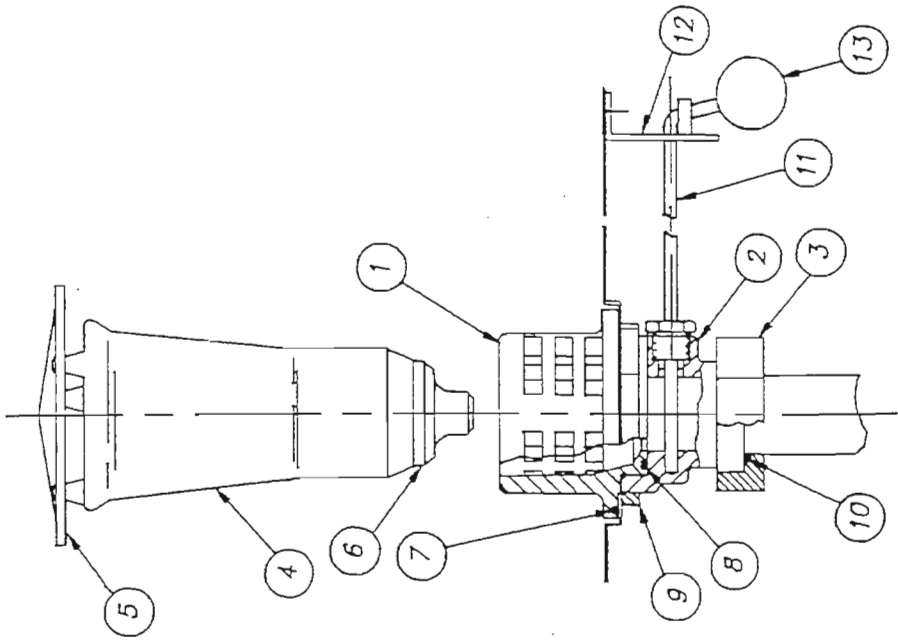

ITEM	PART NO.	DESCRIPTION	QTY.
	954-50	DRAIN ASS'Y (COMPLETE)	-
1	954-50A	UPPER BODY	1
2	954-50B	LOWER BODY	1
3	954-50C	NUT	1
4	954-50D	OVERFLOW TUBE	1
5	D-193	SKIMMER CAP	1
6	D2-557	"U"-CUP SEAL -- DRAIN SEAT	1
7	D2-548	"O" RING	1
8	D2-549	"O" RING	1
9	D-305	DRAIN JAM NUT	1
10	D2-550	"O" RING	1
11	1100-79	DRAIN HANDLE ASSEMBLY	1
12	1100-156	BRACKET -- W & R	1
	1100-157	BRACKET -- PIW	1
13	D-2407	BALL	1

TOLERANCES		TITLE	NEXT ASSY DWG. NO.
FRACTIONS	±1/64		
DECIMALS	.XXX ±.005	MATL	REQD
ANGLES	±.01	NOTED	SCALE 1/4
UNLESS OTHER SPECIF.			USED ON RACKLESS "W"
REV	ECN NO	DATE	DRWN/DATE
			EE
FILE: SKETCHA \SK-2613		Philadelphia, PA 19135 (215) 624-4800 FAX (215) 624-6966	
		Insinger Machine Company 2.01.83	

ITEM	PART NO.	DESCRIPTION	QTY.
1	UP-1	PUMP BODY	1
2	D-435	ADAPTER	1
3	NOTED	IMPELLER	1
4	SUP-3	END COVER PLATE	1
5	D3-805	PUMP SHAFT	1
6	D3-816	MOUNTING BRACKET	1
7			
8	UP-8	END COVER GASKET	1
9	UP-9	HOUSING COVER GASKET	1
10	UP-13	FLINGER	1
11	UP-15	CERAMIC SEAL	1
12	D309C-JC-6A	END COVER BOLT	12
13			
14	D302-1	KEY	1
15	D3-824A	WASHER	1
16	D313C-J2	LOCKWASHER	1
17	D309C-JC-5A	IMPELLER BOLT	1
18	D313A-J1	WASHER	12
19			
20	D309C-GC-2H	SET SCREW	2

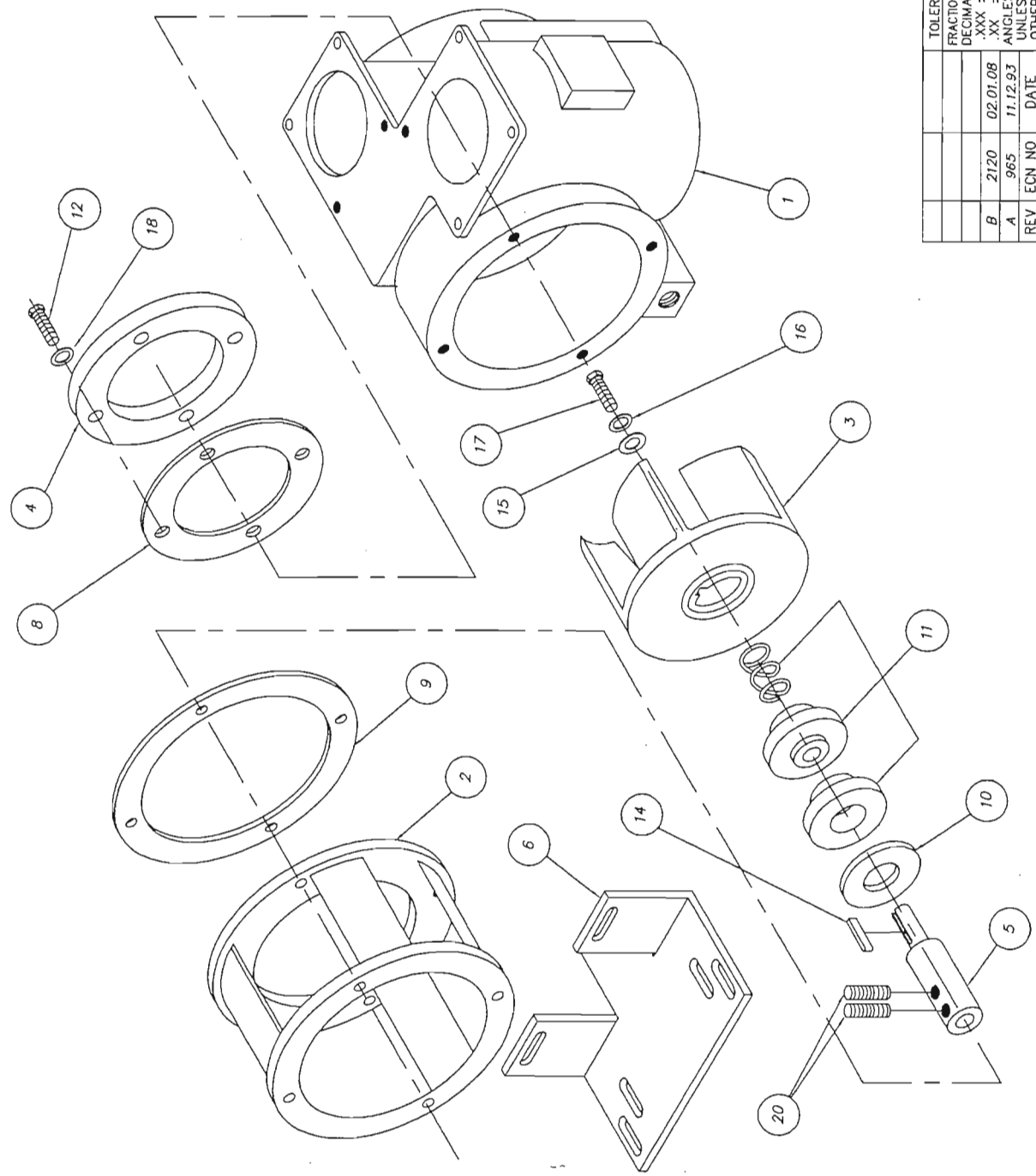

NOTE:
 FOR COMPLETE ASSEMBLY USE PART NO. D2471A
 IMPELLER PART NO. & SIZE:
 SUP-2A 4 1/2" (MODULAR, SPEEDER)
 SUP-9A 5" (ADMIRAL WASH, SUPER W&R, CLIPPER/MASTER
 /CENTURY PW ONLY)

TOLERANCES		TITLE		NEXT ASSY DWG. NO.	
FRACTIONS	±1/64		PUMP ASSEMBLY	REQD	1
DECIMALS	.XXX ± .005	B	MODEL 2 1/2 SUP	SCALE	FULL
	.XX ± .04	A	MATL	USED ON	
	ANGLES ±1/2°	REV			
	UNLESS OTHERWISE SPECIFIED	ECN NO.			
		DATE			
		FILE: SKETCH\SK-2456A			



Philadelphia, PA 19135
 (215) 624-4800
 FAX (215) 624-6966

DRWN/DATE
 PG
 8.29.94

ITEM	PART NO.	SIZE	DESCRIPTION	QTY.	ITEM	PART NO.	SIZE	DESCRIPTION	QTY.
1	D317A-H2-H4	-	FTG. ADAPTER 1 1/2 MIPS X 1 1/2 FTG	1	7	D309C-JC-10	-	HEX HD SCR 3/8-16 X 1 1/4 LG	4
2	D316A-H3	-	ELBOW 90° 1/2 C	1	8	D313A-1J	-	COPPER WASHER 3/8	4
3	D207A-B12-6	-	COPPER TUBING 1 1/2 CTS X 1 1/2 LG	1	9	D312C-JC-5	-	LOCKNUT 3/8-16	4
4	D-514	A	GASKET	1	10	D2-541	A	STRAINER	1
5	D-134	A	FLANGE, TANK	1	11	D3-825	A	CLASP	1
6	963-38	A	FLANGE, STRAINER	1	12	D312C-EC-6	-	ACORN NUT #10-32 S/S	1

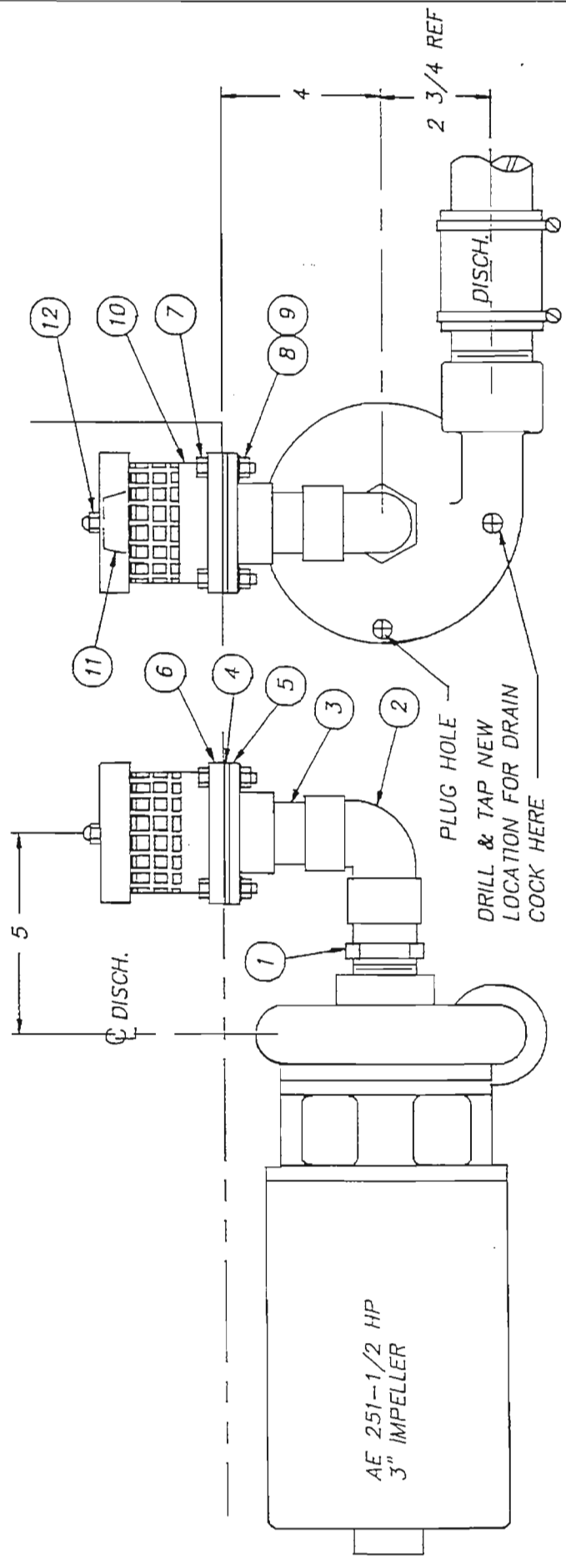

USED ON :
 SPEEDER 86-3
 ADMIRAL 66-3

TOLERANCES	TITLE	NEXT ASSY DWG. NO.
FRACTIONS ±1/64	SUCTION LINE	1182-13
DECIMALS	ASSY - PREWASH	REQ'D NOTED
.XXX ± .005	MATL	SCALE 1=4
.XX ± .01	NOTED	USED ON NOTED
ANGLES ±1/2°		
UNLESS OTHERWISE SPECIFIED		
D 898 7.16.93		
REV ECN NO DATE		
FILE: PARTS\1182-13		

Insinger
 Machine Company
 Philadelphia, PA 19135
 (215) 624-4800
 FAX (215) 624-6966
 DRWN/DATE
 PG
 7.15.93

ITEM	PART NO.	DESCRIPTION	QTY.
1	D2-541	STRAINER	1
2	D2-1350	STRAINER FLANGE	1
3	D-530	GASKET	1
4	D313A-1J	WASHER COPPER 3/8	2
5	D309C-CJ-10A	HEX HD SCR 3/8-16 X 1 1/4	2
6	D309C-CJ-11A	HEX HD SCR 3/8-16 X 1 3/8	2
7	D312C-JC-5	HEX LOCKNUT 3/8-16	2

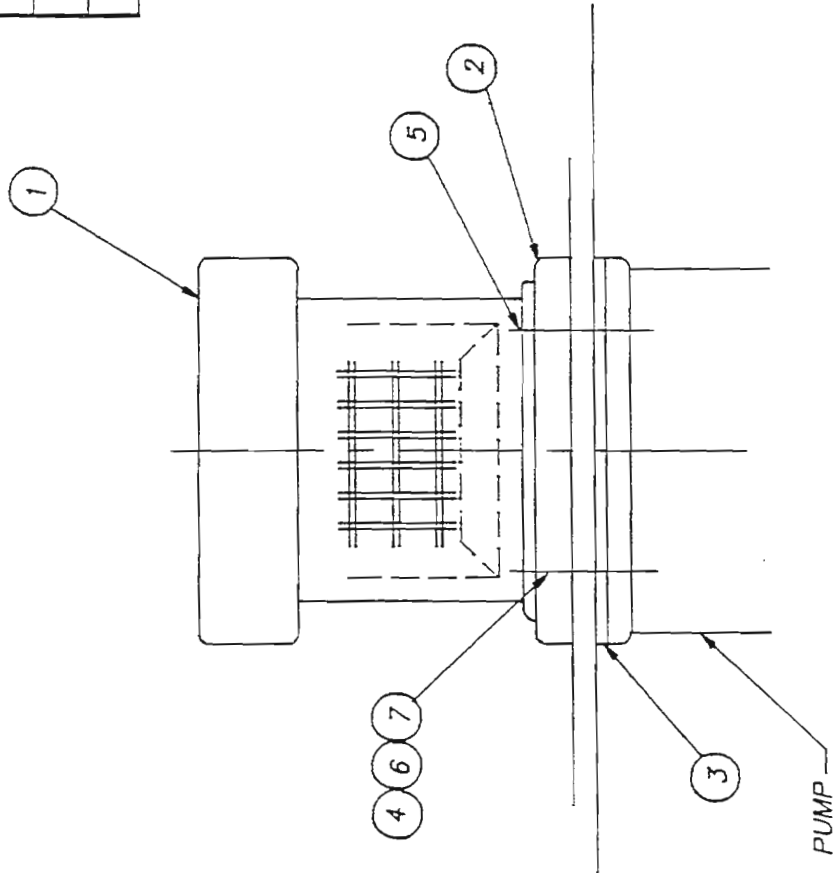

USED ON CLIPPER RC 21 W

TOLERANCES	TITLE	NEXT ASSY	DWG. NO.
FRACTIONS ±1/64	PUMP SUCTION	REQ'D	1100-76
DECIMALS	ASSEMBLY	SCALE	USED ON
.XXX ± .005	MAT'L	1=2	SEE ABOVE
.XX ± .01	NOTED		
ANGLES ±1/2°			
UNLESS OTHERWISE SPECIFIED			
REV	ECN NO	DATE	
FILE: PARTS\1100-76			



Insigner
Machine Company

Philadelphia, PA 19135
(215) 624-4800
FAX (215) 624-6966

DRWN/DATE
PG
1.4.92

In order to insure the proper operation of your INSINGER dishwasher, it is necessary that the LIQUID LEVEL FLOAT be wiped free of any residue and/or moisture at each cleaning. This should be done, preferably, after each use of the machine, or, at a minimum, once each day.

The LIQUID LEVEL FLOAT is located below the scrap screens in those tanks which contain water heating devices (coils, steam injectors, or electric immersion heaters) and pump inlet strainers. They are usually located, in rackless and rack conveyor style machines, on the inside tank wall, at approximately water level, opposite and parallel to the inspection doors. In the door, stationary rack, type machines, the LIQUID LEVEL FLOAT may be found beneath the scrap screen.

Below is a depiction of the LIQUID LEVEL FLOAT and the surfaces which must be wiped clean.

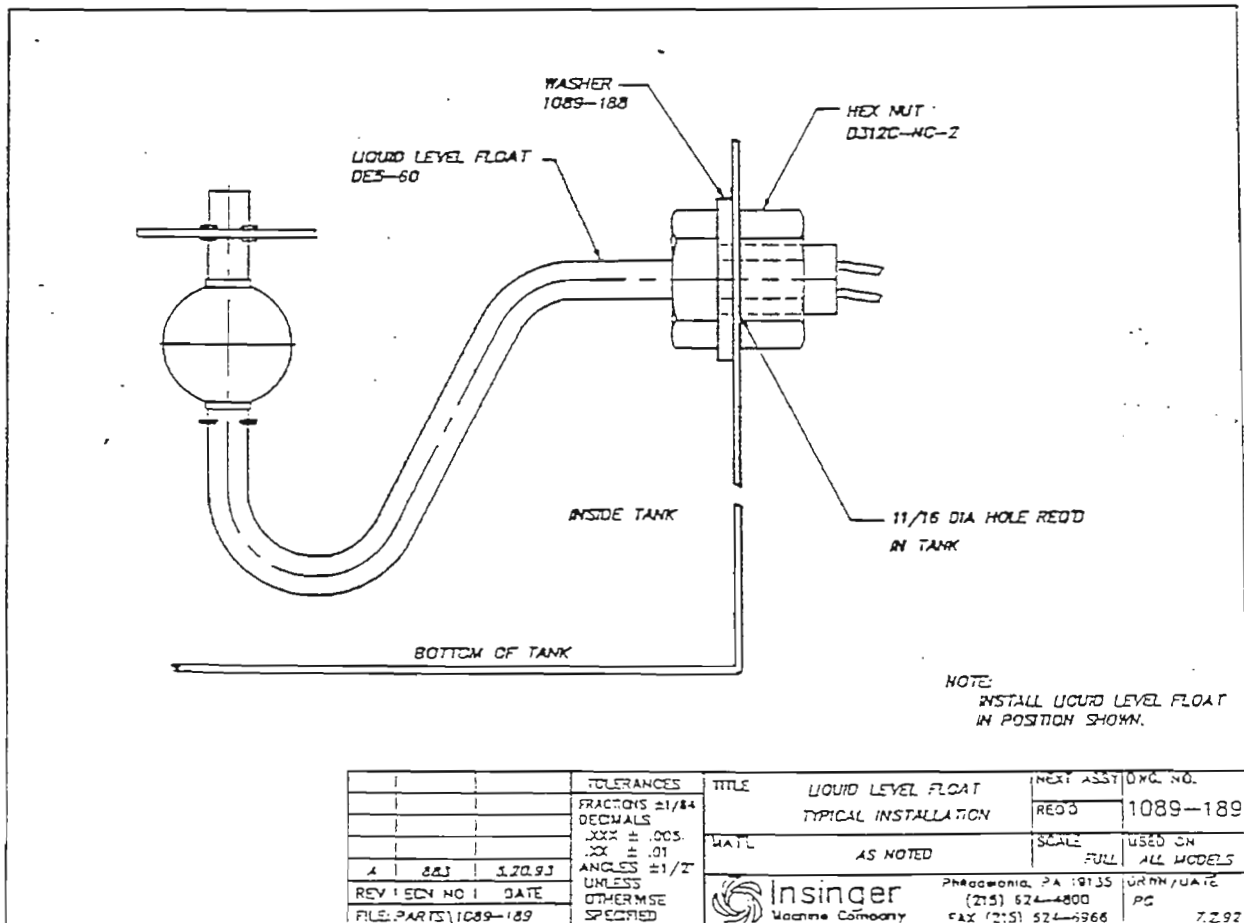

ITEM	PART NO.	SIZE	DESCRIPTION	QTY.
1	D2-867	A	SWITCH BRACKET	2
2	DEB-47	-	SWITCH, START/STOP	2
3	D309C-CC-5G	-	WELDSTUD 1/4-20 X 5/8 LG	4
4	D312C-CC-5	-	LOCKNUT 1/4-20	4

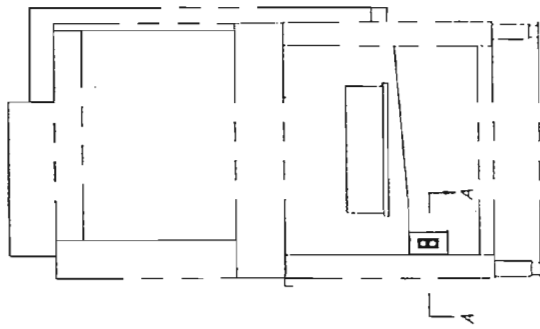

LOAD END

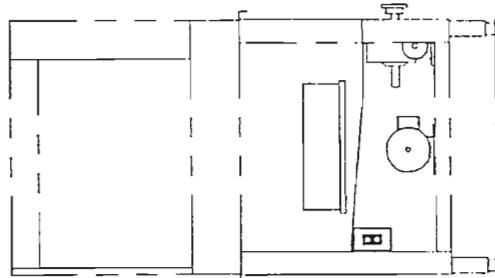

UNLOAD END

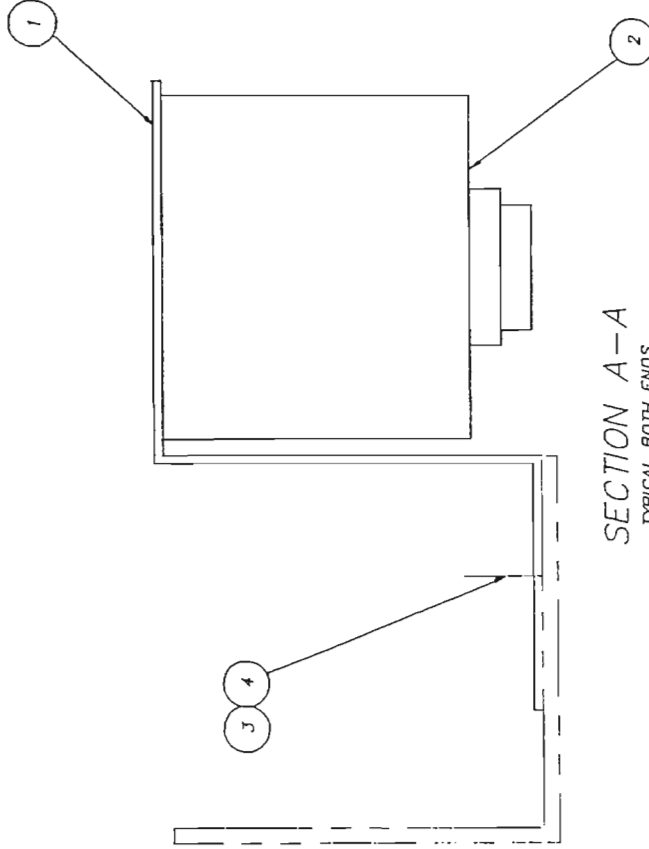

SECTION A-A
TYPICAL BOTH ENDS

TOLERANCES	TITLE	START/STOP	NEXT ASSY DWG. NO.
FRACTIONS ±1/64	REGD 1	STATION	1390-95
DECIMALS .XXX ±.005	MATL	NOTED	SCALE 1=16
.XX ±.01			USED ON CENTURY
ANGLES ±1/2°			DRWN/DATE
UNLESS OTHERWISE SPECIFIED			PG
REV ECN NO DATE	Philadelphia, PA 19135 (215) 624-4800 FAX (215) 624-8868		
FILE:PARTS\1390-03	9.3.93		

NO	NAME	DWG. NO.	REQ.
1	RACK SECTION ROD	DWG. 1100-138	2
2	UPPER ROD	DWG. D3-810	1
3	CENTER PEG W/MTG. HOLES	DWG. D2-536	1
4	END PEG	DWG. D2-536 C	1
5	END PEG (NOT SHOWN)	DWG. D2-536 D	1
6	DRIVE SCREW RD. HD. TYPE U	#8 - 32 X 3/8 LG	2
7	ROD PIN	DWG. D2-852	2
8	RACK SECTION PLATE	DWG. D2-736	2
9	CENTER PEG W/O HOLES	DWG. D2-536 N	6

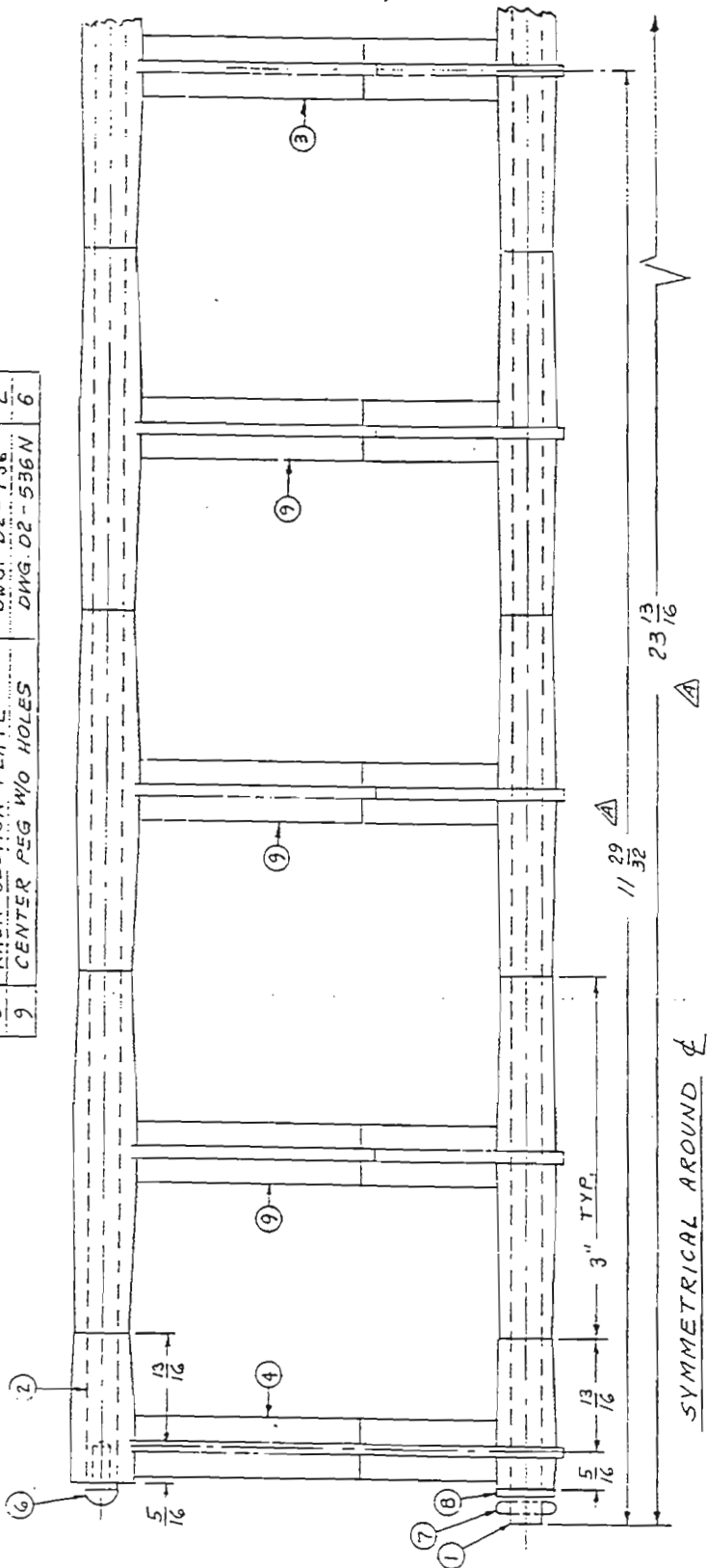

SYMMETRICAL AROUND ϕ

(SAME AS D-2463)

MACHINE	RC MACHINE	W	DWG. NO. 1100-137
TITLE	POLY RACK SECTION - FIRE RETARDANT	SCALE	PATT. NO.
MAT'L	REQ.	SCALE	1/1
INSINGER MACHINE CO.		CHKD.	DRWN 9-15-83
PHILA., PA. 19135		APPD.	

QTY. (1) WAS (7) (ITEM # 3) AND
 ADDED ITEM # 9 OF 110.05
 29/3/16 WAS 24 1/16. 11/22/82 WAS 12/38. 8/1.2.04

NO.	DESCRIPTION	PART NO.	REQ.
1	ROD - RACK SECTION	DWG. 1100-138	2
2	PEG-CENTER	DWG. D2-536G	1
3	PEG-END	DWG. D2-536J	1
4	PEG-END (NOT SHOWN)	DWG. D2-536K	1
5	PIN - ROD	DWG. D2-852	2
6	PLATE - RACK SECTION	DWG. D2-736	2
7	PEG - INTERMEDIATE	DWG. D2-536H	6

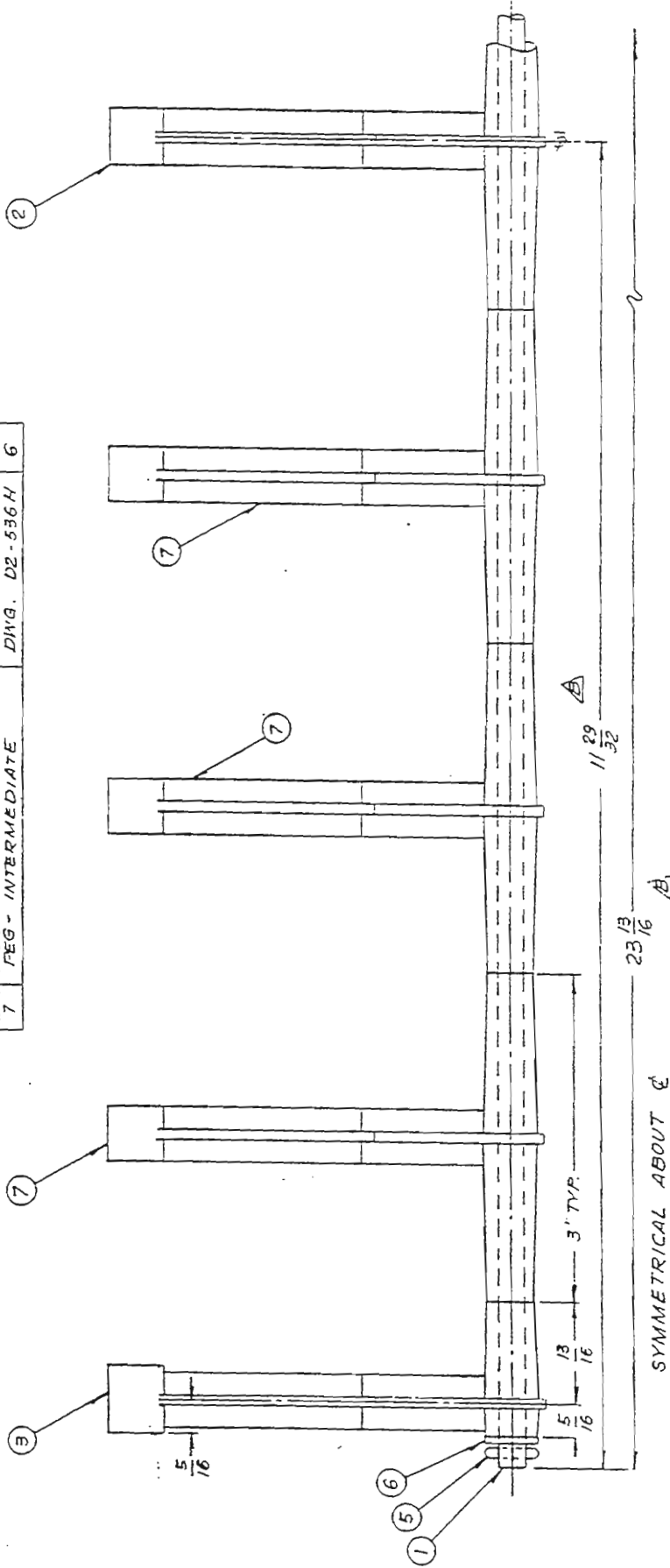

(SAME AS D-2510)

TOLERANCES	TITLE	PART NO.	DWG. NO.
FRACTIONS ± 1/64	POLY RACK	REQ. —	1100-139
DECIMAL ± .005	SECTION ASS'Y.	SCALE 1/2	USED ON COPPER W/ MASTER
ANGULAR ± 1/2°	MATL. NOTED		APR 9, 1953
UNLESS OTHERWISE SPECIFIED	INSINGER MACHINE CO.		
	PHILA., PA. 19135 (215) 624-4800		

23 13/16 WAS 24 1/16, 11 29/32 WAS 12 1/32, RP 1.2.84

D2-536J WAS D2-536C (ITEM # 3) AND D2-536K WAS D2-536D (ITEM # 4) RP 1.9.84

NO.	NAME	DWG. NO.	REQ.
1	PEG - END	D-593 LONG BOSS SHORT BOSS	2
2	PEG	D-594 LONG	4
3	PEG (RC-15-222)	D-2167 LONG	2
4	SPACER 1 1/2 LG	D-595	3
5	SPACER 1 3/2 LG	D-592 SHORT	18
6	SPACER 1 2 1/2 LG	D-592 LONG	4
7	UPPER ROD	D2-895	3
8	RACK SECT. ROD	D2-954	2
9	RACK SECT. PLATE	D2-736	2
10	RACK SECT. ROD PIN	D2-852	2
11	DRIVE SCREW #8-32 x 3/8 LG	RD. HD. TYPE U	6

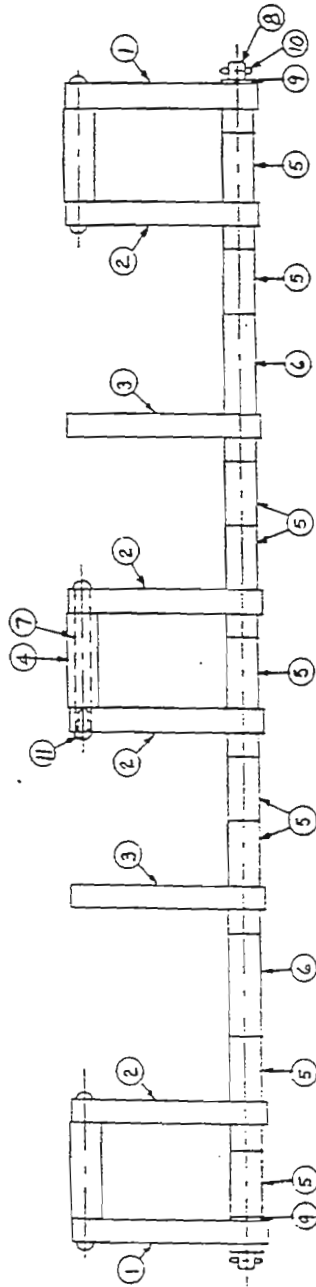
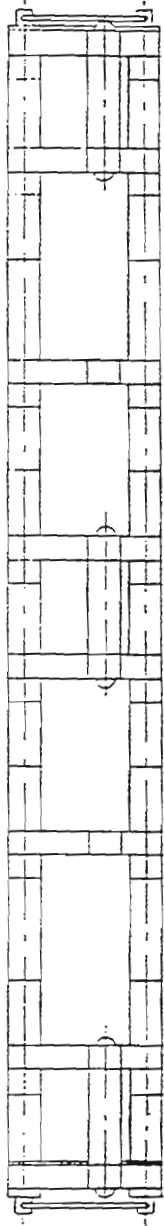

MACHINE	CLIPPER RC-21	DWG. NO.	997-5
TITLE	POLY RACK SECTION ASSY.	PATT. NO.	
MAT'L		REQ.	1/2
		SCALE	1/2
INSINGER MACHINE CO.		CHKD.	
PHILA., PA. 19135		APPD.	
		DRWN.	B.F. 5.22.79

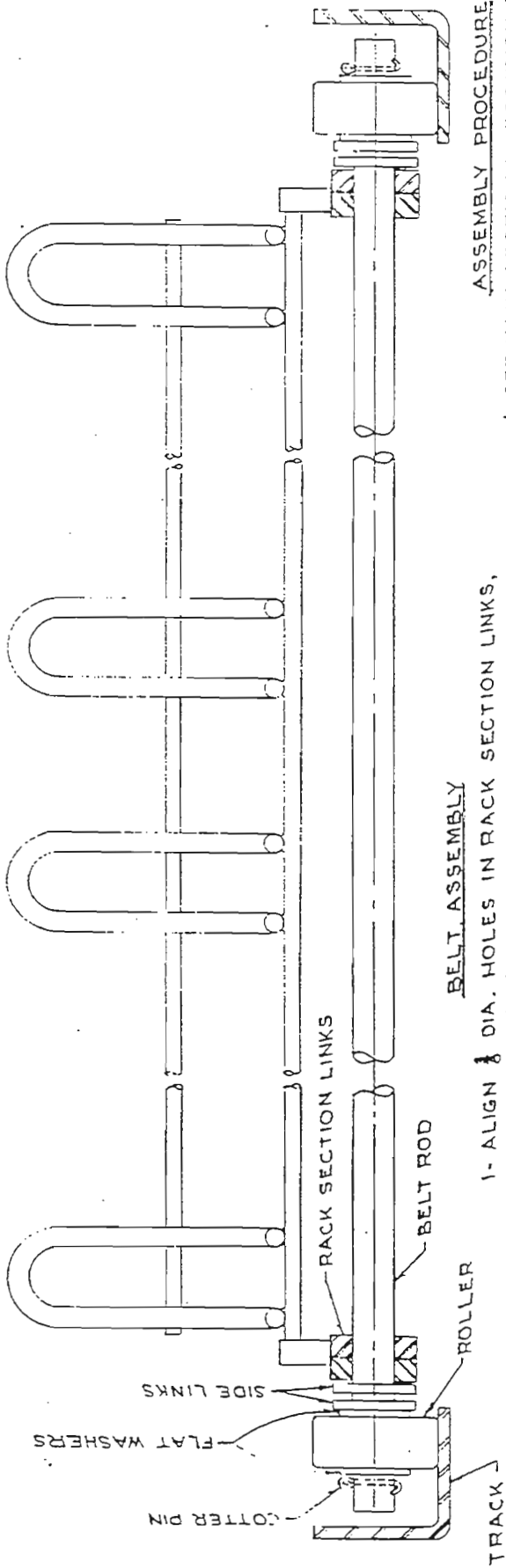

- BELT ASSEMBLY
- 1- ALIGN 1/4 DIA. HOLES IN RACK SECTION LINKS, AND SIDE LINKS.
 - 2- LIFT BELT SO HOLES ARE ABOVE TRACK.
 - 3- INSERT BELT ROD THRU SIDE LINKS & RACK SECTION LINKS.
 - 4- INSTALL FLAT WASHERS & ROLLERS AS SHOWN.
 - 5- INSTALL COTTER PINS.

ASSEMBLY PROCEDURE

- 1- SET MAIN SECTION IN POSITION & CHECK LEVELNESS. LEVEL MACHINE BY TURNING ADJUSTABLE FEET UP & DOWN.
- 2- LOOSELY BOLT LOAD & UNLOAD SECTIONS TOGETHER AT BASE FRAME & DOOR OPENINGS. BE SURE TO APPLY GASKET SEALER LIBERALLY.
- 3- LEVEL LOAD & UNLOAD SECTIONS, ALIGN TRACKS & THEN FASTEN BOLTS SECURELY.
- 4- LOOSEN BELT TAKE UP BOLTS & JOIN CONVEYOR BELT IN 4 PLACES (SEE BELT ASSEMBLY) ADJUST TAKE UP BOLTS TO REMOVE EXCESS SLACK. DO NOT OVERTIGHTEN.
- 5- UNIONS OR DISCONNECTS HAVE BEEN PROVIDED WHERE SECTIONS JOIN. CONNECT ALL PIPING & CONDUIT.
- 6- CONNECT WIRES AS PER WIRING DIAGRAM.

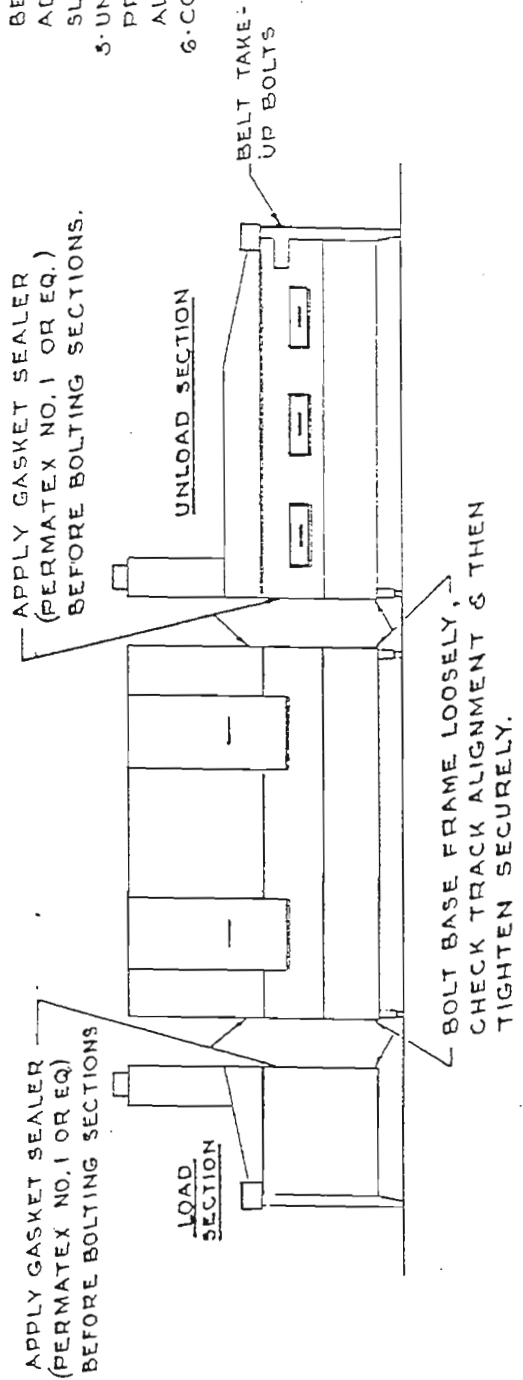

TYPICAL ASSEMBLY PROCEDURE
FOR RACKLESS MACHINES

INSINGER MACHINE CO.
PHILA., PA. 19135

SK-2650

7-24-84

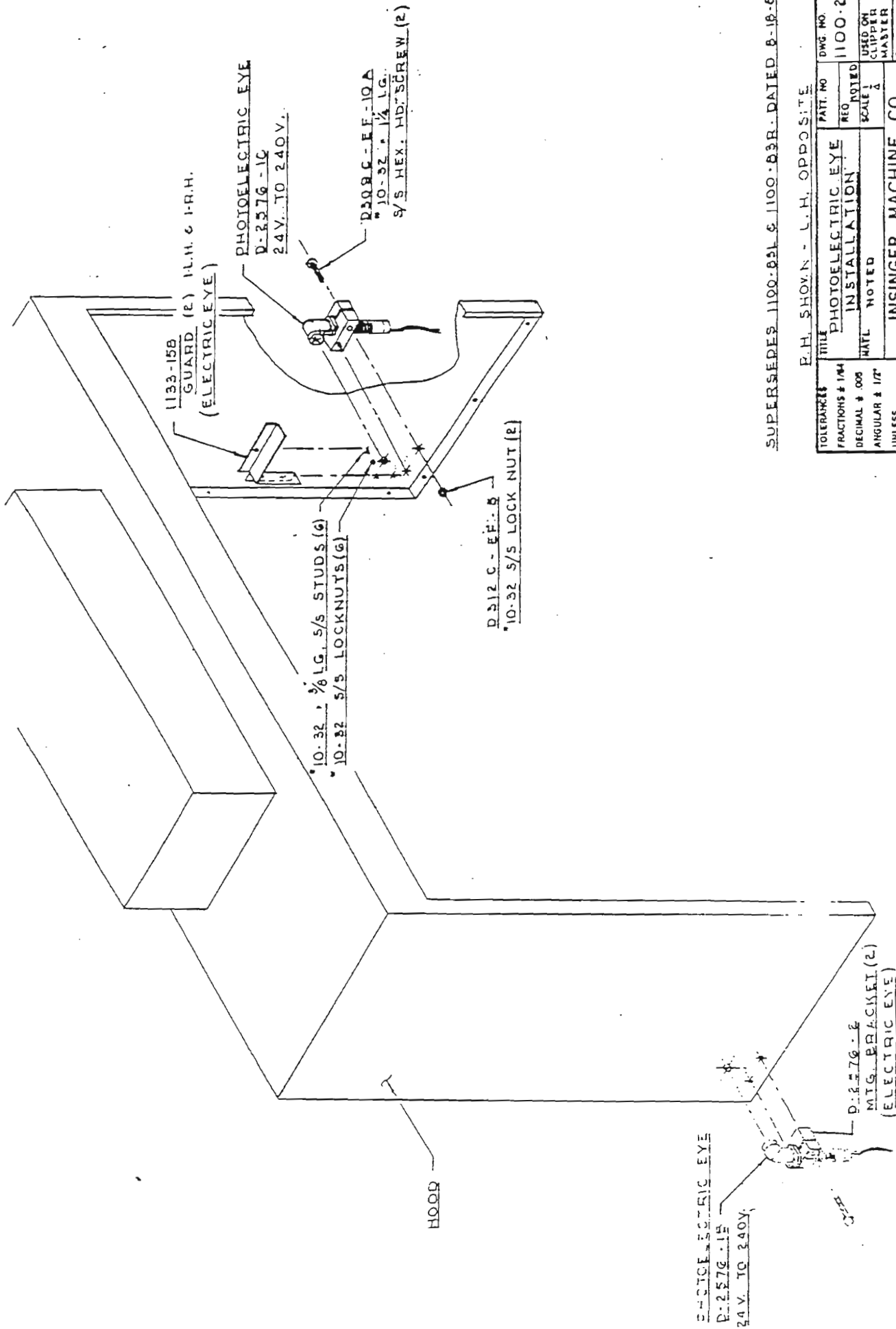

SUPERSEDES 1100-221 & 1100-238 DATED 8-18-63

E.H. SHOVN - L.H. OPPOSITE

TOLERANCES	TITLE	PART. NO.	DWG. NO.
FRACTIONS & 1/4	PHOTOELECTRIC EYE	REORDERED	1100-265
DECIMAL & .005	INSTALLATION	SCALE 1	USED ON
ANGULAR & 1/2	MATL. NOTED	MASTER W	CLIPPER W
UNLESS OTHERWISE SPECIFIED	INSINGER MACHINE CO.	PHILA., PA. 19135	(215) 624-4800
			5-4-CB

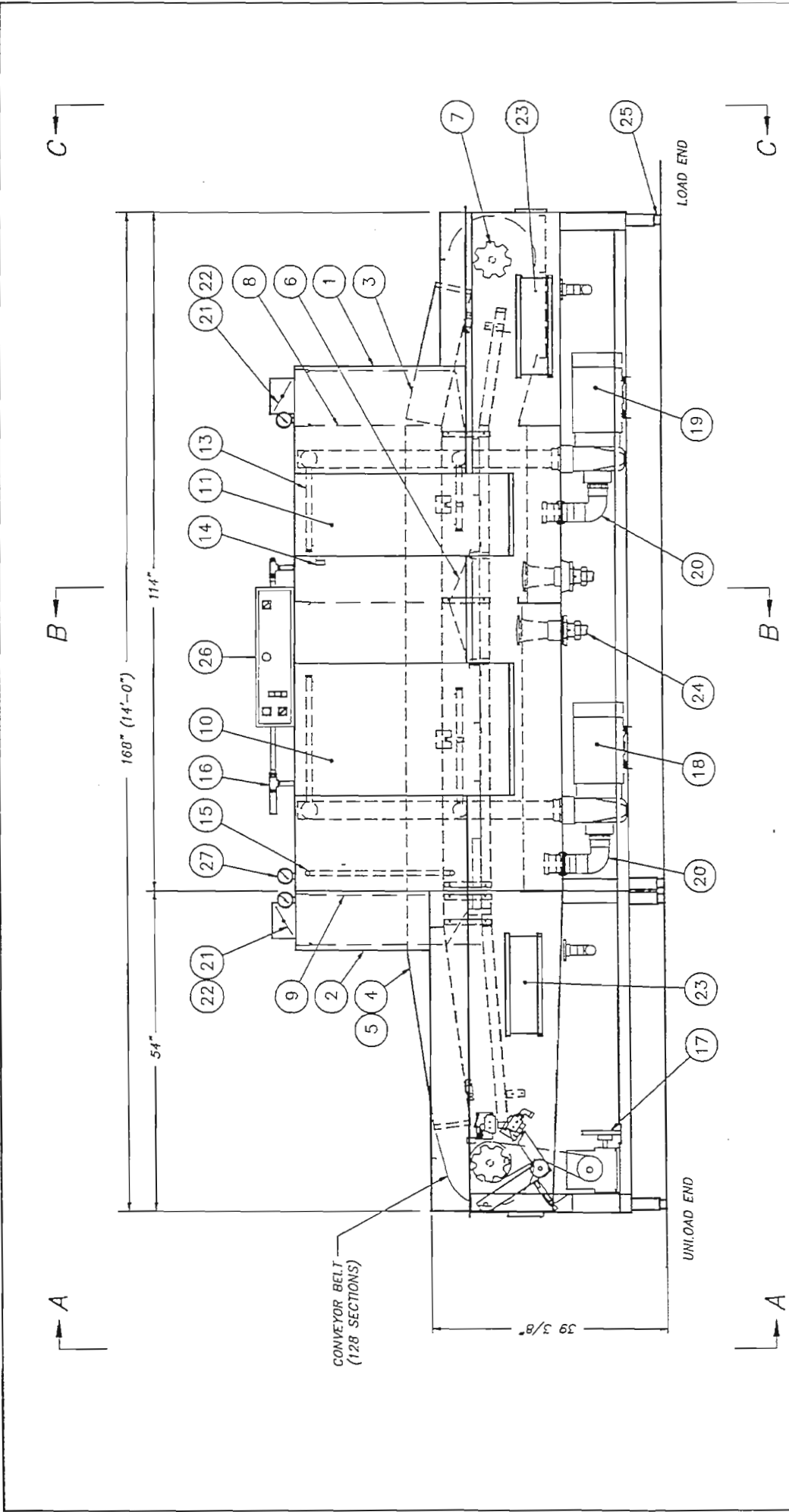

SHEET 1 OF 3

OPTION		DWG No	SIZE
1	ELECTRIC HEATER LOCATIONS	1462-58	B
2	STEAM PIPING-COILS	1462-86	B
J	STEAM PIPING-INJECTORS	1462-72	B
4	CLOSE-OFF PANELS	1462-95	B
5	CONVEYOR W/SILVERWARE TROUGH	1457-1	B

TOLERANCES	DEFENDER	TITLE	NEXT ASSY DWG. NO.
FRACTIONS ±1/64	R.H. MACHINE	MATL	1462-1
DECIMALS .XXX ±.005			
.XX ±.01			
ANGLES ±1/2°			
UNLESS OTHERWISE SPECIFIED			

REV	ECN NO	DATE	USED ON
			DEFENDER 14
			DRWN/DATE
			YC 2.25.87

Insinger
 Machine Company
 Philadelphia, PA 19135
 (215) 624-4800
 FAX (215) 924-8888

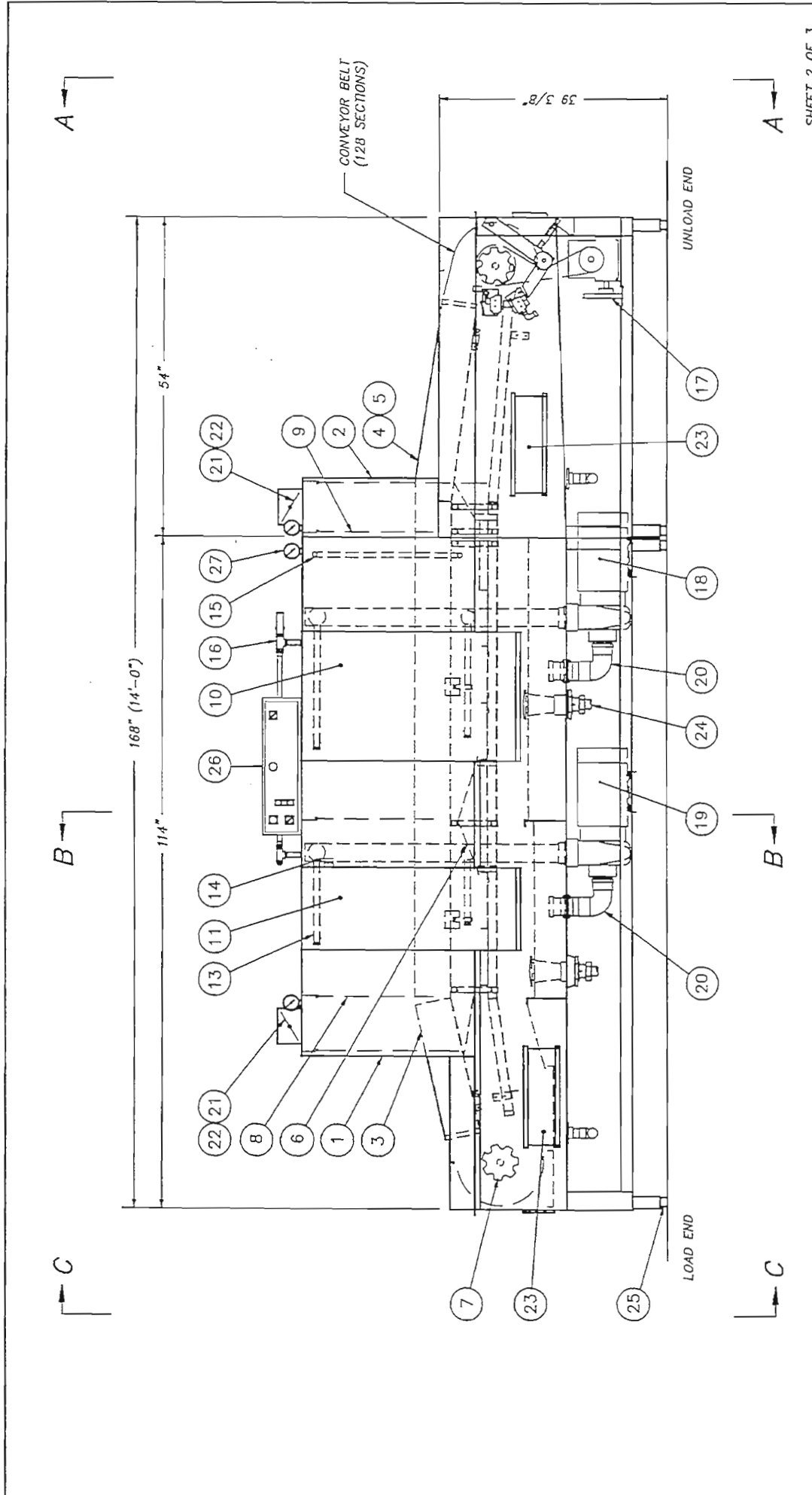

SHEET 2 OF 3

TITLE	DEFENDER	DEFENDER	REXT ASSY DWG. NO.	1462-1
MATL	L.H. MACHINE	RECD	SCALE	1-16 DEFENDER 14
REV	ECN NO	DATE	UNLESS OTHERWISE SPECIFIED	PHILADELPHIA, PA 19135
FILE: PARTS 1462-1				(215) 624-4000
				FAX (215) 624-6966

TOLEANCES	FRACTIONS ±1/64	DECIMALS	.XXX ± .005	.XX ± .01	ANGLES ±1/2°
REV	ECN NO	DATE			
FILE: PARTS 1462-1					

OPTION	DWG No	SIZE
1 ELECTRIC HEATER LOCATIONS	1462-58	B
2 STEAM PIPING-COILS	1462-86	B
3 STEAM PIPING-INJECTORS	1462-72	B
4 CLOSE-OFF PANELS	1462-95	B
5 CONVEYOR W/SILVERWARE TROUGH	1457-1	B

insinger
Machine Company

Philadelphia, PA 19135
(215) 624-4000
FAX (215) 624-6966

DRWN/DATE
YC 2.25.97

ITEM	PART NO.	SIZE	DESCRIPTION	QTY.
1	1462-2	B	SHELL ASSEMBLY, LOAD SECTION	1
2	1462-3	B	SHELL ASSEMBLY, UNLOAD SECTION	1
3	1462-4	B	TRACK INSTALLATION, LOAD SECTION	1
4	1462-5	B	TRACK INSTALLATION, UNLOAD SECTION (D-17)	1
5	1462-74	B	TRACK INSTALLATION, UNLOAD SECTION (D-14)	1
6	1462-7	B	BAFFLES & SCRAP SCREENS, LOAD SECTION	1
7	1462-21	B	DRIVEN SHAFT ASSEMBLY	1
8	1462-9	B	CURTAIN & BAFFLE INSTALL. LOAD SECTION	1
9	1462-10	B	CURTAIN & BAFFLE INSTALL. UNLOAD SECTION	1
10	1462-42	A	DOOR 23"	1
11	1390-32	A	DOOR 15"	1
12	1462-32	A	WEIR PLATE INSTALLATION	1
13	1462-82	B	DISCHARGE LINE ASSY. LOAD SECTION	1
14	D2715	A	DOOR LATCH	4
15	1462-59	B	FINAL RINSE ASSEMBLY	1
16	1462-60	B	AUTO TANK FILL ASSEMBLY	1
17	1390-72	B	CONVEYOR DRIVE ASSEMBLY	1
18	3091-K305	-	PUMP WASH	1
19	3043-K038	-	PUMP PREWASH	1
20	1462-69	A	PUMP SUCTION ASSEMBLY	2
21	D2-728	A	VENT DAMPER BLADE	2
22	D2-831	A	DAMPER ASSEMBLY	2
23	1100-94	A	TANK DOOR	4
24	1462-70	B	DRAIN ASSEMBLY	1
25	D2587	A	ADJUSTABLE FOOT ASSY	8
26	SEE SPEC.	B	CONTROL BOX	1
27	D2390	A	THERMOMETER	3
28	1438-6	B	ELECTRICAL CHANNEL -- STEAM	1
29	1438-7	B	ELECTRICAL CHANNEL -- ELECTRIC	1
29	1462-95	B	CLOSE-OFF PANELS	1
30	1390-95	B	START/STOP STATION	1

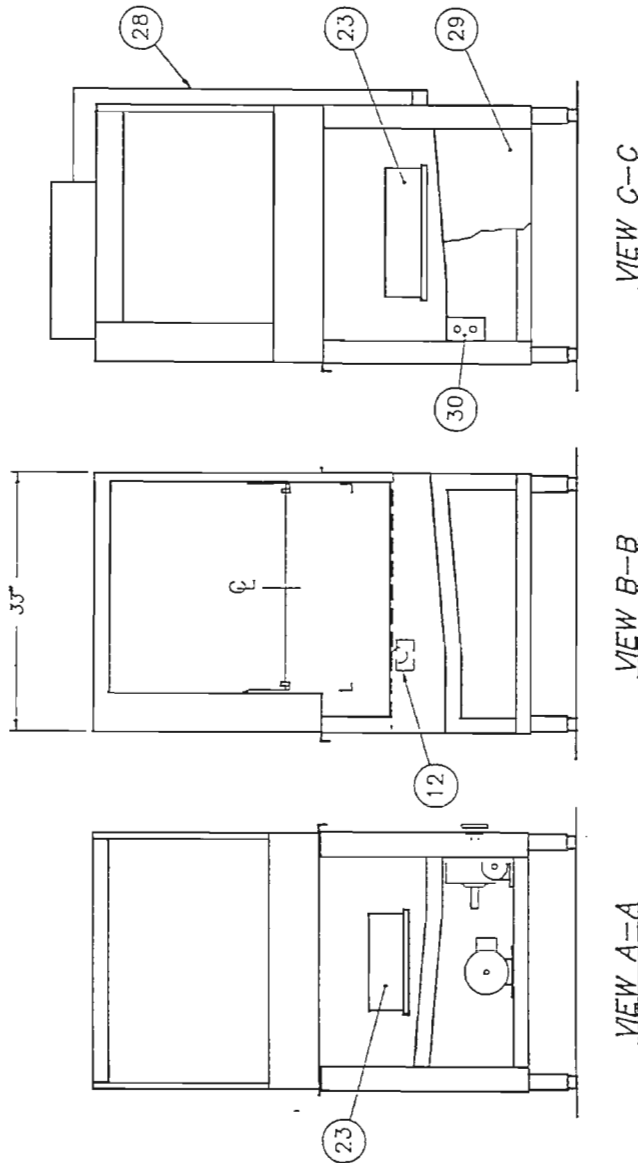

SHEET 3 OF 3

REV	ECN NO	DATE	FILE: PARTS\1462-1	TOLERANCES:	TITLE	DEFENDER	NEXT ASSY DWG. NO.
				FRACTIONS ±1/84	MATL	R.H. MACHINE	REQD 1462-1
				DECIMALS ±.005			SCALE
				XXX ±.01			USED ON
				ANGLES ±1/2°			1=16
				UNLESS OTHERWISE SPECIFIED			DRWN/DATE
							YC 2.26.97
				Philadelphia, PA 19135 (215) 824-4800 FAX (215) 824-6888			

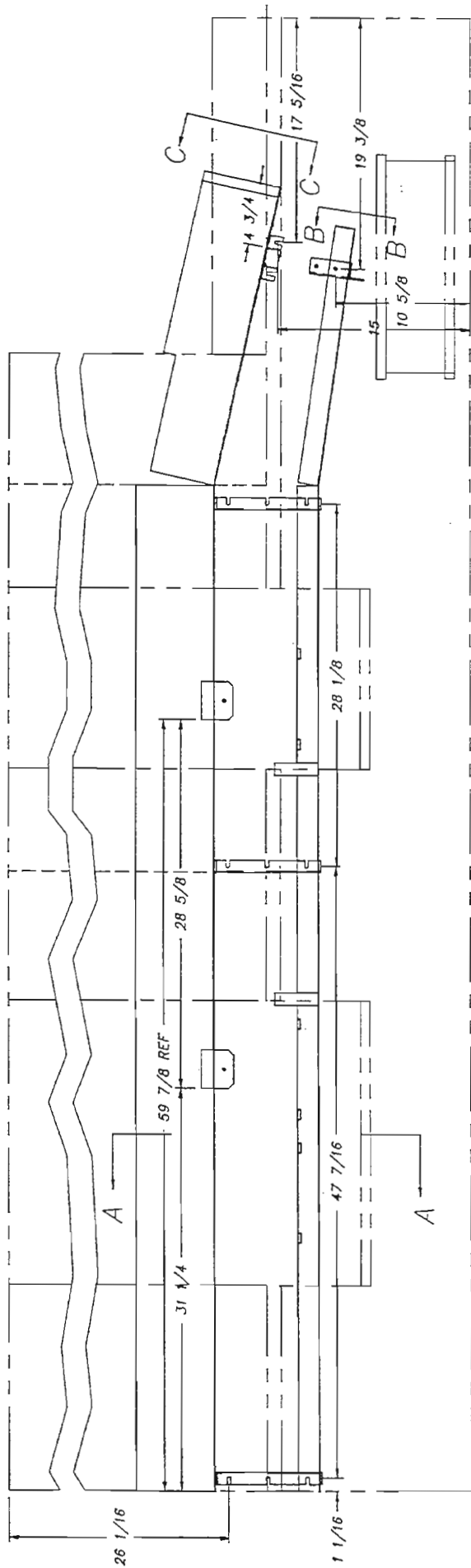

33 INSIDE OF TANK REF.

FRONT

REAR

SECTION B-B

SCALE: 1=4

R.H. MACHINE SHOWN

SHEET 1 OF 3

TOLERANCES	±1/64	FRACIONS	±1/64	TRACIONS	±1/64	DECIMALS	±.005	ANGLES	±1/2°	OTHERWISE	SPECIFIED
REV	ECN NO	DATE	FILE: PARTS\1462-4	REV	1	SCALE	1=8	USED ON	DEFENDER	PC	2.21.97
TITLE			TRACK INSTALLATION	LOAD SECTION		NOTED		 Philadelphia, PA 19135 (215) 824-4800 FAX (215) 824-6888			
NEXT ASSY/DWG. NO.			1462-4	MATERIAL		MATERIAL		R.H. MACHINE SHOWN SHEET 1 OF 3			

ITEM	PART NO.	SIZE	DESCRIPTION	QTY.
1	1462-39	B	TRACK LOWER -- FRONT	1
2	1462-39	B	TRACK LOWER -- REAR	1
3	1462-36	B	TRACK UPPER -- FRONT	1
4	1462-36	B	TRACK UPPER -- REAR	1
5	1100-50	B	TRACK SUPPORT	3
6	1100-50A	A	SHIM	6
7	1100-55	B	TRACK SUPPORT UPPER	1
8	1100-152	A	TRACK SUPPORT LOWER -- REAR	1
9	1462-6	A	TRACK SUPPORT LOWER -- FRONT	1
10	1100-58	A	SUPPORT BAR INSTALLATION	6
11	1390-70	A	CRADLE SUPPORT	4

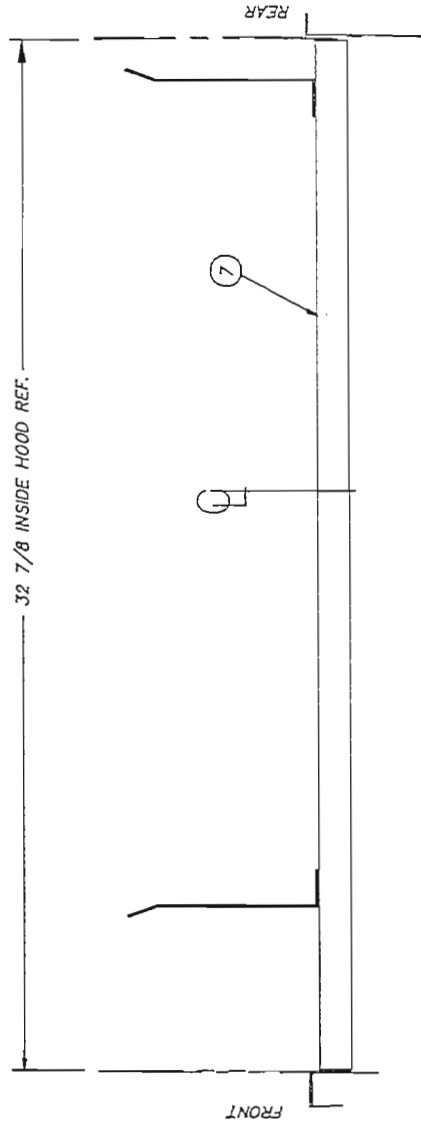
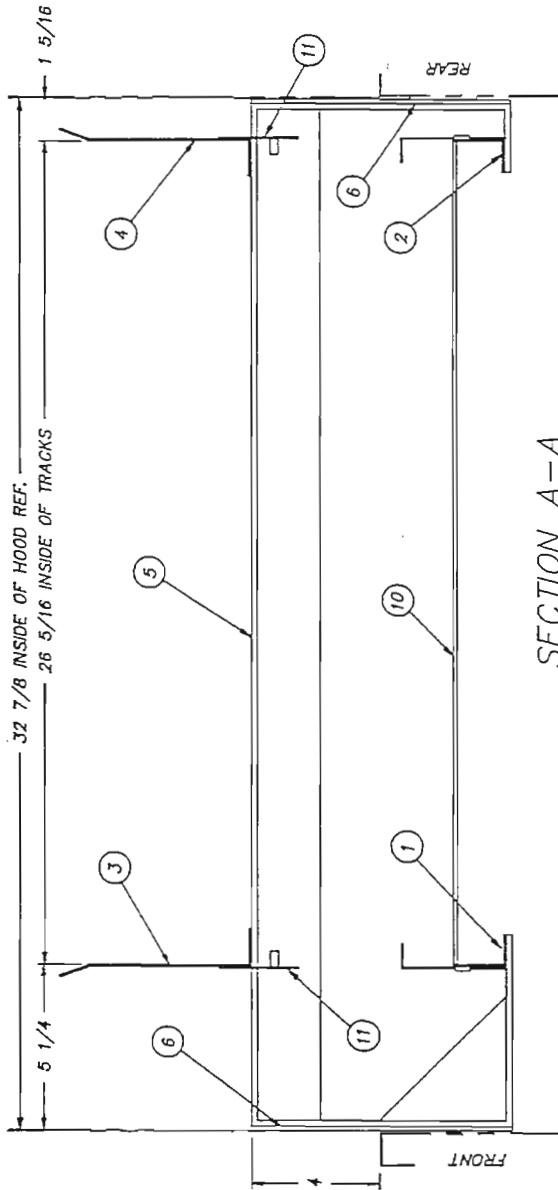

R.H. MACH. SHOWN L.H. MACH. OPPOSITE SHEET 2 OF

TOLERANCES	TITLE	NEXT ASSY DWG. NO.
FRACTIONS ±1/64	TRACK INSTALLATION	REQ'D 1 1462-4
DECIMALS ±.005	LOAD SECTION	SCALE 1=8
XXX ±.01	MATL	USED ON DEFENDER
XX ±.01	NOTED	1=8
ANGLES ±1/2°	INSDNGER	PHILADELPHIA, PA 19135
UNLESS OTHERWISE SPECIFIED	Machine Company	(215) 824-4800
		FAX (215) 824-8888
REV EGN NO DATE		DRWN/DATE
FILE: PARTS\1462-4		PG 7.3.98

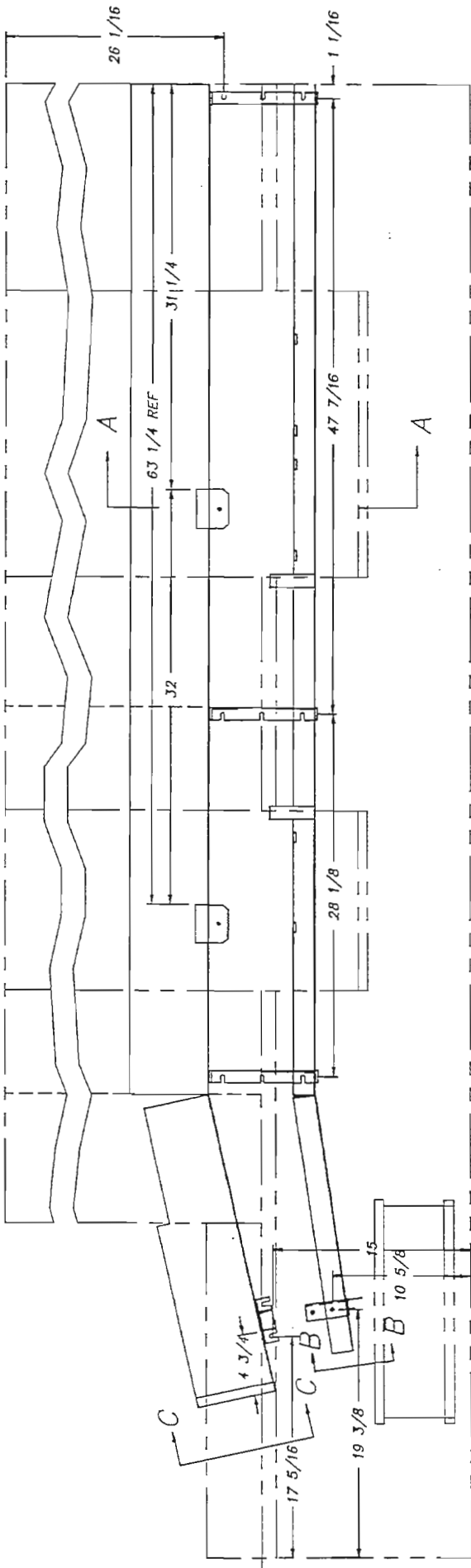

33 INSIDE OF TANK REF.

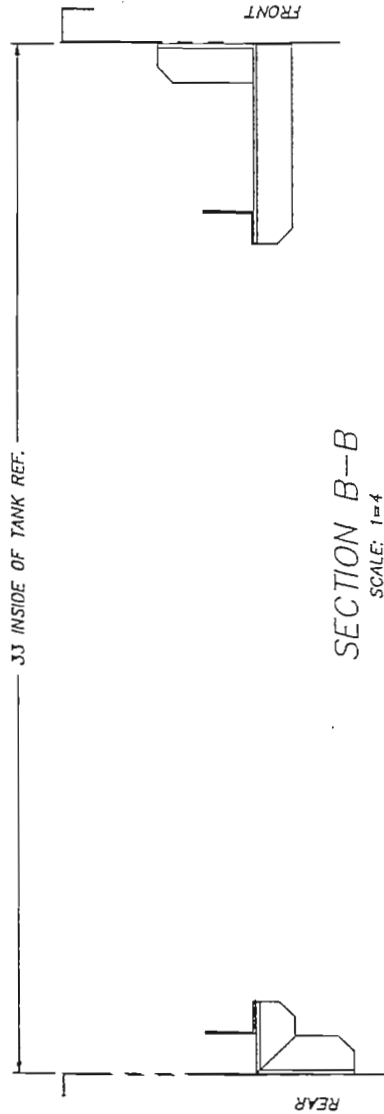

SECTION B-B
SCALE: 1=4

L.H. MACHINE SHOWN

SHEET 3 OF 3

TOLERANCES	TITLE	TRACK INSTALLATION	NEXT ASSY/DWG. NO.
FRACTIONS ±1/64	LOAD SECTION	REQD 1	1462-4
DECIMALS ±.005	MATL	SCALE 1=8	USED ON
.XXX ±.01	NOTED	DEFENDER	1-8
.XX ±.01		DRWR/DATE	
ANGLES ±1/2°		PG	
UNLESS OTHERWISE SPECIFIED			
REV	ECN NO	DATE	
FILE:PARTS\1462-4			

Insinger
Machine Company
Philadelphia, PA 19135
(215) 624-4600
FAX (215) 624-8866

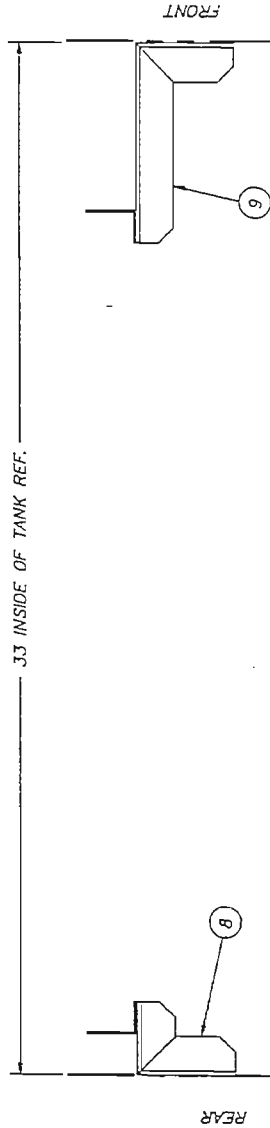
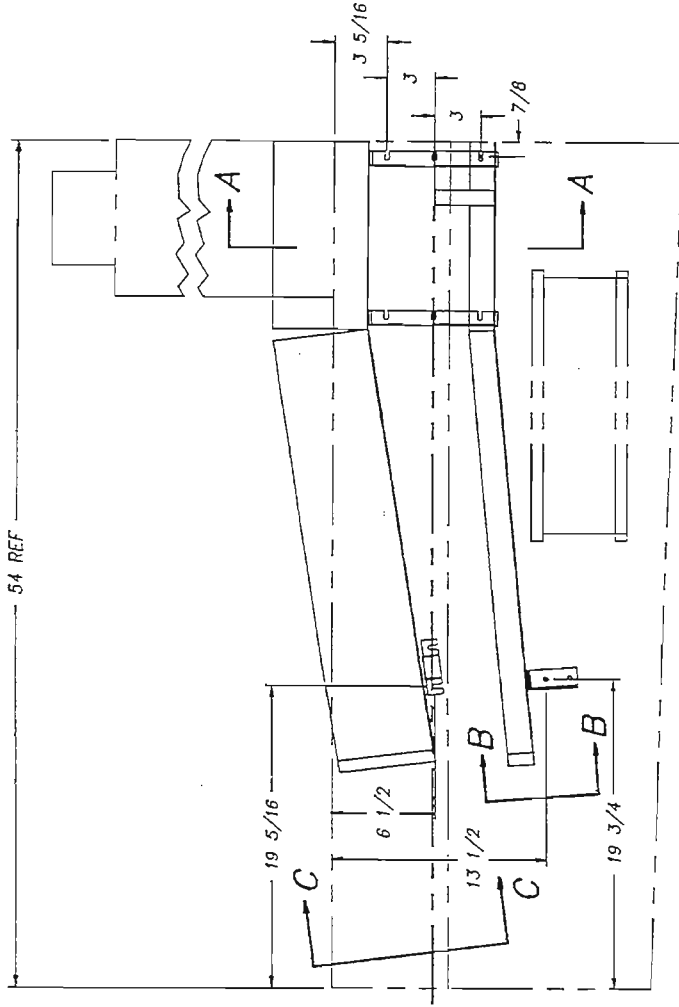

33 INSIDE OF TANK REF.

R.H. SHOWN L.H. OPPOSITE SHEET 1 OF 2

TOLERANCES	TITLE	TRACK INSTALLATION	NEXT ASSY DWG. NO.
FRACTIONS ±1/64	4'-6" UNLOAD SECTION	REQD 1	1462-74
DECIMALS .XXX ± .005	MATL	SCALE	USED ON
.XX ± .01	NOTED	1=8	DEFENDER
ANGLES ±1/2°			DRWR/DATE
UNLESS OTHERWISE SPECIFIED			CES
REV	ECN NO.	DATE	FILE: PARTS\1462-74

SECTION B-B
SCALE: 1=4

Insigner
Machine Company
Philadelphia, PA 19135
(215) 624-4800
FAX (215) 624-8886

ITEM	PART NO.	SIZE	DESCRIPTION	QTY.
1	1462-76	B	TRACK LOWER - FRONT	1
2	1462-76	B	TRACK LOWER - REAR	1
3	1462-75	D	TRACK UPPER - FRONT	1
4	1462-75	D	TRACK UPPER - REAR	1
5	1100-50	B	TRACK SUPPORT	2
6	1100-50A	A	SHIM	4
7	1100-55	B	TRACK SUPPORT UPPER	1
8	1100-152	A	TRACK SUPPORT LOWER REAR	1
9	1100-56	A	TRACK SUPPORT LOWER FRONT	1

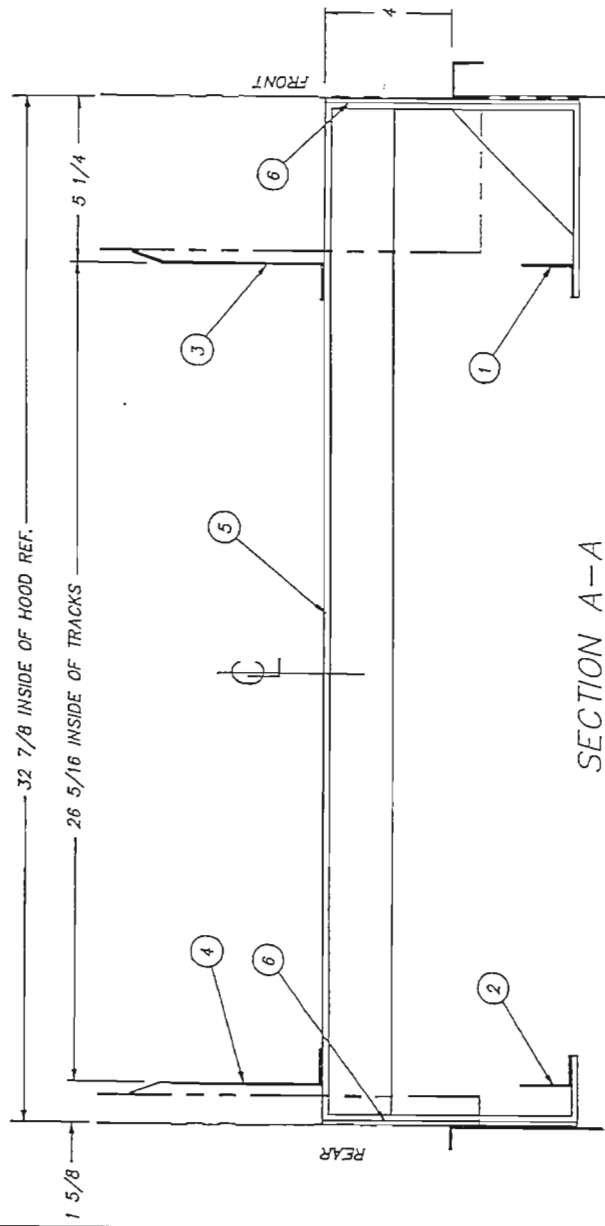

SECTION A-A
SCALE: 1=4

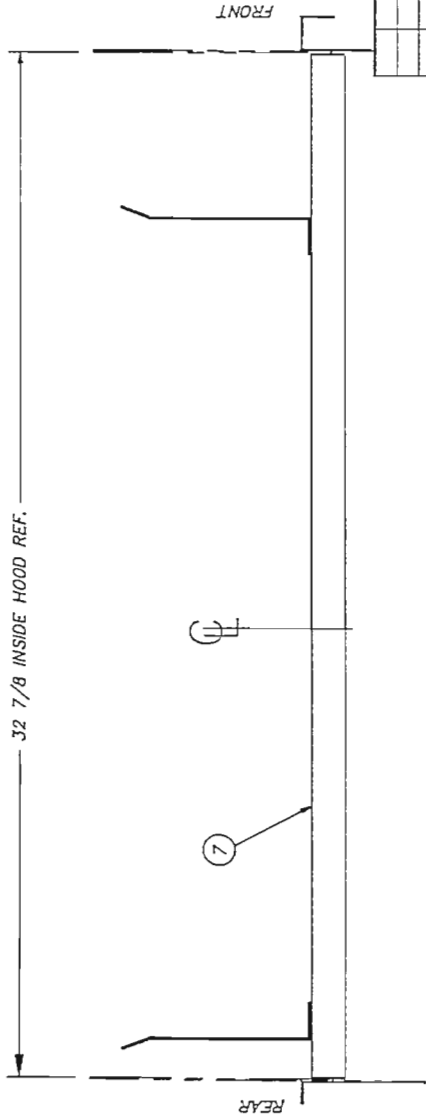

SECTION C-C
SCALE: 1=4

R.H. SHOW L.H. OPPOSITE

TOLERANCES	TITLE	TRACK INSTALLATION	NEXT ASSY/DWG. NO.
FRACTIONS ±1/64	4'-6" UNLOAD SECTION	RECD 1	1462-74
DECIMALS .XXX ±.005	MAT'L	SCALE	USED ON
.XX ±.01	NOTED	1=8	DEFENDER
ANGLES ±1/2°			
UNLESS OTHERWISE SPECIFIED			
REV	ECN NO.	DATE	FILE: PARTS\1462-74

SHEET 2 OF 2

Insinger
Machine Company
Philadelphia, PA 19133
(215) 624-4800
FAX (215) 624-6866
CES

ITEM	PART NO.	SIZE	DESCRIPTION	QTY.
1	1462-43	A	BAFFLE	1
2	1462-44	A	BAFFLE	1
3	1462-45	A	BAFFLE	1
4	1462-46	A	BAFFLE	1
5	1100-61	A	SCRAP SCREEN	4
6	1100-37	A	SCRAP SCREEN	1
7	1462-47	B	SCRAP SCREEN	1

ITEM	PART NO.	SIZE	DESCRIPTION	QTY.
8	1462-48	B	SCRAP SCREEN	1
9	1462-49	A	SUPPORT RAIL	1
10	D309C-GP-06	-	WELDSTUD 1/4 X 3/4 LG.	6
11	1462-33	B	RINSE PAN	1
12	1462-79	A	BAFFLE-RINSE PAN	1

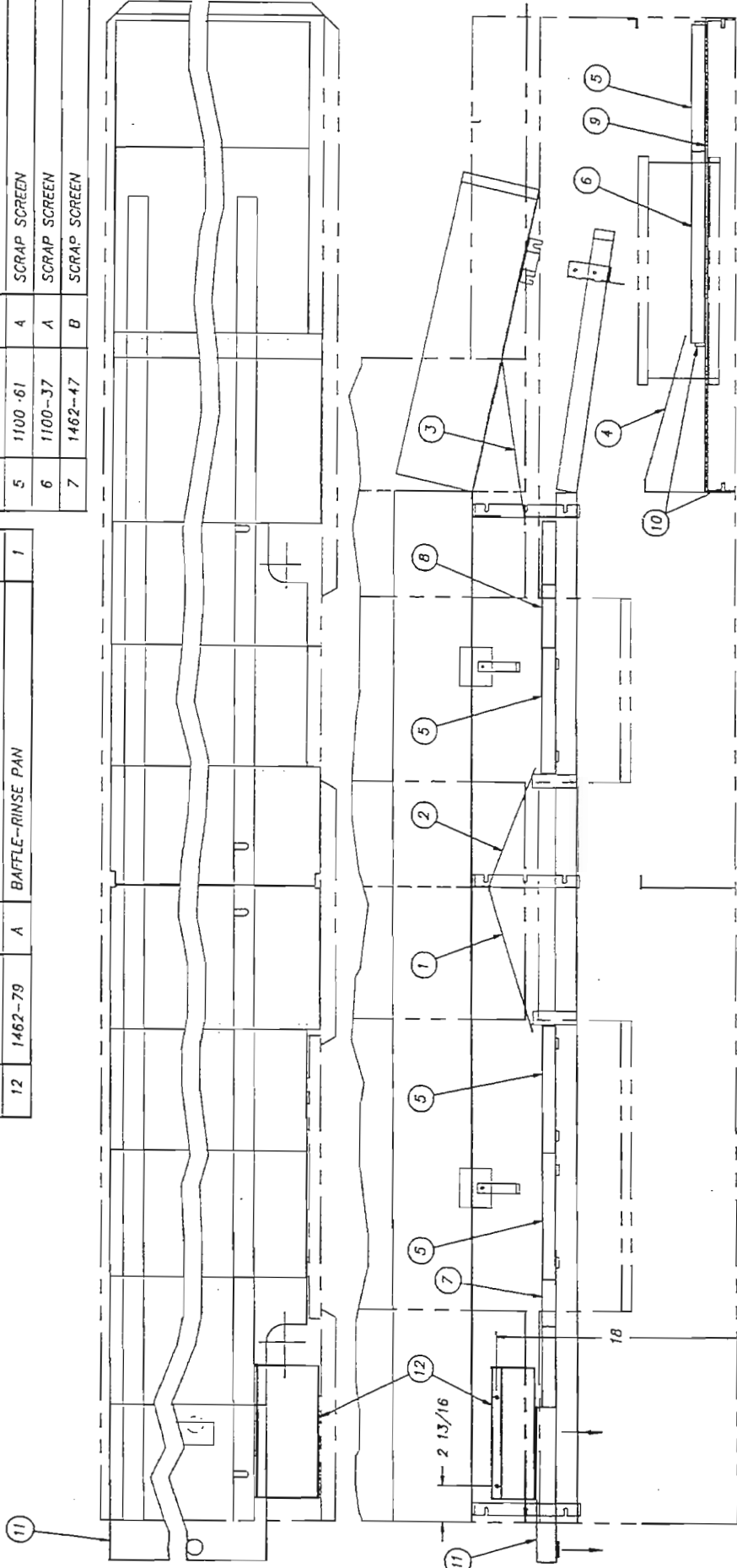

R.H. MACH. ONLY

SHEET 1 OF 2

TOLERANCES	FRACTIONS ±1/64	DECIMALS	XXX ±.005	XX ±.01	XX ±.01	ANGLES ±1/2°	UNLESS OTHERWISE SPECIFIED
TITLE	BAFFLES & SCRAP SCREEN		LOAD SECTION	REQ'D	1	SCALE	1-B
MAT'L	NOTED		PHILADELPHIA, PA 19133	DRWN/DATE	PC	7.8.98	
REV	ECN NO	DATE	insinger		Machine Company		FAX: (215) 824-8868
FILE: PARTS/1462-7			NEXT ASSY Dwg. No.		1462-7		USED ON DEFENDER

ITEM	PART NO.	SIZE	DESCRIPTION	QTY.
8	1462-49	A	SUPPORT RAIL	1
9	0309C-GP-6G	-	WELDSTUD 1/4 X 3/4 LG.	6
10	1462-33	B	RINSE PAN	1
11	1462-79	A	BAFFLE-RINSE PAN	1

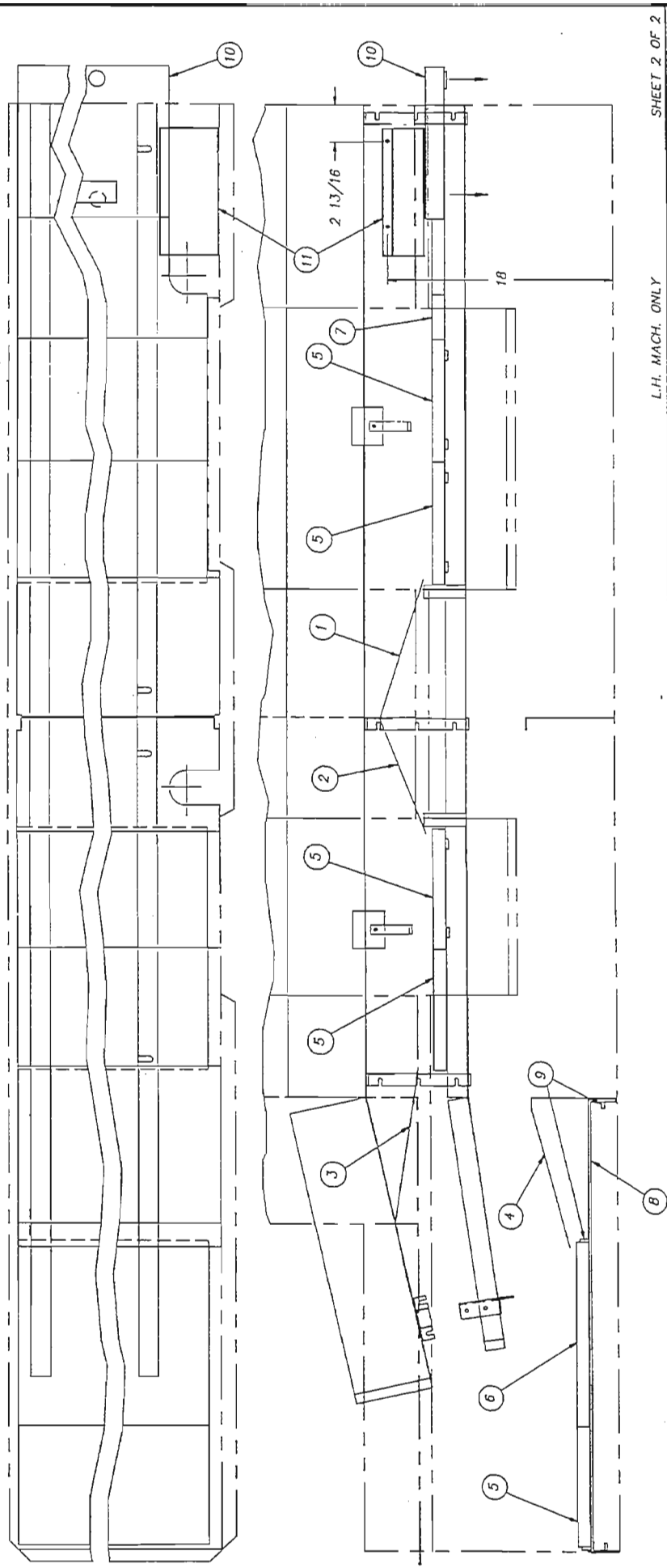

ITEM	PART NO.	SIZE	DESCRIPTION	QTY.
1	1462-43	A	BAFFLE	1
2	1462-50	A	BAFFLE	1
3	1462-45	A	BAFFLE	1
4	1462-46	A	BAFFLE	1
5	1100-61	A	SCRAP SCREEN	5
6	1100-37	A	SCRAP SCREEN	1
7	1462-47	B	SCRAP SCREEN	1

L.H. MACH. ONLY

SHEET 2 OF 2

TOLERANCES:	TITLE	SCALE	USED ON
FRACTIONS ±1/64	BAFFLES & SCRAP SCREEN	1	DEFENDER
DECIMALS .XXX ±.005	LOAD SECTION	1	DEFENDER
.XX ±.01		1=0	DEFENDER
ANGLES ±1/2°			
UNLESS OTHERWISE SPECIFIED			
REV	ECN NO.	DATE	DRWN/DATE
			PG
FILE: PARTS/1462-7		PG 7.8.96	

InSinger
 Machine Company
 Philadelphia, PA 19135
 (215) 624-4800
 FAX (215) 624-6968

ITEM	PART NO.	SIZE	DESCRIPTION	QTY.
1	1390-53-1	A	TOP BAFFLE	1
2	1390-54	A	TOP BAFFLE	2
3	1390-52	A	SIDE BAFFLE	1
4	D-761B	A	CURTAIN ROD CLIP	8
5	D2-522-1	A	SPLASH GUARD CURTAIN (16") CENTER	2
6	D2-522-2	A	SPLASH GUARD CURTAIN (12") CENTER	1
7	D2-522-3	A	SPLASH GUARD CURTAIN (10 1/2") CENTER	1

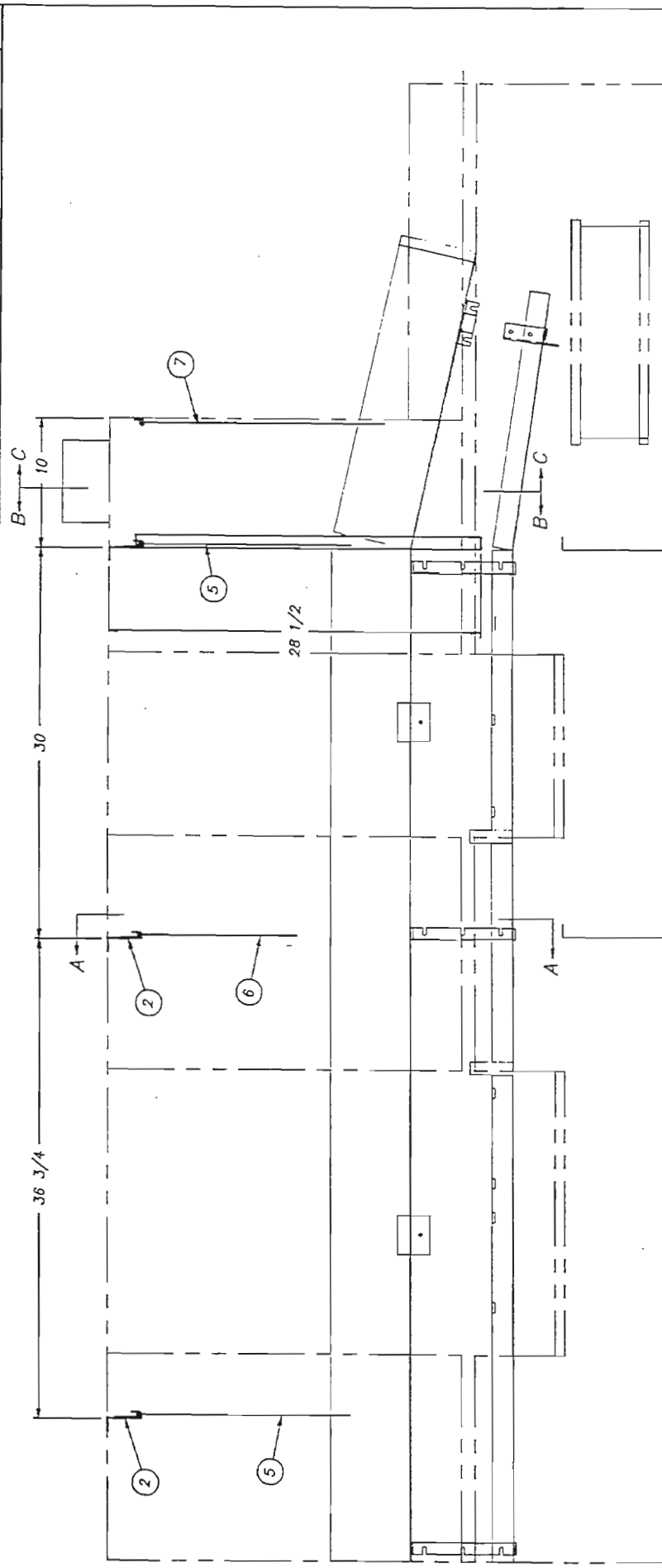

R.H. MACH. SHOWN L.H. MACH. OPPOSITE		SHEET 1 OF 2	
TOLERANCES	FRACTIONS ±1/64	TITLE	CURTAIN & BAFFLE INSTALL.
	DECIMALS	REQ'D	1
	.XX ± .005	SCALE	1462-9
	.XX ± .01	MAT'L	NOTED
	ANGLES ±1/2°	USED ON	DEFENDER
	OTHERWISE SPECIFIED	DRWN/DATE	PC
REV	ECH NO	DATE	
FILE: PARTS/1462-9			

NOTE:
1. SEE DWG. D-761D & 1100-322
FOR PRISON PACKAGE.

insinger
Machine Company
Philadelphia, PA 19135
(215) 824-4800
FAX (215) 824-8888

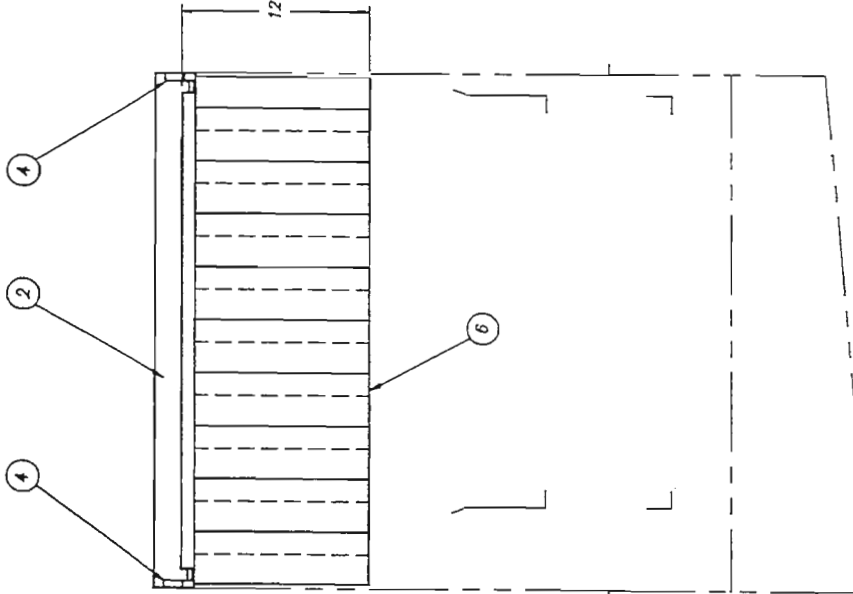

SECTION A-A

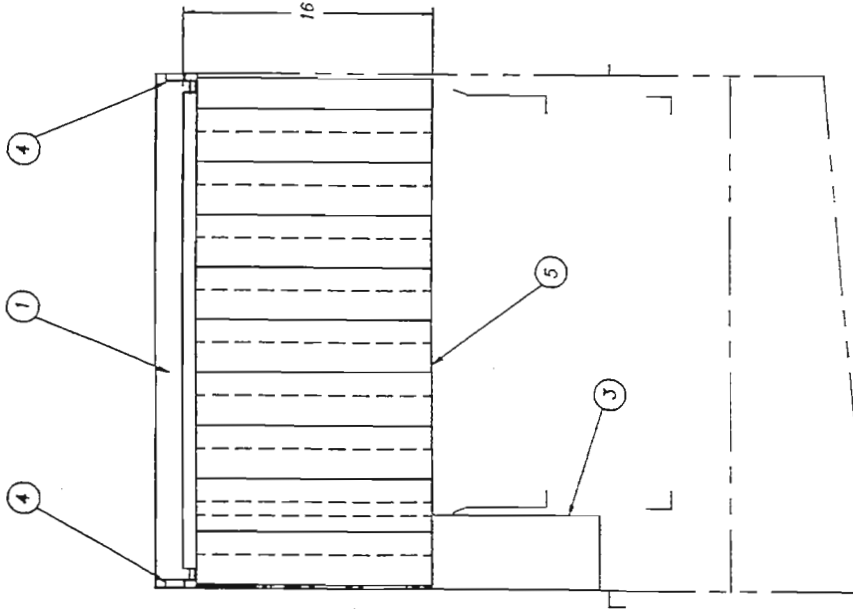

SECTION B-B

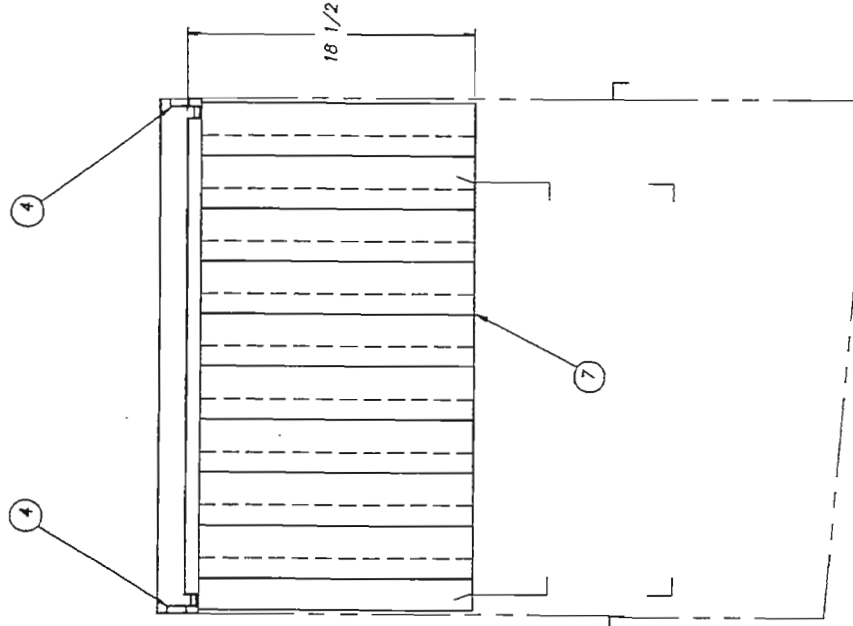

SECTION C-C

R.H. MACH. SHOWN		L.H. MACH. OPPOSITE		SHEET 2 OF 2	
TOLERANCES		TITLE		NEXT ASSY DWG. NO.	
FRACTIONS ±1/64		CURTAIN & BAFFLE INSTALL		REQ'D	1462-9
DECIMALS		LOAD SECTION		SCALE	1-8
.XXX ± .003		NOTED		USED ON	DEFENDER
.XX ± .01				DRRR/DATE	PC 2.24.97
ANGLES ±1/2°					
UNLESS OTHERWISE SPECIFIED					
REV	ECN NO	DATE	FILE: PARTS/1462-9		

NOTE:
1. SEE DWG. D-761D & 1100-322 FOR PRISON PACKAGE.

Insinger
Machine Company
Philadelphia, PA 19135
(215) 824-4800
FAX (215) 824-8988

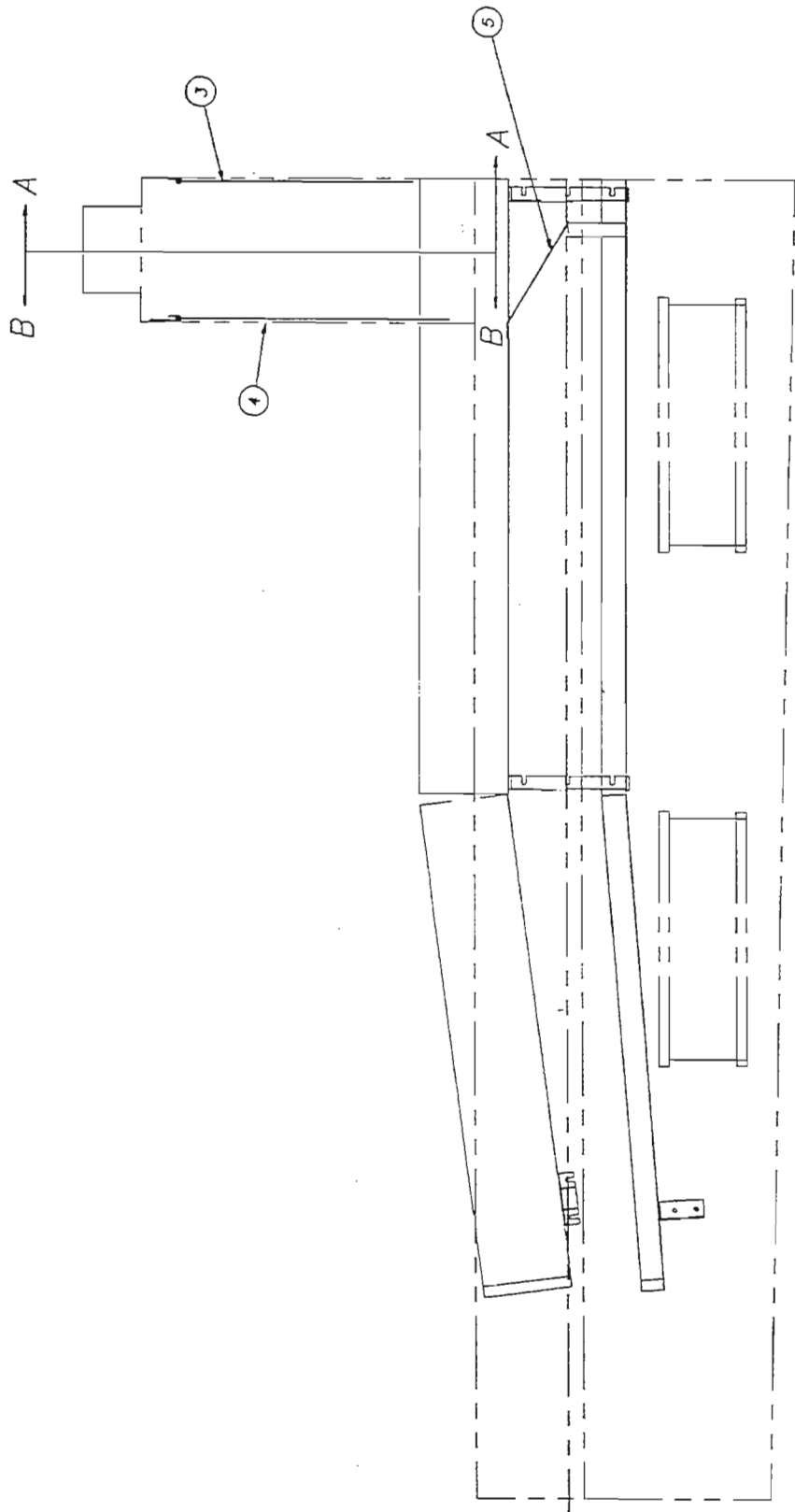

R.H. SHOWN L.H. OPPOSITE		SHEET 1 OF 2	
TOLERANCES	FRACIONS ±1/64	TITLE	CURTAIN INSTALLATION
	DECIMALS .XXX ±.005	REQ'D	1
	.XX ±.01	SCALE	1=8
	ANGLES ±1/2°	USED ON	DEFENDER
UNLESS OTHERWISE SPECIFIED		DRWN/DATE	PC
REV	ECH NO	DATE	
FILE: PARTS/1462-10			
Machine Company		Philadelphia, PA 19133 (215) 824-4800 FAX (215) 824-8868	
		Insinger Machine Company	

ITEM	PART NO.	SIZE	DESCRIPTION	QTY.
1	1390-53-2	A	TOP BAFFLE	1
2	D-761B	A	CURTAIN ROD CLIP	4
3	D2-522-1	A	SPLASH GUARD CURTAIN (16") CENTER	1
4	D3-526	A	SPLASH GUARD CURTAIN (18 1/2")	1
5	1462-B	A	BAFFLE, UNLOAD SECTION	1

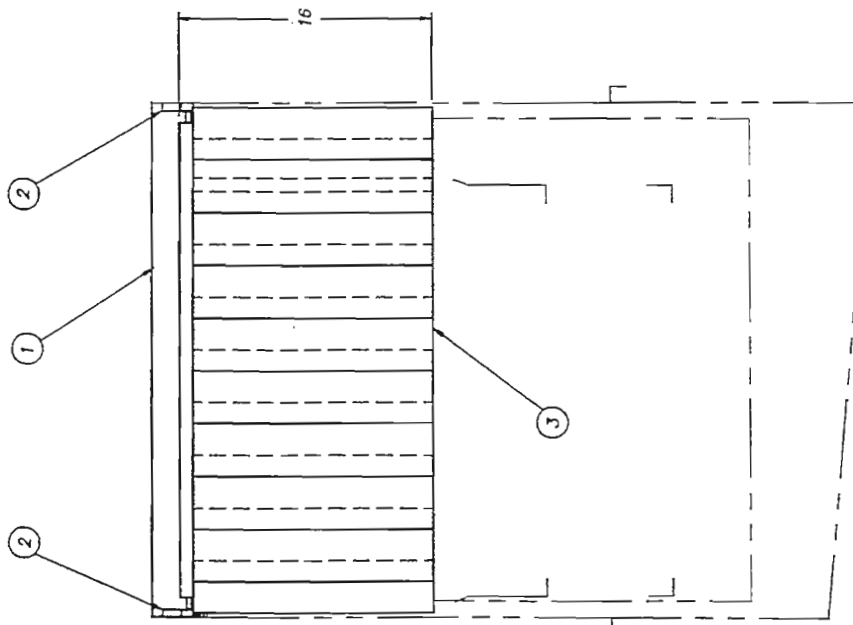

SECTION A-A

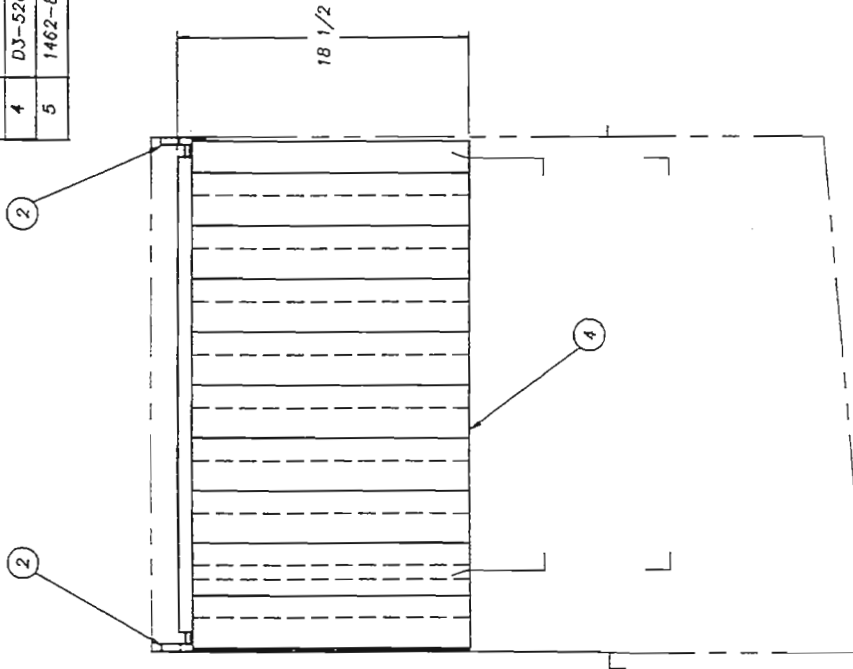

SECTION B-B

NOTE:
1. SEE DWG. D-761D & 1100-322
FOR PRISON PACKAGE.

R.H. MACH. SHOWN L.H. MACH. OPPOSITE

SECTION B-B

SECTION A-A

SHEET 2 OF 2

TOLERANCES		TITLE		NEXT ASSY DWG. NO.	
FRACCTIONS ±1/64		CURTAIN INSTALLATION	REQ'D	1	1462-10
DECIMALS .005		UNLOAD SECTION	SCALE	1=B	USED ON DEFENDER
XXX ± .01		MATL	AS NOTED		
ANGLES ±1/2°					
UNLESS OTHERWISE SPECIFIED					
REV. LGN. NO.	DATE	 Insinger Machine Company Philadelphia, PA 19135 (215) 624-4800 FAX (215) 624-8888			
FILE: PARTS/1462-10		PA 10135 (215) 624-4800 PG 2.25.97			

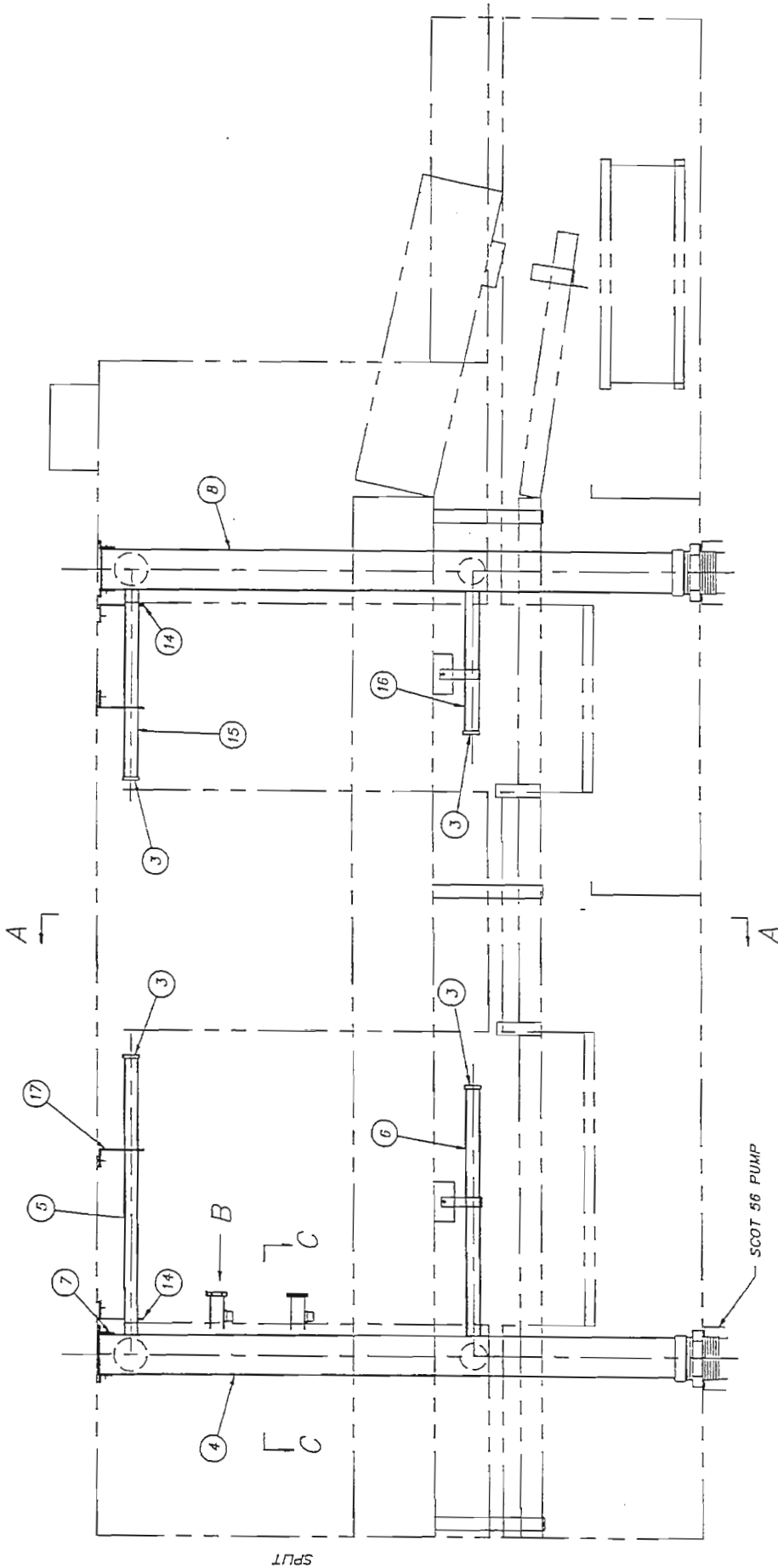

SPLIT

R.H. MACHINE SHOWN

SHEET 1 OF 3

TOLERANCES	FRACIONS ±1/64	NEXT ASSY DWG. NO.	1462-82
	DECIMALS	REQ'D	1
	.XXX ± .003	SCALE	1=8
	.XX ± .01	USED ON	DEFENDER
	ANGLES ±1/2°	ORWR/DATE	CES
	UNLESS OTHERWISE SPECIFIED	FAX (215) 824-8866	1.9.97
REV	ECN NO	DATE	
FILE: PARTS\1462-82			

TITLE DISCHARGE LINE ASSY (LOAD)
W/O SILVERWARE TROUGH

MATL NOTED

Insinger
Machine Company
Philadelphia, PA 19135
(215) 824-4800

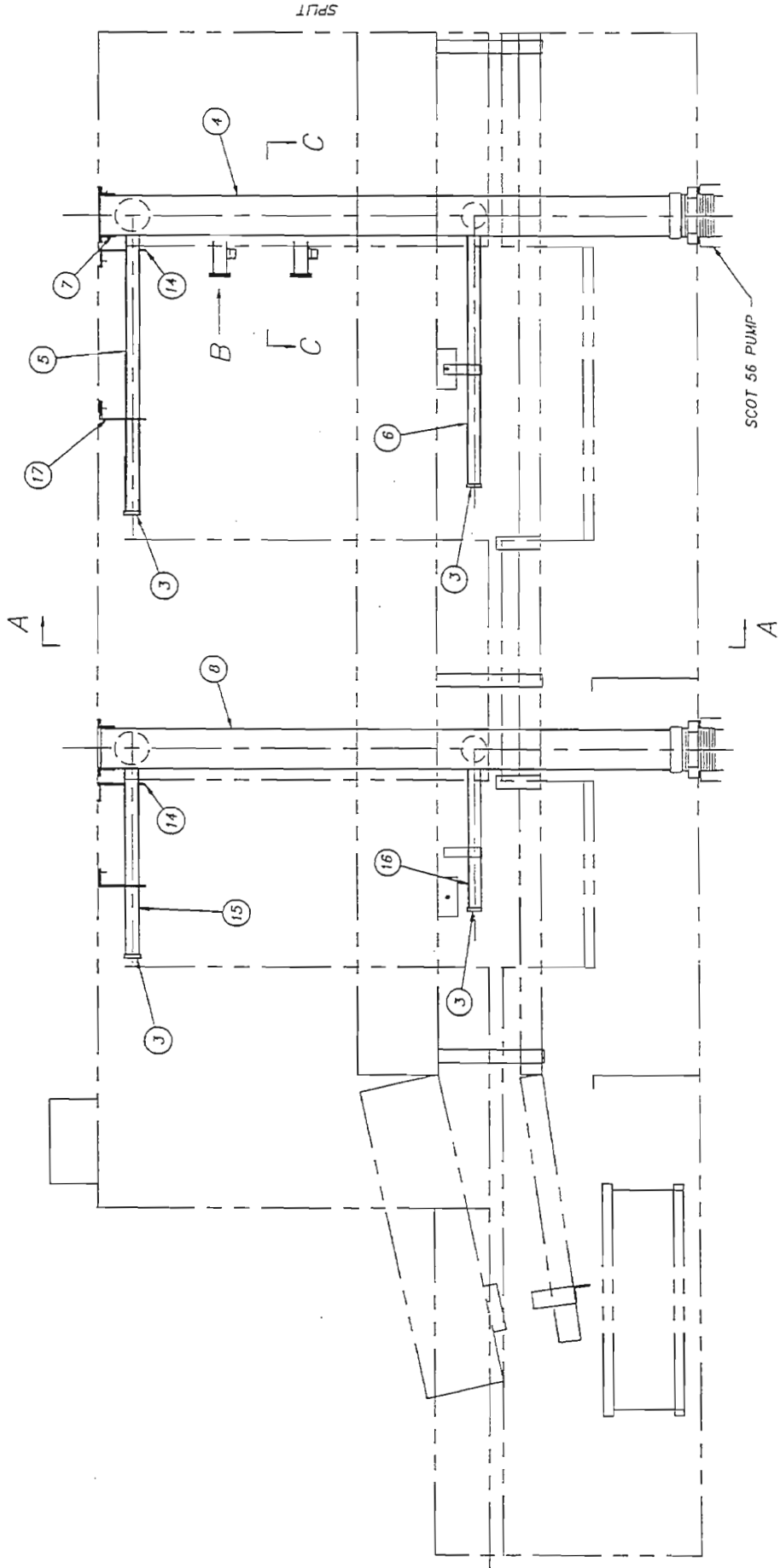

L.H. MACHINE SHOWN		SHEET 2 OF 3	
TOLERANCES	FRACTIONS ±1/64	TITLE	DISCHARGE LINE ASSY (LOAD)
	DECIMALS .XXX ± .005	W/O SILVERWARE TROUGH	
	.XX ± .01	MAT'L	NOTED
	ANGLES ±1/2°	SCALE	1=8
	UNLESS OTHERWISE SPECIFIED	USED ON	DEFENDER
REV	ECH NO	DATE	
FILE: PARTS\1462-82			
Insinger Machine Company		Phoenopolis, PA 19135	
		(215) 624-4800	
		FAX (215) 624-6966	
		CES	
		1.9.97	

NEXT ASSY DWG. NO.	1462-82
REQ'D	1

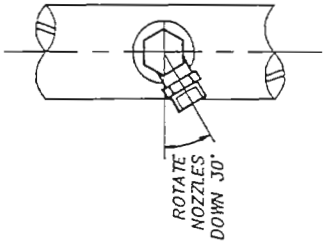
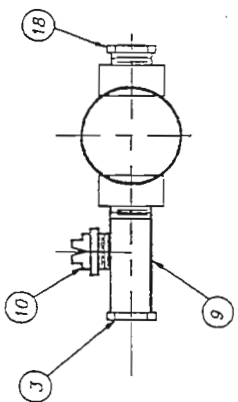
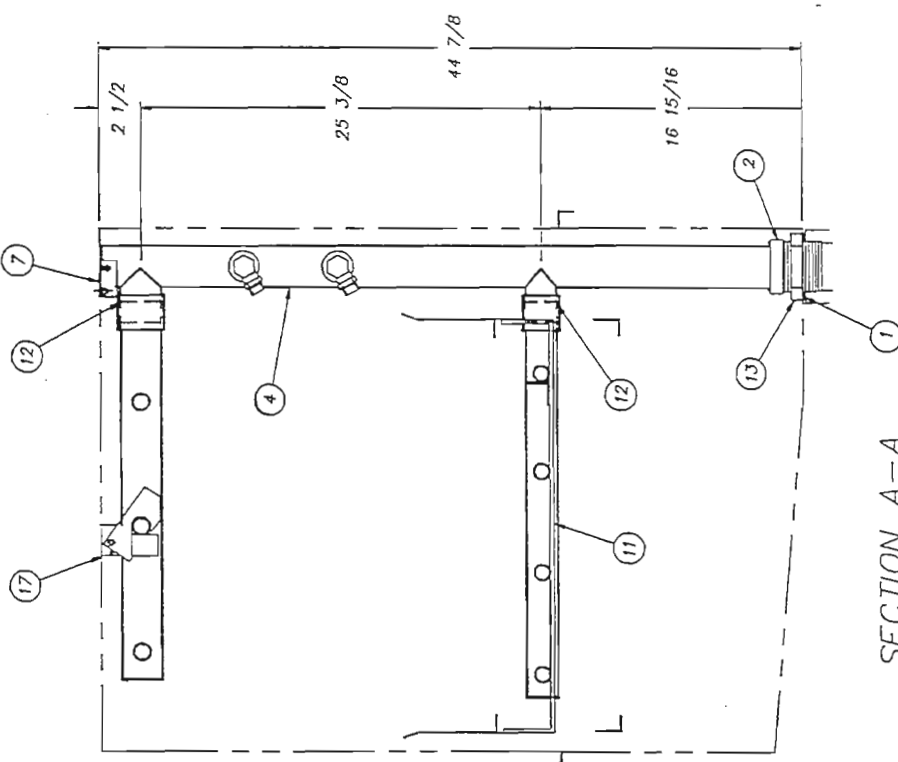

ITEM	PART NO.	DESCRIPTION	QTY.
1	1104-67	GASKET, PUMP DISCHARGE	1
2	1104-65	NIPPLE, DISCHARGE LINE	1
3	D2-554-3	PLUG 7/8-9 UNC-2A	16
4	1462-81	DISCHARGE TUBE-WASH (3" OD)	1
5	1462-34	MANIFOLD ASSY-UPPER WASH	1
6	1462-35	MANIFOLD ASSY-LOWER WASH	1
7	1169-96	SUPPORT INSTALLATION	2
8	1462-80	DISCHARGE TUBE-PW (3" OD)	1
9	1162-94	EXTENSION MANIFOLD	2
10	D2272	SPRAY NOZZLE #80-200	2
11	1390-59	GRADLE-SPRAY PIPE	2
12	D2-564	"O" RING (01-032)	2
13	D326F-11	LOCKNUT	2
14	SK-3733	STOP BRACKET	2
15	1462-56	MANIFOLD ASSY-UPPER PWASH	1
16	1462-57	MANIFOLD ASSY-LOWER PWASH	1
17	D-2349	LATCH ASSEMBLY-SPRAY PIPE	2
18	D328F-F2-C	HEX PLUG 3/4 IPS	2

SECTION A-A

L.H. WASH TANK SHOWN

SHEET 3 OF 3

TOLERANCES	NEXT ASSY	OWG. NO.
FRACTIONS ±1/64	TITLE DISCHARGE LINE ASSY (LOAD)	REQD 1
DECIMALS	W/O SILVERWARE TROUGH	SCALE 1462-82
.XXX ± .005	MATL	USED ON
.XX ± .01	NOTED	DEFENDER
ANGLES ±1/2°	INSINGER	DRWR/DATE
UNLESS OTHERWISE SPECIFIED	Philadelphia, PA 19135	CES
REV	ECN NO.	DATE
FILE: PARTS\1462-82	Machining Company	FAX (215) 624-6988



PART 5
REPLACEMENT PARTS
FOR DEFENDER SERIES

ITEM	PART NO.	SIZE	DESCRIPTION	QTY.
1	1100-3190	B	FINAL RINSE INSIDE PIPING	1
2	875-100	A	BRACKET	2
3	D309C-EF-3G	--	WELDSTUD 10-32 X 3/8	2
4	D312C-EF-5	--	LOCKNUT 10-32	2
5	D314F-EL-12	--	NIPPLE 3/4 IPS X 1 1/2 L.O.E.	1
6	D326F-E1	--	LOCKNUT 3/4 IPS	1
7	D320F-E1E301	--	TEE 3/4 IPS X 3/4C X 1/2 IPS	1
8	D326F-D2-A	--	PIPE PLUG 1/2 IPS	1
9	1462-84	B	SPRAY PIPE, LOWER	1
10	D-2036	--	SPRAY NOZZLE 1/4 IPS	9
11	D2-554-2	A	PLUG 3/4-10 UNC-2A	2
12	D207A-B6-22	--	COP. TUBE 3/4 CTS X 5 1/2	1
13	D-2243	--	VACUUM BREAKER 3/4 IPS	1
14	D314F-ES-16	--	NIPPLE 3/4 IPS X 2	1
15	D316F-E3-E1	--	90° ELL 3/4 C X 3/4 FPS	1
16	D2390SP-1	--	BRASS UNION	1
17	D2390SP	--	SPLIT JAM NUT	1
18	D318A-E3-E2	--	COPPER UNION 3/4 C X 3/4 HPS	1
19	D-2597	--	SOLENOID (WATER) 3/4 IPS	1
20	D314F-EC-00	--	CLOSE NIPPLE 3/4 IPS	2
21	D320F-E1E1E1	--	TEE 3/4 IPS	1
22	D322F-E2-B1	--	HEX RED 3/4 MIPX X 1/4 FPS	1
23	D-2497	--	PETCOCK 1/4 IPS	1
24	SK-1433	A	PRESSURE GAUGE 1/4 IPS	1
25	1100-329A	B	SPRAY PIPE, UPPER X 27 3/4	1

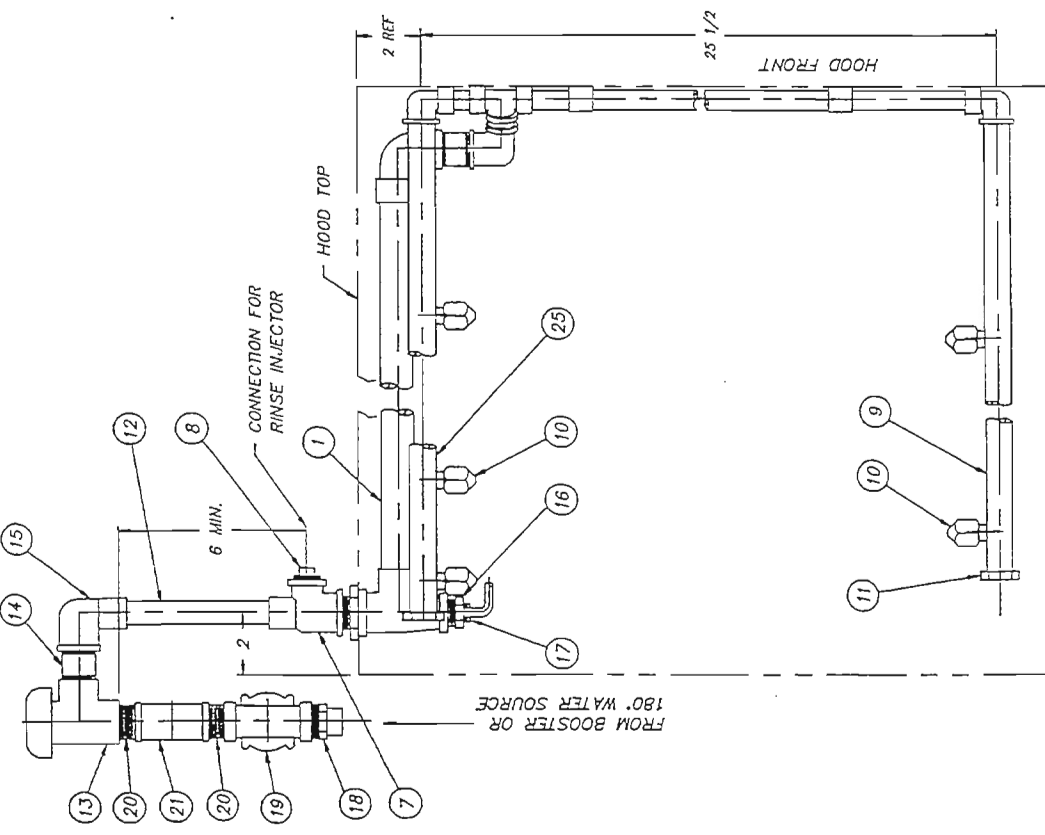
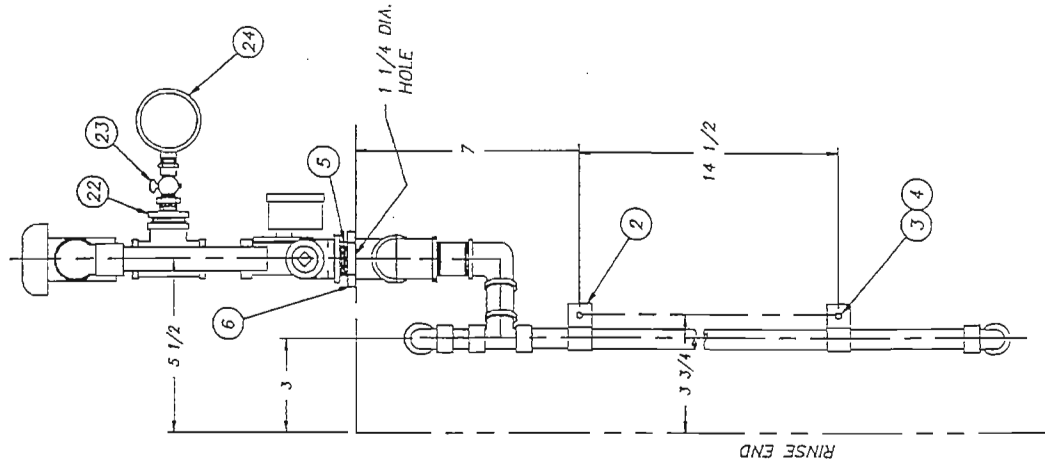

R.H. SHOWN L.H. OPPOSITE		NEXT ASSY DWG. NO.	
TITLE		FINAL RINSE ASSEMBLY	REQ'D 1
MATERIAL		NOTED	SCALE 1=4
TOLERANCES		USED ON DEFENDER	
FRAGMENTS ±1/64	DECIMALS ±.005	DRWN/DATE	
XX ±.01	ANGLES ±1/2°	CES	
UNLESS OTHERWISE SPECIFIED		2.20.97	
REV	ECN NO	DATE	
FILE: PARTS\1462-59			

INSINGER Machine Company
 Philadelphia, PA 19133
 (215) 624-4800
 FAX: (215) 624-8968

• DENOTES NICKEL PLATED

ITEM	PART NO.	SIZE	DESCRIPTION	QTY.
1	D328F-D1	-	LOCKNUT 1/2 IPS	3
2	D314F-DL-52	-	NIPPLE 1/2 IPS X 6 1/2 L.O.E.	3
3	D316F-D1-D2	-	90° STREET ELL 1/2 IPS	6
4	D-2241	-	VACUUM BREAKER 1/2 IPS	3
5	D314F-DC-00	-	CLOSE NIPPLE 1/2 IPS	6
6	D-2606	-	SOLENOID VALVE 1/2 IPS 24V	3
7	D320F-E1E1D1	-	TEE 3/4IPS X 3/4IPS X 1/2IPS	2
8	D317A-E3-E2	-	ADAPTER 3/4 C X 3/4 MIP	2
9	-	-	-	-
10	D328F-E2-A	-	PIPE PLUG 3/4 IPS	1
11	957-80	A	BRACKET	3
12	D207A-B6-68	-	COPPER TUBING 3/4ACTS X 17	1
13	D315A-D1-D1	-	45° 1/2 FIPS X 1/2 FIPS	2
14	D318A-E3-E	-	UNION 3/4C	1

ITEM	PART NO.	SIZE	DESCRIPTION	QTY.
15	D314F-EG-00	-	CLOSE NIPPLE 3/4 IPS	1
16	D-2482	-	*Y* STRAINER 3/4 IPS	1
17	D328F-D1	-	CAP 1/2 IPS	1
18	D207A-B4-99	-	COPPER TUBING 1/2 CTS X 24 3/4 LG.	1

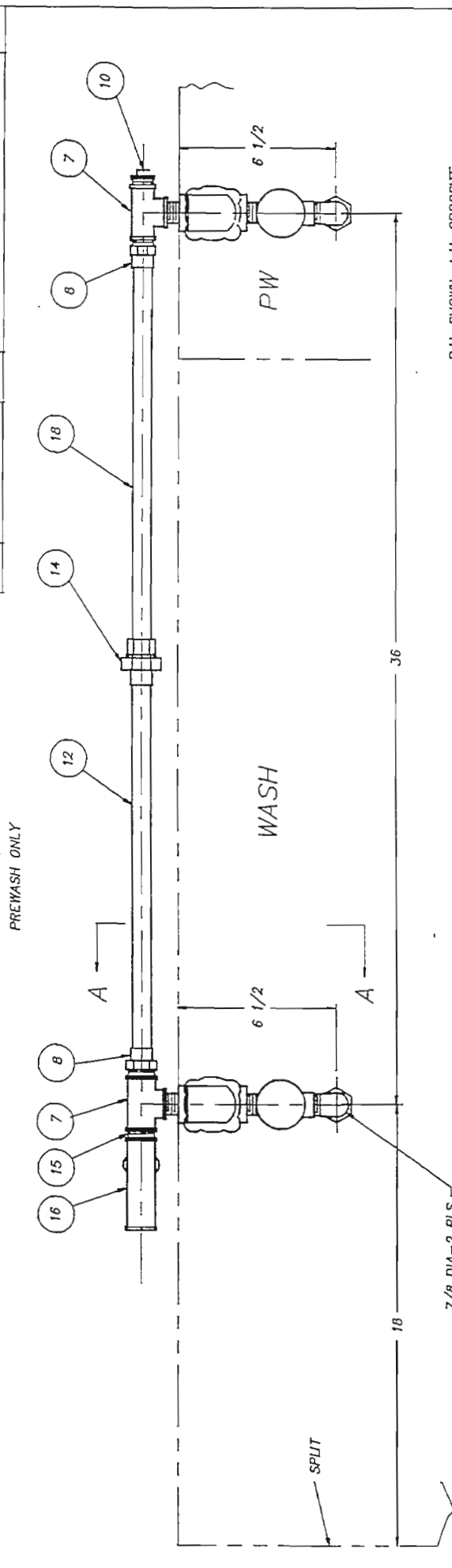
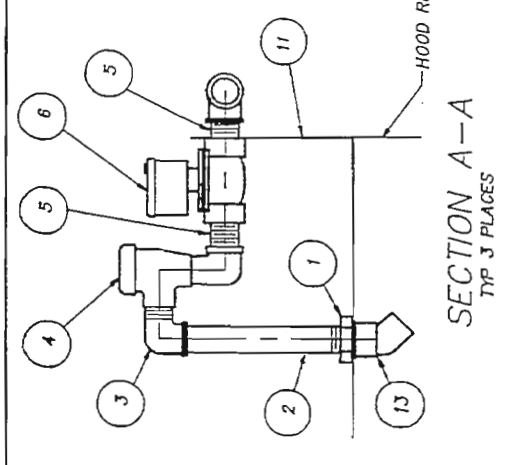

REV	ECN NO	DATE	FILE: PARTS
			1462-60

TOLERANCES	FRACCTIONS ±1/64	DECIMALS	XXX ±.005	XX ±.01	ANGLES ±1/2°	UNLESS OTHERWISE SPECIFIED

R.H. SHOWN L.H. OPPOSITE
 TITLE AUTO TANK FILL ASSEMBLY
 PREWASH & WASH
 RECD 1
 SCALE 1-4
 USED ON DEFENDER
 NEXT ASSY DWG. NO. 1462-60
 Insigner
 Machine Company
 Philadelphia, PA 19135
 (215) 824-4800
 FAX (215) 824-8886
 CES
 R.R.96

ITEM	PART NO.	SIZE	DESCRIPTION	QTY.
1	1104-B1B	A	SPRAY PIPE WELDMENT 3" LOAD	1
2	D-2534	-	SPRAY NOZZLE	3
3	D2-554-1	A	PIPE PLUG 9/16-12 UNC-2A	1
4	D326F-01	-	LOCKNUT 1/2 IPS	1
5	D314F-D1-52	-	NIPPLE 1/2 IPS X 6 1/2 L.O.E.	1
6	D316F-D1-D2	-	90° STREET ELL 1/2 IPS	2
7	D-2241	-	VACUUM BREAKER 1/2 IPS	1
8	D314F-DC-00	-	CLOSE NIPPLE 1/2 IPS	2
9	D-2606	-	SOLENOID VALVE 1/2 IPS 24V	1
10	D320F-D1D1D1	-	TEE 1/2 FIPS X 1/2 FIPS X 1/2 FIPS	1
11	D317A-DJ-D2	-	ADAPTER 1/2 C X 1/2 MIPS	2
12	D328F-D2-A	-	PIPE PLUG 1/2 IPS	2
13	957-80	-	BRACKET	1
14	D207A-B4-24	-	COPPER TUBING 1/2 CTS X 6 LG	2
15	D315A-D1-01	-	45° 1/2 FIPS X 1/2 FIPS	1
16	D318A-DJ-D3	-	UNION 1/2 CTS	1
17	D314F-DC-00	-	CLOSE NIPPLE 1/2 IPS	1
18	D-2483A	-	*Y" STRAINER 1/2 IPS	1
19	-	-	-	-
20	D316F-C1-C1	-	90° ELBOW 3/8 IPS	1
21	D314F-BL-40	-	NIPPLE 1/4 IPS X 5" L.O.E.	1
22	D316F-B1-B2	-	90° STREET EL 1/4 IPS	3
23	D-2438A	-	VACUUM BREAKER 1/4 IPS	1
24	D314F-BS-12	-	NIPPLE 1/4 IPS X 1 1/2 LG	2
25	D-2605	-	SOLENOID VALVE 1/4 IPS 24V	1
26	D322F-C2-B1	-	HEX REDUCER 3/8 MIPS X 1/4 FIPS	2
27	D316F-B1-C5	-	90° ELBOW 1/4 FIPS X 3/8 COMP	1
28	D207A-N3	-	3/8 OD COPPER TUBING X 6 FT LG	1
29	D320F-D1C1D1	-	TEE 1/2 FIPS X 3/8 FIPS X 1/2 FIPS	1
30	D317F-B2-C5	-	ADAPTER 1/4 MIPS X 3/8 COMP	1
31	D326F-B1	-	LOCKNUT 1/4 IPS	1

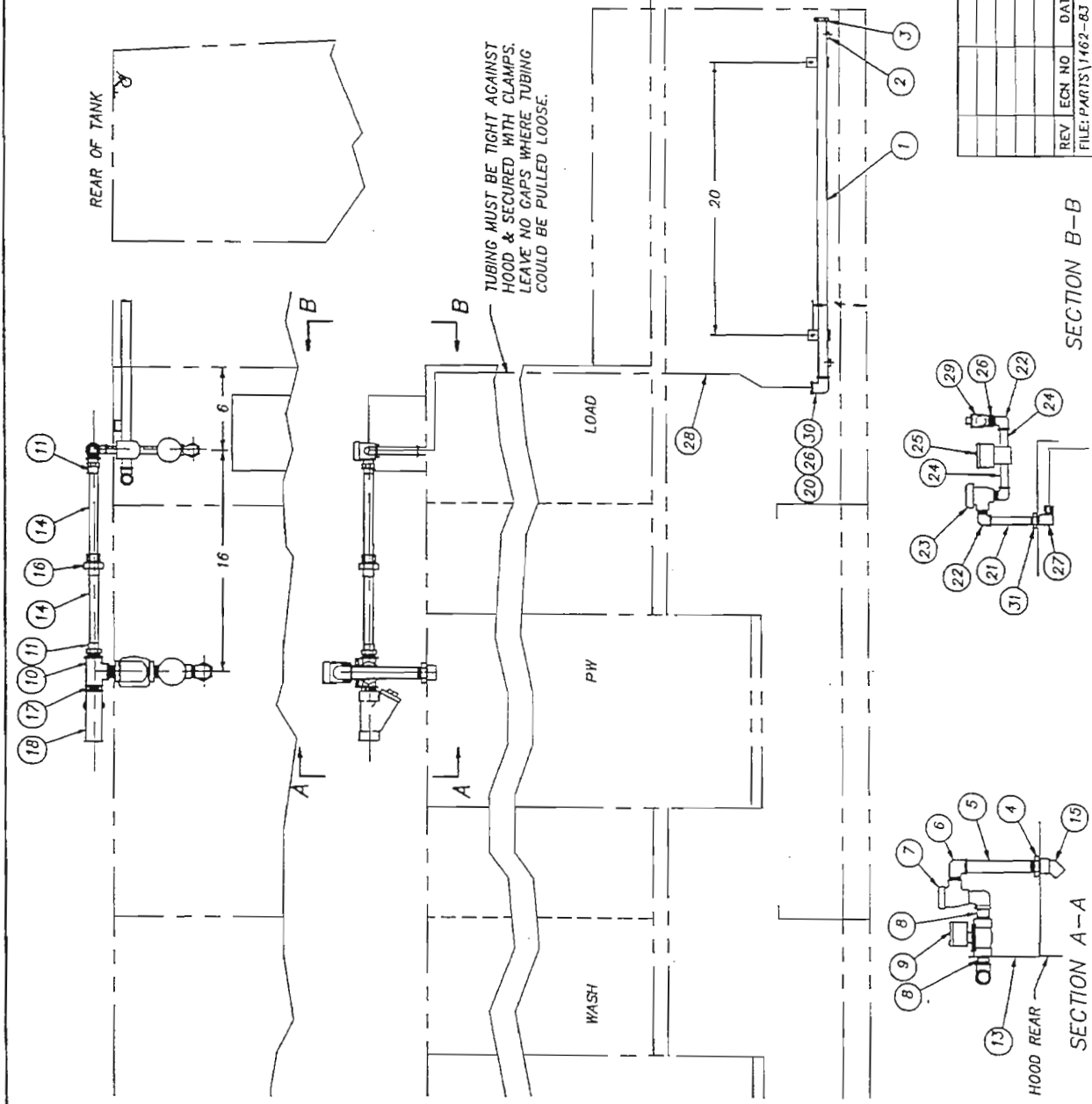

R.H. SHOWN L.H. OPPOSITE

REAR OF TANK

LOAD

WASH

HOOD REAR

SECTION A-A

SECTION B-B

TOLERANCES ±1/64
FRACTIONS ±.005
DECIMALS .XXX ±.01
.XX ±.01
ANGLES ±1/2°
UNLESS OTHERWISE SPECIFIED

REV ECN NO DATE
FILE: PARTS\1462-BJ

TITLE COLD WATER THERMOSTAT/
LOAD FLUSH PIPING

MATL NOTED

SCALE 1-8

USED ON DEFENDER

ORWN/DATE CES

1462-83

REQD BY HOTEL

NEXT ASSY DWG. NO.

INSINGER
Machine Company

Philadelphia, PA 19135
(215) 624-4800
FAX (215) 624-0966

1.15.97

ITEM	PART NO.	SIZE	DESCRIPTION	QTY.
1	1100-289	B	CONVEYOR OVERLOAD SHUTOFF	1
2	1100-117	B	DRIVE SHAFT ASSY	1
3	-	-	MOTOR BALDOR M3108 ODP	1
4	D-2344A	-	REDUCER BOND 262B 64:1	1
5	O-2527	-	PULLEY 7.95 O.D.	1
6	818-16	A	PULLEY	1
7	D2-582	-	"V" BELT 4L450	1
8	1100-123	B	STOP BAR ASSY & LOCATION	1
9	1390-80	A	COVER, MECHANISM GUARD	1
10	D2-843	A	BRACKET, MECHANISM GUARD	2
11	1390-89	A	SHIM	2

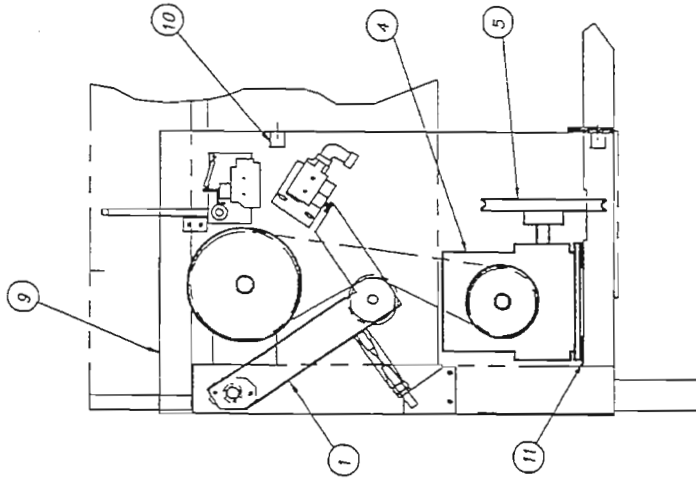
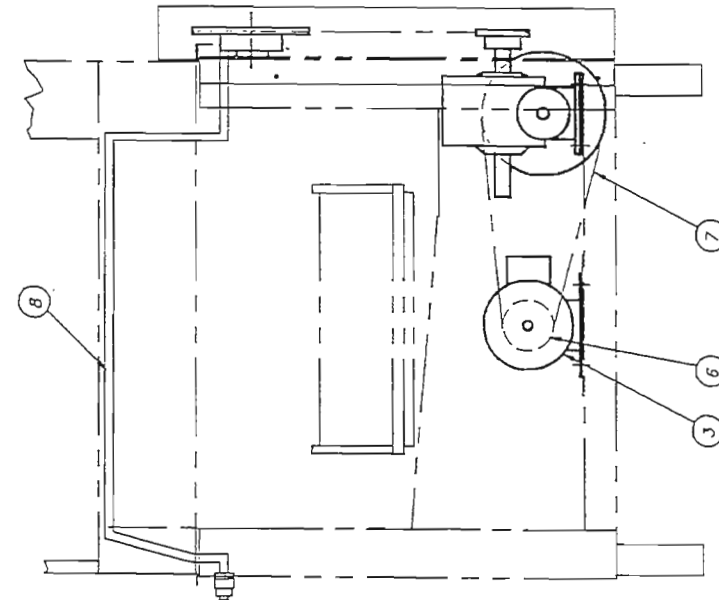
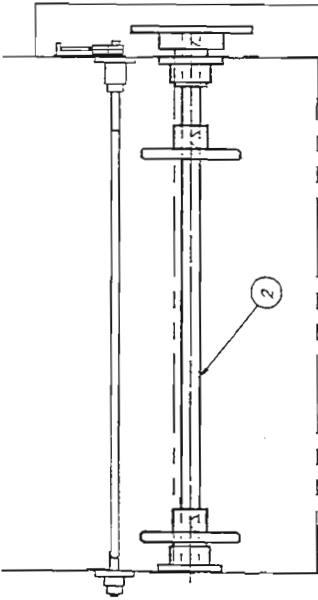

UNLOAD END

R.H. SHOWN L.H. OPPOSITE

TOLERANCES	TITLE	NEXT ASSY DWG. NO.
FRACTIONS ±1/64	CONVEYOR DRIVE ASSEMBLY	1390-72
DECIMALS .005	AS NOTED	1390-72
XXX ± .01		
XX ± .01		
ANGLES ±1/2°		
UNLESS OTHERWISE SPECIFIED		
REV	ECN NO	DATE
FILE: PARTS	1390-72	
 Insinger Machine Company Philadelphia, PA 19135 (215) 624-4800 FAX (215) 624-8866		
SCALE	1"=8"	USED ON CENTURY
REV'D	1	PC
DRWN/DATE		4.15.93

ITEM	PART NO.	DESCRIPTION	QTY.
1	1100-285	ADJUSTABLE SPRING STOP	1
2	1100-309	SHIM	1
3	D312C-LC-2	1/2-13 HEX NUT	1
4	D312C-LC-1	1/2-13 JAM NUT	1
5	1100-286	ATC PIVOT CUP	1
6	D2-525	1/8 THK SPACER	3
7	D470A	1/16 THK WASHER	1
8	1100-287	ATC ARM WELDMENT	1
9	1100-288	MICROSWITCH BRACKET	1
10	D351	SPRING	1
11	D2215A	MICROSWITCH	1
12	1100-310	IDLER SPROCKET	1
13	D2714	60B18 F 1" SPROCKET	1
14	D2760	60B13-F 1" SPROCKET	1
15	D308C-60	ROLLER CHAIN, 48 3/4 LG	1
16	D308C-60	ROLLER CHAIN, TBD LG	1
17	D308C-60	ROLLER CHAIN, 49" LG.	1
18	D308C-60CL	ROLLER CHAIN CONN. LINK	1
19	D311-22	S/S COTTER PIN, 1/8 x 1 1/4	2
20	D309C-GC-5	1/4-20 x 5/8 LG WELD STUD	2
21	D2-146A	60B29 1 1/8 SPROCKET	1
22	D-2333	60B36-F 1 1/8 SPROCKET	1
23	D2388A	60B26F 1 1/8 SPROCKET	1
24	D2761	60B30-F 1 1/8 SPROCKET	1
25	1100-311	ADJUSTABLE SPRING STOP	1
26	1100-312	SHIM	1
27	D302-2	#15 WOODRUFF KEY (1/4 X 1)	1
28	-	-	-
29	-	-	-

RIGHT HAND SHOWN LEFT HAND OPPOSITE
DRAWN TO SCALE FOR MASTER MACHINE

TOLERANCES	2.25.97	1515	2.25.97	REV	ECN NO	DATE
FRACTIONS ±1/64	12.20.96	D 1511	12.20.96	1515	1100-289	
DECIMALS .XXX ±.005	8.26.93	C 929	8.26.93	929		
.XX ±.01	J.12.93	B 851	J.12.93	851		
ANGLES ±1/2°	-	A 560	-	560		
UNLESS OTHERWISE SPECIFIED						

TITLE	CONVEYOR OVERLOAD SHUTOFF ASSEMBLY	REQD	1100-289
MATL		SCALE	1=4
		USED ON	CLIP/MASTER
		DRWN/DATE	JRS 4.15.91

Insigner
Machine Company
Philadelphia, PA 19135
(215) 824-4800
FAX (215) 624-6906

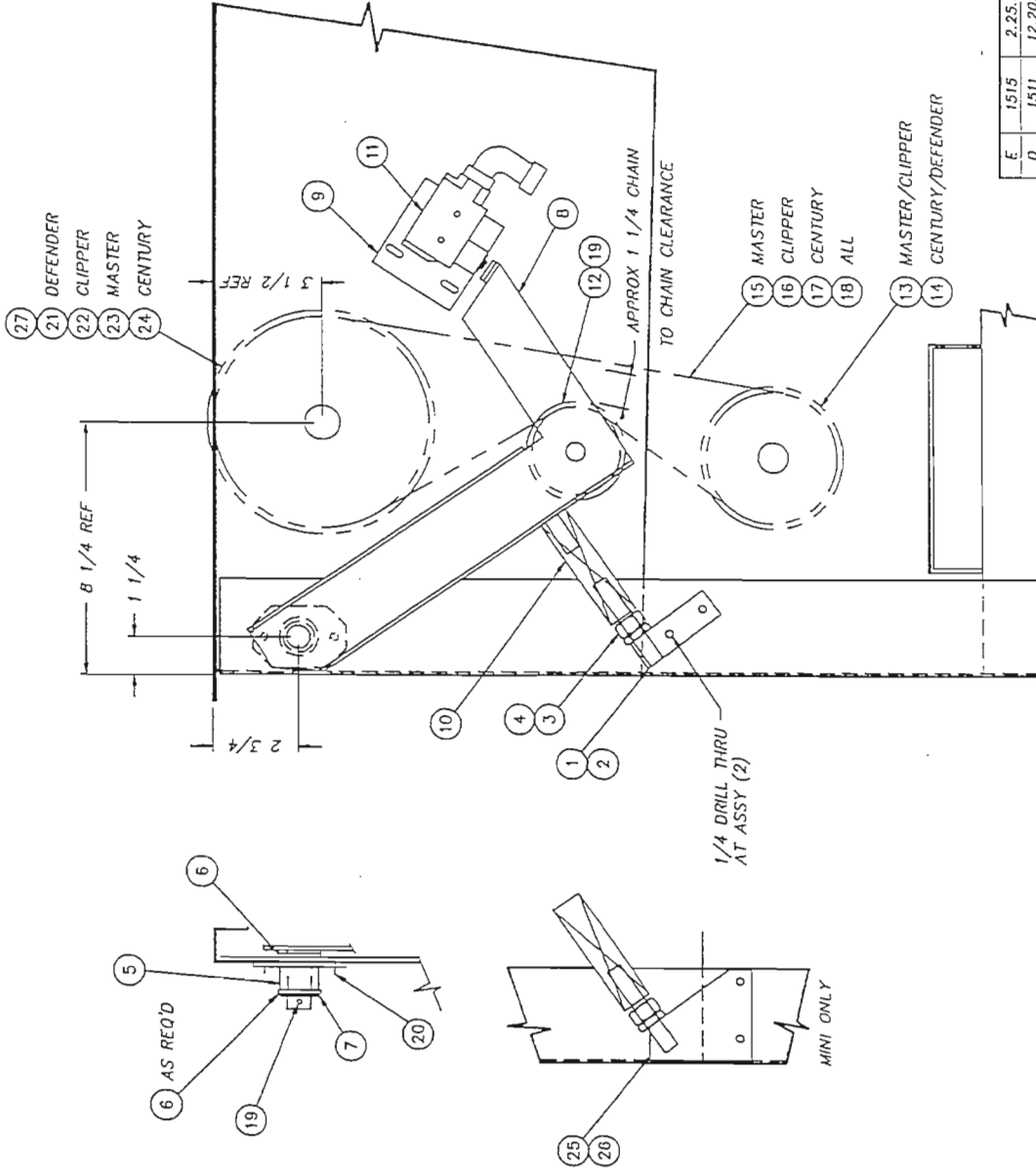

ITEM	PART NO.	SIZE	DESCRIPTION	QTY.
1	1100-118	A	DRIVE SHAFT	1
2	D2-138	B	BELT SPROCKET, DRIVEN	2
3	1100-119	A	BRACKET, DRIVE SHAFT BRG	2
4	1100-120	A	BUSHING	2
5	1100-339	A	SPACER, 1/8 THK	1
6	D311-17	-	COTTER PIN, 1/8 DIA x 2	1
7	1100-122	A	SPACER, 5/16 THK	2
8	-	-	-	-
9	D302-2	-	#15 WOODRUFF KEY (1/4 x 1)	2

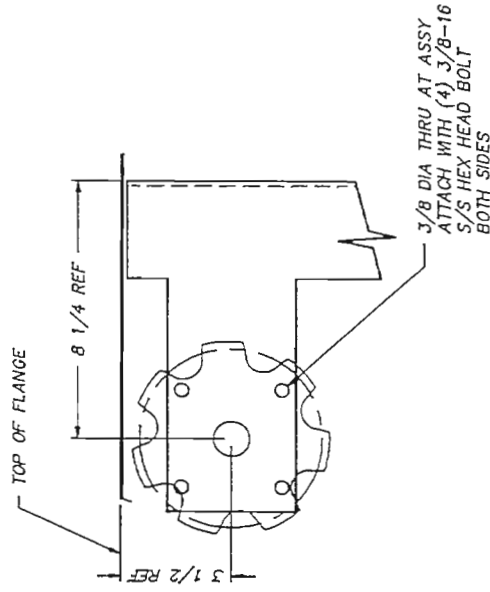
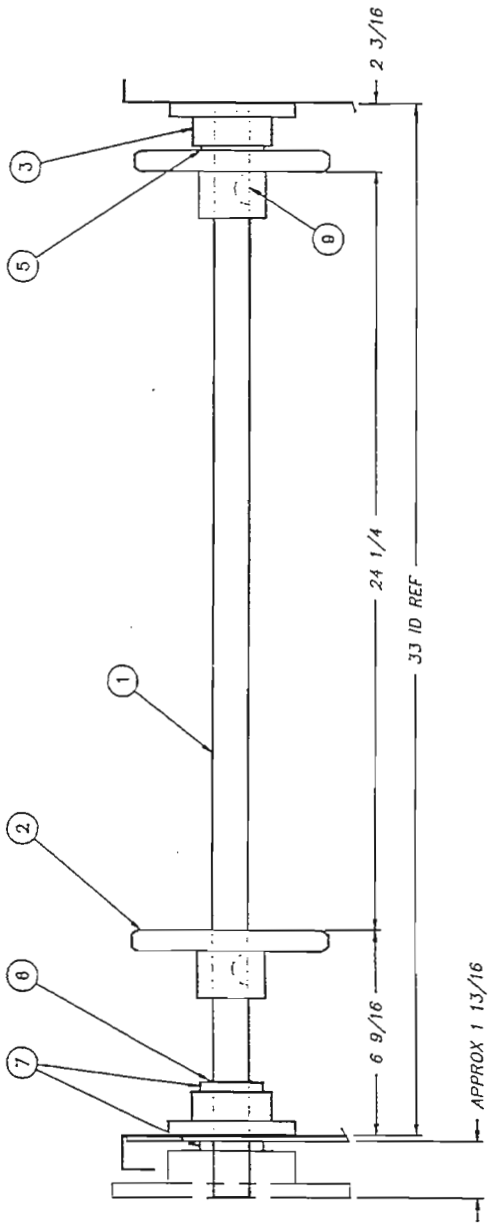

TOLERANCES		TITLE		NEXT ASSY DWG. NO.	
FRACTIONS	DECIMALS	DRIVE SHAFT ASSEMBLY	REC'D	1100-117	USED ON
±1/64	±.005	MATL	SCALE	1/4	DRWN/DATE
.XXX ±.005	.XX ±.01	NOTED			MFU
.XX ±.01	ANGLES ±1/2°	 Philadelphia, PA 19135 (215) 824-4800 FAX (215) 824-8800			
UNLESS OTHERWISE SPECIFIED	FILE: PARTS\1100-117	J.25.BJ 3.25.83			

ITEM	PART NO.	SIZE	DESCRIPTION	QTY.
1	D2-138	A	SPROCKET- BELT	2
2	1100-146	A	SHAFT -- DRIVEN	1
3	D2-B*8	A	COLLAR	4
4	1390-50	A	CHANNEL	2
5	D312C-CC-2	-	HEX NUT S/S 1/4-20	4
6	1390-51	A	ADJUSTING SCREW	2
7	D2-039	A	COLLAR	2
8	D-585	-	"O" RING (O1-014)	2
9	D312C-LC-2	-	HEX NUT S/S 1/2-13	2
10	1462-38	B	LEGS	REF

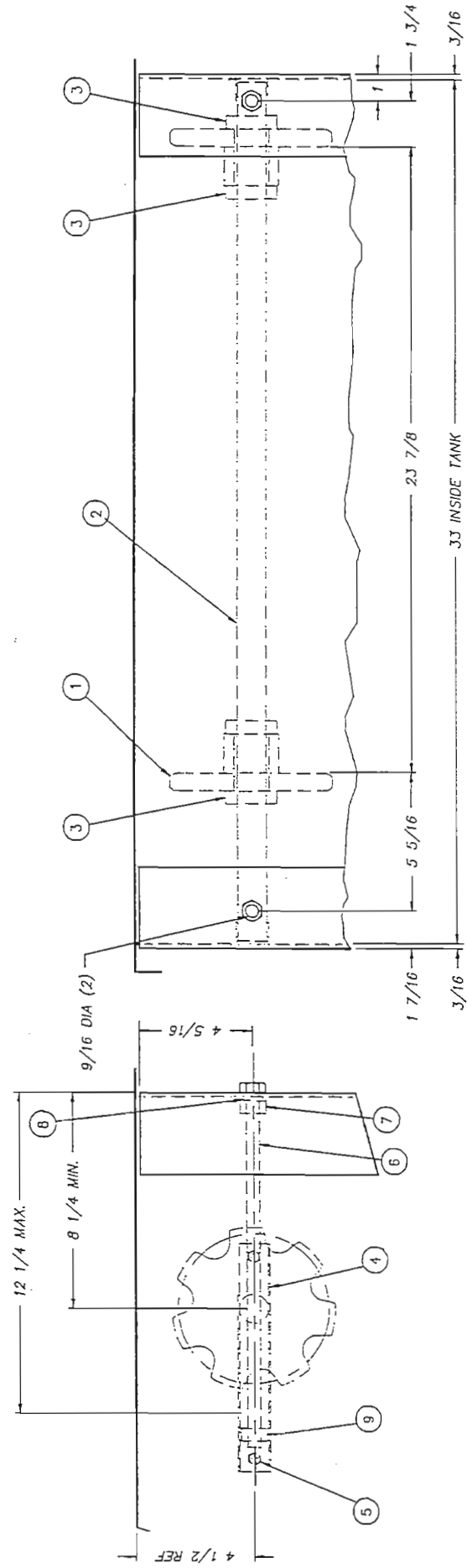

NOTE: STD MASTER CLIPPER LEGS (#1100-46) EXCEPT HEIGHT OF 9/16 DIA HOLES

R.H. SHOWN - L.H. OPPOSITE

TOLERANCES	FRACCTIONS ±1/64	DECIMALS	XX ± .005	XX ± .01	ANGLES ±1/2°	UNLESS OTHERWISE SPECIFIED												
REV	ECN NO	DATE	FILE: P407S\1462-21															
<table border="0"> <tr> <td>TITLE</td> <td>DRIVEN SHAFT ASSEMBLY (LOAD END)</td> <td>NEXT ASSY DWG. NO.</td> <td>1462-1</td> </tr> <tr> <td>REQD</td> <td>1</td> <td>SCALE</td> <td>1=4</td> </tr> <tr> <td>MAT'L</td> <td>NOTED</td> <td>USED ON</td> <td>DEFENDER</td> </tr> </table>							TITLE	DRIVEN SHAFT ASSEMBLY (LOAD END)	NEXT ASSY DWG. NO.	1462-1	REQD	1	SCALE	1=4	MAT'L	NOTED	USED ON	DEFENDER
TITLE	DRIVEN SHAFT ASSEMBLY (LOAD END)	NEXT ASSY DWG. NO.	1462-1															
REQD	1	SCALE	1=4															
MAT'L	NOTED	USED ON	DEFENDER															
<table border="0"> <tr> <td colspan="2"> </td> <td colspan="2"> Philadelphia, PA 19135 (215) 824-4800 FAX (215) 824-8868 </td> </tr> <tr> <td colspan="2">Machine Company</td> <td colspan="2">CES</td> </tr> </table>									Philadelphia, PA 19135 (215) 824-4800 FAX (215) 824-8868		Machine Company		CES					
		Philadelphia, PA 19135 (215) 824-4800 FAX (215) 824-8868																
Machine Company		CES																
<table border="0"> <tr> <td>ORWN/DATE</td> <td>7.11.96</td> </tr> </table>							ORWN/DATE	7.11.96										
ORWN/DATE	7.11.96																	

ITEM	DESCRIPTION	PART NO.	QTY.
1	STOP BAR	DWG. 1100-126	1
2	BEARING - FRONT	DWG. D2-141	1
3	BEARING - REAR	DWG. 1100-124	1
4	COLLAR	DWG. D2-839	2
5	BRACKET - STOP	DWG. 1100-125	1
6	BRACKET - MICROSWITCH MTC.	DWG. 1100-130	1
7	ACTUATOR - MICROSWITCH	DWG. 1100-131	1
8	SPRING	DWG. 1100-132	1
9	MICROSWITCH B2E6-2RN	D-2215A	1

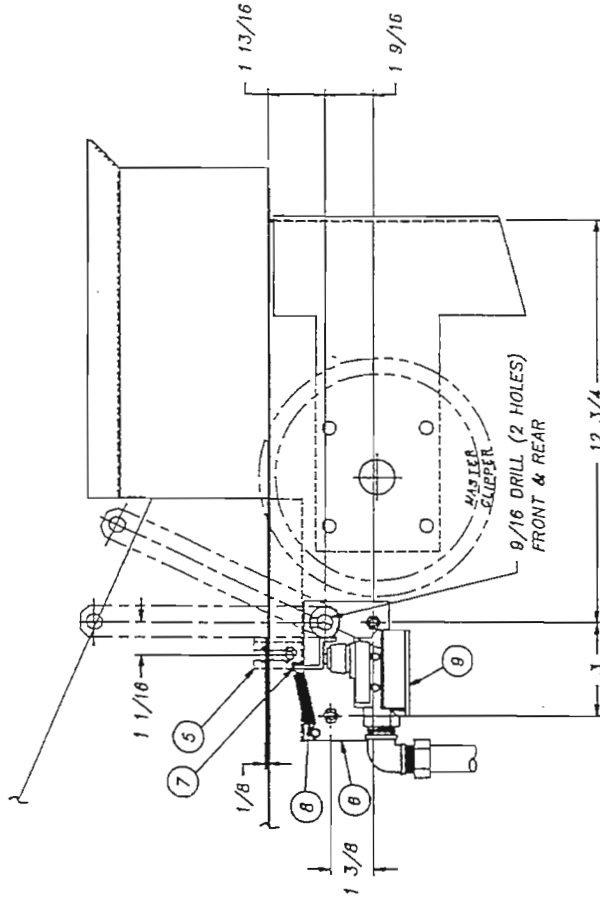
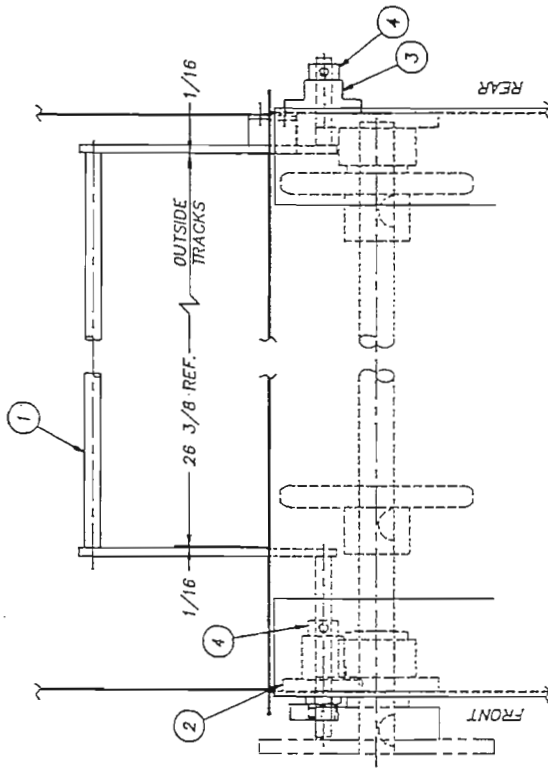

L.H. SHOWN - R.H. OPPOSITE

TOLERANCES		TITLE		NEXT ASSY DWG. NO.	
FRACTIONS	±1/64	STOP BAR ASS'Y	REV'D	1	1100-123
DECIMALS	.XXX ± .005	& LOCATION	SCALE	1:4	USED ON
ANGLES	± 1/2°	MAT'L			RC-21 W
UNLESSE	OTHERWISE SPECIFIED				DRWN/DATE
REV	ECN NO	DATE	 Insinger Philadelphia, PA 19133 (215) 824-4800 FAX (215) 824-8888		
FILE: PARTS	1100-123				12.5.83

ITEM	PART NO.	SIZE	DESCRIPTION	QTY.	ITEM	PART NO.	SIZE	DESCRIPTION	QTY.	ITEM	PART NO.	SIZE	DESCRIPTION	QTY.
1	964-50	B	DRAIN ASSEMBLY	2	11	D-514	A	GASKET	2	21	D-135	A	FLANGE, LOAD (PATTERN P8-2)	1
2	D207A-B12-11	-	COPPER TUBING 1 1/2 CTS X 2 3/4 LG	1	12	D-108	A	STRAINER	2	22	D316A-U3-43	-	TEE DRAINAGE 2C X 1 1/2C X 1 1/2C	1
3	D207A-B12-16	-	COPPER TUBING 1 1/2 CTS X 4 LG	1	13	D207A-B12-20	-	COPPER TUBING 2 CTS X 4 7/8 LG	1	23	D346A-U3-U3	-	TEE DRAINAGE 2C	1
4	D207A-B12-8	-	COPPER TUBING 1 1/2 CTS X 2 LG	1	14	D316A-U3-U3	-	90° ELBOW 2" C	1	24	D317A-N-4	-	ADAPTER 2 PPS X 2 FTB	1
5	D316A-N3-113	-	90° ELL 1 1/2 C	3	15	D207A-B12-45	-	COPPER TUBING 2 CTS X 11 1/4 LG	1	25	1103-37	A	BRACKET, PIPING SUPPORT	2
6	D207A-B12-48	-	COPPER TUBING 1 1/2 CTS X 12	2	16	D-80	A	CLASP, STRAINER	2	26	D316A-N3-113	-	UNION 1 1/2 C	1
7	D346A-U3-U3	-	TEE DRAINAGE 2 C X 2 C X 1 1/2 C	1	17	D207A-B12-36	-	COPPER TUBING 1 1/2 CTS X 9 LG	1	27	-	-	-	-
8	D207A-B12-104	-	COPPER TUBING 2 CTS X 48 LG	1	18	D207A-B12-22	-	COPPER TUBING 1 1/2 CTS X 5 1/2 LG	1	28	-	-	-	-
9	D207A-B12-24	-	COPPER TUBING 2 CTS X 6 LG	1	19	0332A-N3-113	-	90° ELBOW 1 1/2 C	1	-	-	-	-	-
10	D-134	A	FLANGE, UNLOAD	1	20	D207A-B12-148	-	COPPER TUBING 1 1/2 CTS X 37 LG	1	-	-	-	-	-

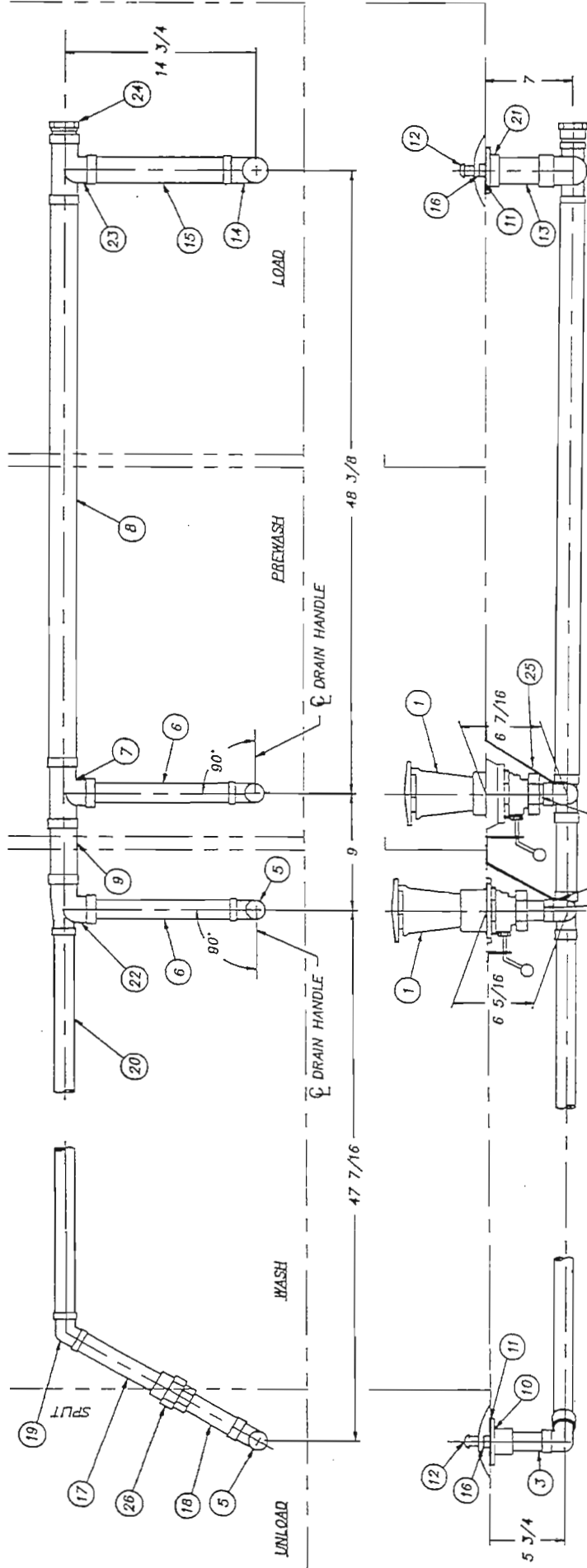

TOLERANCES	TITLE	FRACCTIONS ±1/84	DECIMALS ±.005	ANGLES ±1/2°	UNLESS OTHERWISE SPECIFIED
REV	ECN NO	DATE	FILE: PARTS\1462-70	REV'D	NOTED
1				1/8	1/8
2				1/8	1/8
3				1/8	1/8
4				1/8	1/8
5				1/8	1/8
6				1/8	1/8
7				1/8	1/8
8				1/8	1/8
9				1/8	1/8
10				1/8	1/8
11				1/8	1/8
12				1/8	1/8
13				1/8	1/8
14				1/8	1/8
15				1/8	1/8
16				1/8	1/8
17				1/8	1/8
18				1/8	1/8
19				1/8	1/8
20				1/8	1/8
21				1/8	1/8
22				1/8	1/8
23				1/8	1/8
24				1/8	1/8
25				1/8	1/8
26				1/8	1/8
27				1/8	1/8
28				1/8	1/8
29				1/8	1/8
30				1/8	1/8
31				1/8	1/8
32				1/8	1/8
33				1/8	1/8
34				1/8	1/8
35				1/8	1/8
36				1/8	1/8
37				1/8	1/8
38				1/8	1/8
39				1/8	1/8
40				1/8	1/8
41				1/8	1/8
42				1/8	1/8
43				1/8	1/8
44				1/8	1/8
45				1/8	1/8
46				1/8	1/8
47				1/8	1/8
48				1/8	1/8
49				1/8	1/8
50				1/8	1/8
51				1/8	1/8
52				1/8	1/8
53				1/8	1/8
54				1/8	1/8
55				1/8	1/8
56				1/8	1/8
57				1/8	1/8
58				1/8	1/8
59				1/8	1/8
60				1/8	1/8
61				1/8	1/8
62				1/8	1/8
63				1/8	1/8
64				1/8	1/8
65				1/8	1/8
66				1/8	1/8
67				1/8	1/8
68				1/8	1/8
69				1/8	1/8
70				1/8	1/8
71				1/8	1/8
72				1/8	1/8
73				1/8	1/8
74				1/8	1/8
75				1/8	1/8
76				1/8	1/8
77				1/8	1/8
78				1/8	1/8
79				1/8	1/8
80				1/8	1/8
81				1/8	1/8
82				1/8	1/8
83				1/8	1/8
84				1/8	1/8
85				1/8	1/8
86				1/8	1/8
87				1/8	1/8
88				1/8	1/8
89				1/8	1/8
90				1/8	1/8
91				1/8	1/8
92				1/8	1/8
93				1/8	1/8
94				1/8	1/8
95				1/8	1/8
96				1/8	1/8
97				1/8	1/8
98				1/8	1/8
99				1/8	1/8
100				1/8	1/8

NOTE: USE 1/8" POP RIVET & SEALANT TO FASTEN SUPPORT TO DRAINAGE ELBOW.

R.H. MACHINE ONLY

Insinger
 Machine Company
 Philadelphia, PA 19135
 (215) 624-4800
 FAX (215) 624-8886

TITLE	DRAIN ASSEMBLY	SCALE	1/8
DATE	NOTED	USED ON	DEFENDER 17
REV	NOTED	DRWN/DATE	CES
FILE: PARTS\1462-70		REV'D	1462-70R
		SCALE	1/8
		USED ON	DEFENDER 17
		DRWN/DATE	CES
		FAX (215) 624-8886	8.0.96

ITEM	PART NO.	SIZE	DESCRIPTION	QTY.	ITEM	PART NO.	SIZE	DESCRIPTION	QTY.	ITEM	PART NO.	SIZE	DESCRIPTION	QTY.
1	D207A-B12-11	B	DRAIN ASSEMBLY	2	11	D-314	A	WASHER	2	21	D-135	A	FLANGE LOAD (PATTERN P6-2)	1
2	D207A-B12-11	-	COPPER TUBING 1 1/2 CTS X 2 3/4 LG	1	12	D-108	A	STRAINER	2	22	D348A-UN3HJ	-	TEE DRAINAGE 2C X 1 1/2C X 1 1/2C	1
3	D207A-B12-16	-	COPPER TUBING 1 1/2 CTS X 4 LG	2	13	D207A-B16-20	-	COPPER TUBING 2 CTS X 4 7/8 LG	1	23	D348A-UN3HJ	-	TEE DRAINAGE 2C	1
4	D207A-B12-9	-	COPPER TUBING 1 1/2 CTS X 2 1/4 LG	1	14	D318A-J3-J3	-	90° ELBOW 2 C	1	24	D317A-J1-J4	-	ADAPTER 2 PPS X 2 FTD	1
5	D318A-HJ-H3	-	90° ELL 1 1/2 C	1	15	D207A-B16-45	-	COPPER TUBING 2 CTS X 11 1/4 LG	1	25	1103-37	A	BRACKET, PIPING SUPPORT	2
6	D207A-B12-46	-	COPPER TUBING 1 1/2 CTS X 12	1	16	D-90	A	CLASP STRAINER	1	26	D318A-H3-H3	-	UNION 1 1/2 C	1
7	D348A-UN3HJ	-	TEE DRAINAGE 2 C X 2 C X 1 1/2 C	1	17	-	-	-	1	27	D348A-UN3HJ	-	TEE, DRAIN 1 1/2C X 1 1/2C X 1 1/2C	1
8	D207A-B16-100	-	COPPER TUBING 2 CTS X 23 LG	1	18	-	-	-	1	28	D328F-H2A	-	PIPE PLUG 1 1/2 IPS	1
9	D207A-B16-170	-	COPPER TUBING 2 CTS X 43 1/2 LG	1	19	D332A-H3-H3	-	90° ELBOW 1 1/2 C	1					
10	D-134	A	FLANGE, UNLOAD	1	20	D207A-B12-116	-	COPPER TUBING 1 1/2 CTS X 20 LG	1					

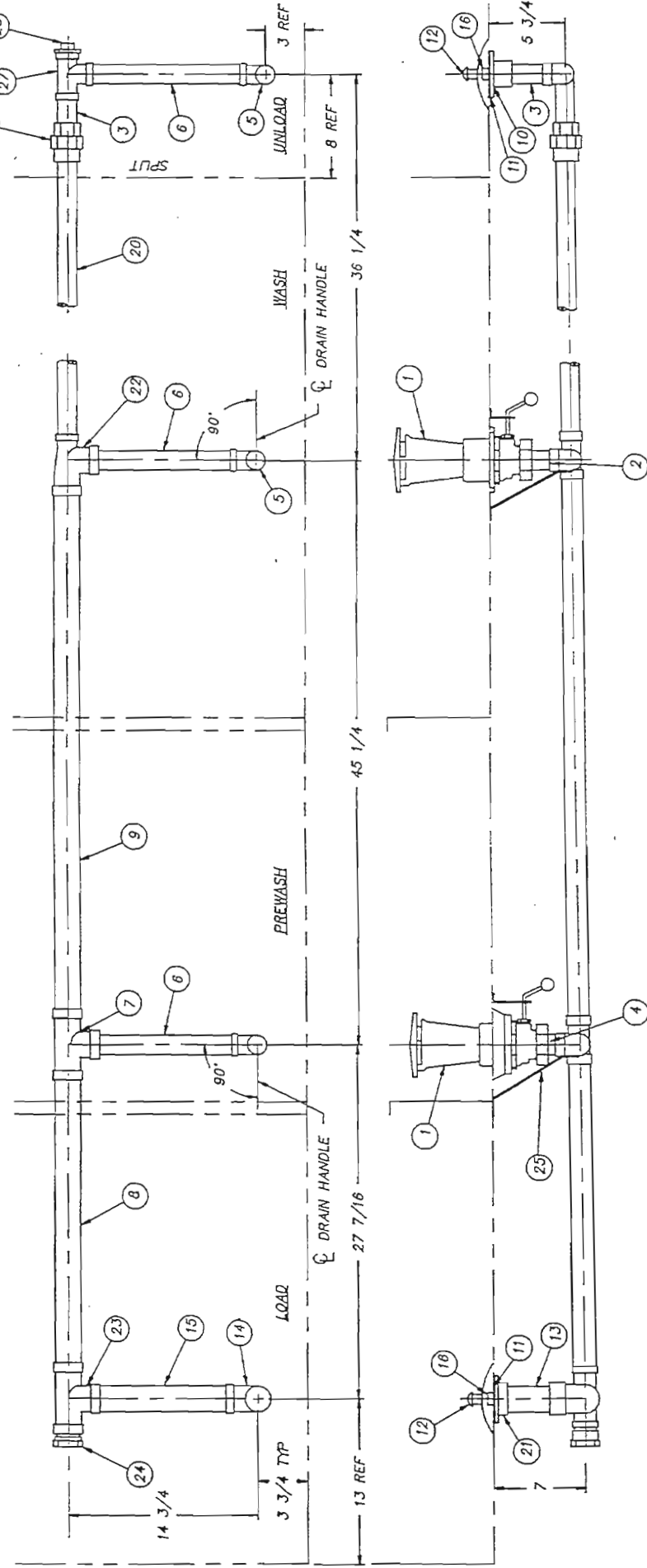

TOLERANCES	FRACTIONS ±1/64	DECIMALS	XXX ± .005	YY ± .01	ANGLES ±1/2°	UNLESS OTHERWISE SPECIFIED																				
REV	ECN NO	DATE	FILE: PARTS 1462-70																							
<table border="0"> <tr> <td>TITLE</td> <td>DRAIN ASSEMBLY</td> <td>REQ'D</td> <td>1462-70L</td> </tr> <tr> <td>MAT'L</td> <td>SINGLE CONNECTION</td> <td>NOTED</td> <td>USED ON</td> </tr> <tr> <td></td> <td>NOTED</td> <td>SCALE</td> <td>1/8</td> </tr> <tr> <td></td> <td></td> <td>DEFENDER</td> <td>17</td> </tr> <tr> <td></td> <td></td> <td>DRWN/DATE</td> <td>CES</td> </tr> </table>							TITLE	DRAIN ASSEMBLY	REQ'D	1462-70L	MAT'L	SINGLE CONNECTION	NOTED	USED ON		NOTED	SCALE	1/8			DEFENDER	17			DRWN/DATE	CES
TITLE	DRAIN ASSEMBLY	REQ'D	1462-70L																							
MAT'L	SINGLE CONNECTION	NOTED	USED ON																							
	NOTED	SCALE	1/8																							
		DEFENDER	17																							
		DRWN/DATE	CES																							
<table border="0"> <tr> <td>NEXT ASSY/DWG. NO.</td> <td>1462-70L</td> </tr> <tr> <td>INSINGER</td> <td>Philadelphia, PA 19135</td> </tr> <tr> <td>Machine Company</td> <td>(215) 624-4800</td> </tr> <tr> <td></td> <td>FAX (215) 624-8068</td> </tr> </table>							NEXT ASSY/DWG. NO.	1462-70L	INSINGER	Philadelphia, PA 19135	Machine Company	(215) 624-4800		FAX (215) 624-8068												
NEXT ASSY/DWG. NO.	1462-70L																									
INSINGER	Philadelphia, PA 19135																									
Machine Company	(215) 624-4800																									
	FAX (215) 624-8068																									

L.H. MACHINE ONLY

ITEM	PART NO.	DESCRIPTION	QTY.
1	954-50A	UPPER BODY	1
2	954-50B	LOWER BODY	1
3	954-50C	NUT	1
4	954-50D	OVERFLOW TUBE	1
5	1370-3	SKIMMER CAP (MODIFIED)	1
6	D2-557	"V" SEAL	1
7	D2-548	O RING	1
8	D2-549	O RING	1
9	D2-550	O RING	2
10	1370-5	SKIMMER CAP TAB	1
11	1370-11	PLUG	1
12	D316A-H3-H1	90° ELL 1-1/2 C x 1-1/2 FPT	1
13	1370-6	UPPER BRACKET	1
14	1370-7	LOWER BRACKET	1
15	D-207A-B12-17	CU TUBE, 1-1/2 CTS x 4-1/4 LG	1
16	D2738	SPRING PLUNGER	1
17	1370-30	LIFT HANDLE	1
18	D311-8	ROLL PIN, 1/8 DIA	2
19	SEE TABLE	LIFT ROD	1
20	D2739	CLAMP COLLAR, 1/4 DIA	1
21	SK 3476	DECAL	1
22	1370-51	INSTALLATION NOTES	X
23	D305	DRAIN LOCKING NUT	1

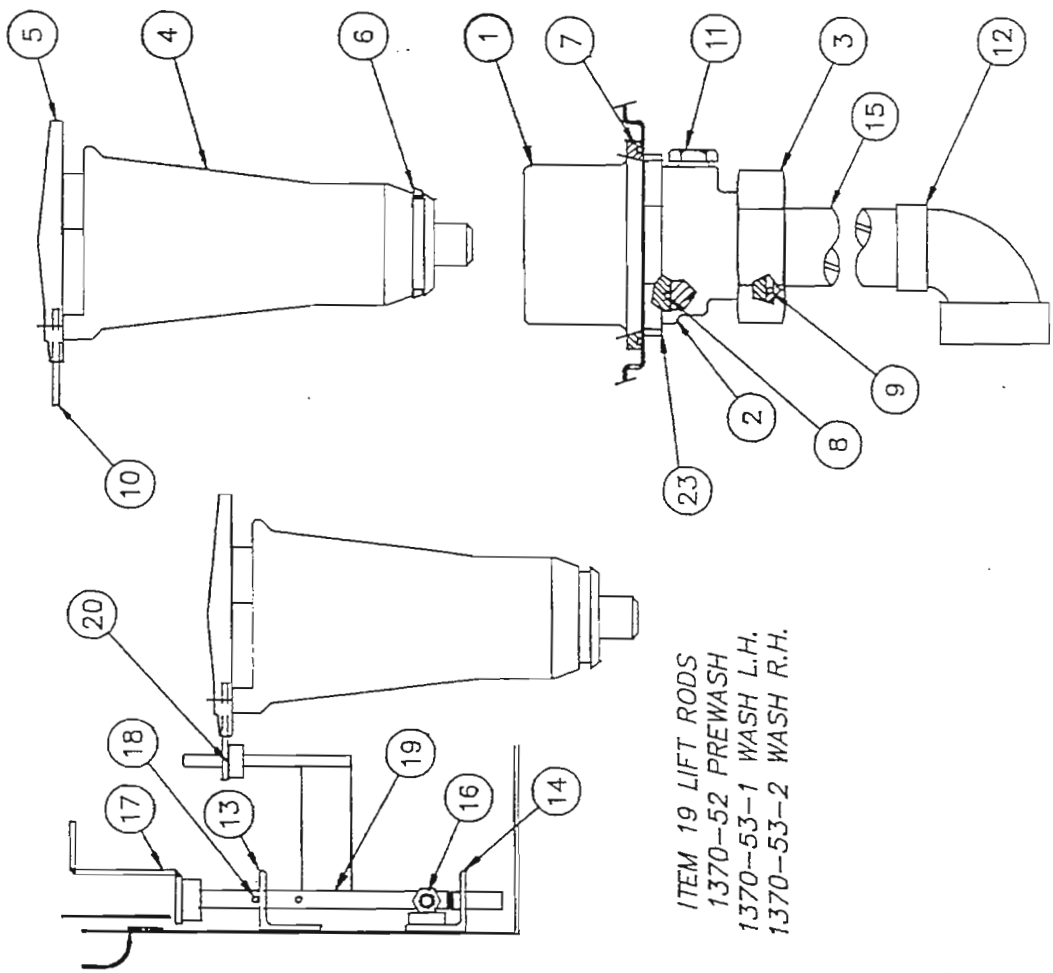

ITEM 19 LIFT RODS
 1370-52 PREWASH
 1370-53-1 WASH L.H.
 1370-53-2 WASH R.H.

TOLERANCES	
FRACTIONS ±1/64	
DECIMALS	
.XXX ± .005	
.XX ± .01	
ANGLES ±1/2°	
UNLESS OTHERWISE SPECIFIED	
REV	ECN NO DATE
	FILE: PARTS\1370-54

TITLE	DRAIN ASSY - SELF CLOSING DEFENDER STEAM HEAT	NEXT ASSY	DWG. NO.
MATL	NOTED	REQD	2
		SCALE	1=4
			USED ON DEFENDER
Insinger Machine Company Philadelphia, PA 19135 (215) 624-4800 FAX (215) 624-6966		DRWN/DATE	CES 1.3.97

ITEM	PART NO.	SIZE	DESCRIPTION	QTY.	ITEM	PART NO.	SIZE	DESCRIPTION	QTY.
1	D317A-L3-L2	-	ADAPTER 3 MIPS X 3 C	1	8	D313A-1J	-	COPPER WASHER 3/8	4
2	D316A-L3-L4	-	90° STREET ELBOW 3 CTS X 3 CFTG	1	9	D312C-JC-5	-	LOCKNUT 3/8-16	4
3	D207A-K24	-	COPPER TUBING 3 CTS X 3 1/4 LG	1	10	D2-541	A	STRAINER	1
4	D-530	A	GASKET	1	11	D3-825	A	CLASP	1
5	1104-68	A	FLANGE, TANK	1	12	D312C-EF-8	-	ALL-METAL LOCKNUT #10-32 S/S	1
6	D2-135	A	FLANGE, STRAINER	1					
7	D309C-JC-12	-	HEX HD SCR 3/8-16 X 1 1/2 LG	4					

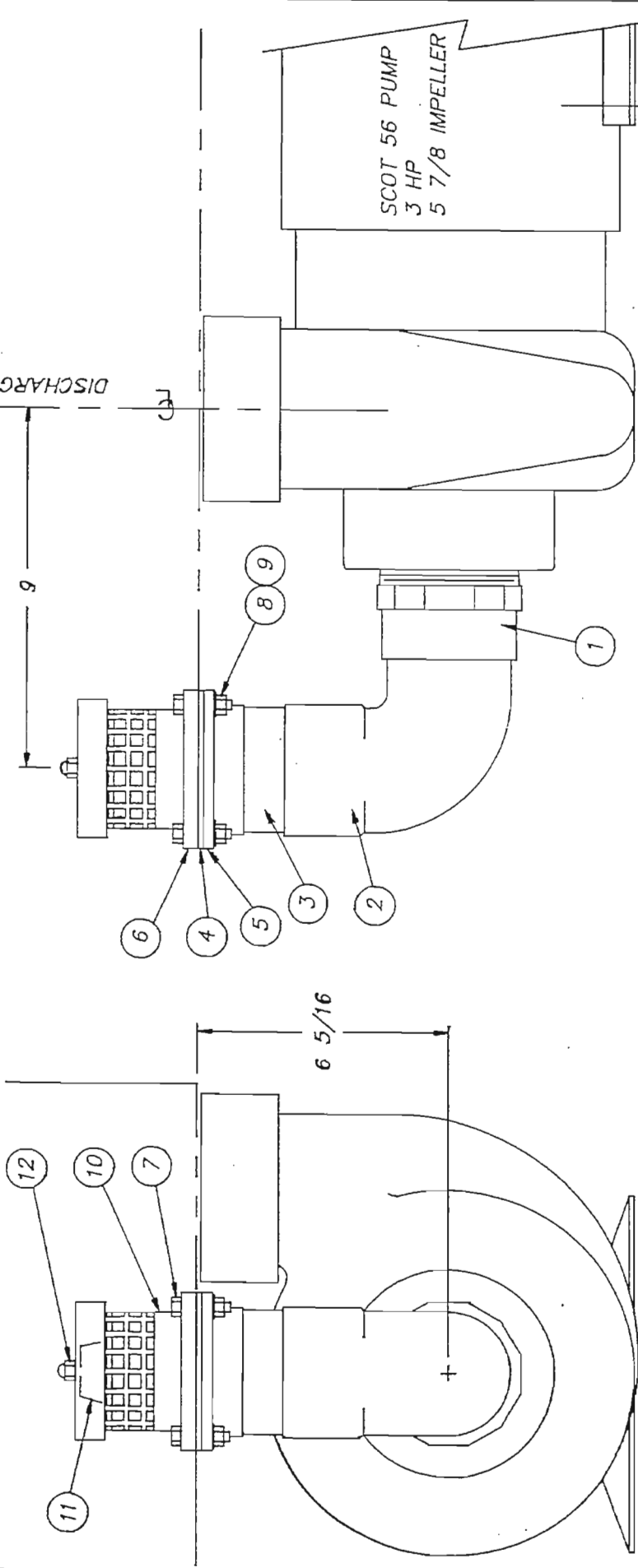

TOLERANCES		TITLE	SUCTION LINE ASSY	NEXT ASSY DWG. NO.
FRACTIONS ±1/64	DECIMALS			
.XXX ± .005	.XX ± .01	MAT'L	SCALE	USED ON
ANGLES ±1/2°	UNLESS OTHERWISE SPECIFIED		1/4	DEFENDER 17
REV	ECN NO	DATE	DRWN/DATE	
			CES	
FILE: PARTS \1462-69		Philadelphia, PA 19135		9.6.96
		(215) 624-4800		
		FAX (215) 624-6966		

NOTE: SAME AS #1104-69

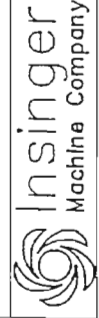

InSinger
Machine Company

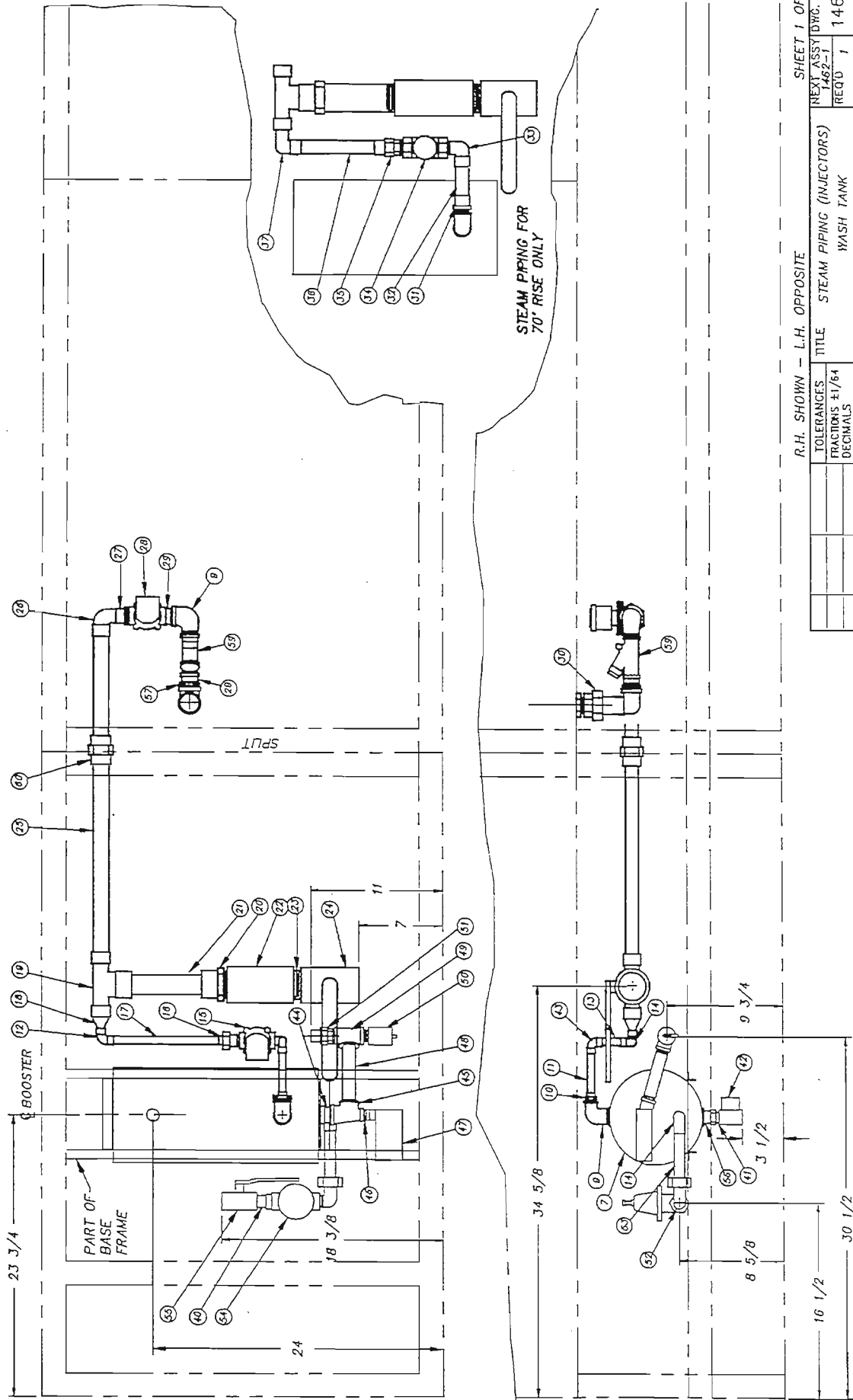

R.H. SHOWN - L.H. OPPOSITE		SHEET 1 OF 2	
TOLERANCES	FRACTIONS ±1/64	NEXT ASSY DWG. NO.	1462-1
	DECIMALS .XXX ± .005	REQD	1
	.XX ± .01	SCALE	1=B DEFENDER
	ANGLES ±1/2°	USED ON	DRWR/DATE
	UNLESS OTHERWISE SPECIFIED	PHILADELPHIA, PA 19135	CES
REV	ECN NO	DATE	FILE: PARTS\1462-72
			Machine Company Philadelphia, PA 19135 (215) 624-4800 FAX (215) 624-8000
			INSINGER
			AS NOTED
			WASH TANK
			STEAM PIPING (INJECTORS)
			1462-72

ITEM	PART NO.	DESCRIPTION	QTY.	ITEM	PART NO.	DESCRIPTION	QTY.
31	D317A-F3-F2	ADAPTER 1" C X 1" MIPS	1	1			
32	D207A-B6-16	COPPER TUBING 1" IPS X 4	1	2	D-2456	STEAM INJECTOR - 1 1/4 IPS	1
33	D316A-F3-F2	90° ELBOW 1" C X 1" MIPS	1	3	D326F-C	LOCKNUT 1 1/4 IPS	1
34		SAME AS ITEM #28	1	4			
35	D318A-F3-F2	UNION 1" C X 1" MIPS	1	5	D314F-GA-16	NIPPLE 1 1/4 IPS X 2 ALL THD	1
36	D207A-B6-31	COPPER TUBING 1" CTS X 7 3/4	1	6			
37	D316A-F4-F3	90° ELBOW 1" FTG X 1" C	1	7	D 2100	STEAM BOOSTER (1-2) (SEE NOTE #1)	1
38	D323A-G4-F3	FLUSH BUSH 1 1/4 FTG X 1" C	1	8			
39				9	D316F-F2-F1	90° STREET ELL 1" MIPS X 1" FIPS	2
40	D314F-EC-00	NIPPLE CLOSE 3/4 IPS	1	10	D317A-E3-F2	ADAPTER 3/4 C X 1" MIPS	1
41	D314F-DC-00	NIPPLE CLOSE 1/2 IPS	1	11	D207A-B6-17	COPPER TUBING 3/4 CTS X 4 1/4	1
42	D2102A	STEAM TRAP 1/2 IPS	1	12	D316A-E4-E3	90° STREET ELL 3/4 FTG X 3/4 C	1
43	D316A-E3-E3	90° ELBOW 3/4 C	1	13	D207A-B6-10	COPPER TUBING 3/4 CTS X 2 1/2	1
44	D314F-FC-00	NIPPLE CLOSE 1" IPS	1	14	D316A-E3-E2	90° ELBOW 3/4 C X 3/4 MIPS	2
45	D320F-FID1E1	TEE 1" FIPS X 1/2" FIPS X 3/4 FIPS	1	15	D2595	SOLENOID VALVE 3/4 IPS	1
46	D322F-D2-G1	HEX RED 1/2 MIPS X 3/8 FIPS	1	16	D318F-E3-E2	UNION 3/4 C X 3/4 MIPS	1
47	D2398	THERMOSTAT (SEE NOTE #2)	1	17	D207A-B6-42	COPPER TUBING 3/4 CTS X 10 1/2	1
48	D314A-ES-43	NIPPLE 3/4 IPS X 5 3/8	1	18	D323A-F4-E3	RED. BUSHING 1" FTG X 3/4 C	1
49	D320F-E1E1E1	TEE 3/4 IPS	1	19	D320A-F3F3H3	TEE 1" C X 1" C X 1 1/2" C	1
50	D2507	PRESSURE RELIEF VALVE 3/4 IPS	1	20	D317A-H3H2	ADAPTER 1 1/2 C X 1 1/2 MIPS	1
51	D318A-E3-E2	UNION 3/4 C X 3/4 MIPS	1	21	D201A-B12-36	COPPER TUBING 1 1/2 CTS X 8	1
52	D318A-E3-E2	90° UNION ELL 3/4 C X 3/4 MIPS	1	22	D2848	*Y" STRAINER 1 1/2 IPS	1
53	D207A-B6-24	COPPER TUBING 3/4 CTS X 6	1	23	D314F-HC-00	NIPPLE CLOSE 1 1/2 IPS	1
54	D1012	PRESSURE REG & STRAINER 3/4 IPS	1	24	D2849	BALL VALVE 1 1/2 IPS	1
55	D2340	BALL VALVE 3/4 IPS	1	25	D207A-K8-68	COPPER TUBING 1" CTS X 17	1
56	D322F-E2-D1	HEX RED 3/4 MIPS X 1/2 FIPS	1	26	D316A-F3-F4	90° ELBOW 1" C X 1" CFTG	1
57	D322F-G2-F1	HEX RED 1 1/4 MIPS X 1" FIPS	1	27	D317A-F3-F2	ADAPTER 1" C X 1" MIPS	1
58	D316A-G1-G2	90° STREET ELL 1 1/4 IPS	1	28	D2772	SOLENOID VALVE 1" IPS	1
59	D2291	CHECK VALVE 1" IPS	1	29	D314F-FS-8	NIPPLE 1" IPS X 1" LG	2
60	D318A-F3-F3	UNION 1" C	1	30	D319F-G1-G1	90° UNION ELL 1 1/4 IPS	1

FOR 70° RISE

FOR 40° RISE

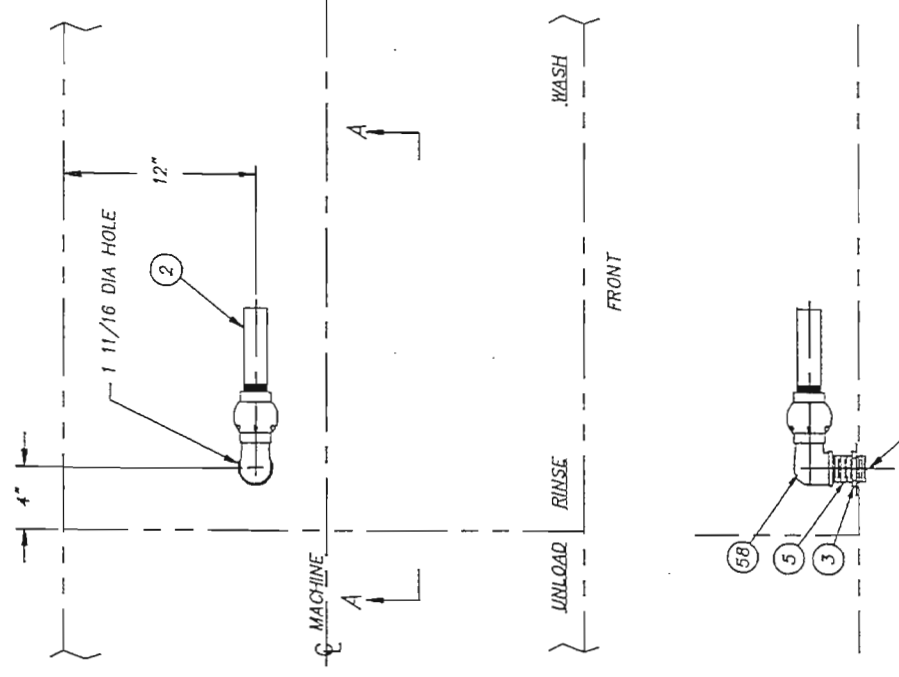

NOTE:
 1. (ITEM #7) ADD SUFFIX "NM" FOR NON-MAGNETIC MACHINES.
 2. (ITEM #47) USE PART NO. D2396 AS STANDARD AND PART NO. D2301 WHEN LOW TEMP. CUT-OFF IS SPECIFIED.

SHEET 2 OF 2

TOLERANCES	FRACTIONS ±1/64	DECIMALS	XXX ±.005	ANGLES	±1/2°	UNLESS OTHERWISE SPECIFIED
REV	ECN NO	DATE	FILE: PARTS\1462-72	TITLE	STEAM PIPING (INJECTORS) WASH TANK	NEXT ASSY DWG. NO. 1462-1
AS NOTED	SCALE	1"=8"	USED ON DEFENDER	REQD	1	1462-72
AS NOTED	SCALE	1"=8"	DEFENDER	SCALE	1"=8"	1462-72

Insinger
 Machine Company
 Philadelphia, PA 19135
 (215) 624-4800
 FAX (215) 624-6868

DRWN/DATE
 CES 2.26.97

VIEW A -- A

R.H. SHOWN - L.H. OPPOSITE

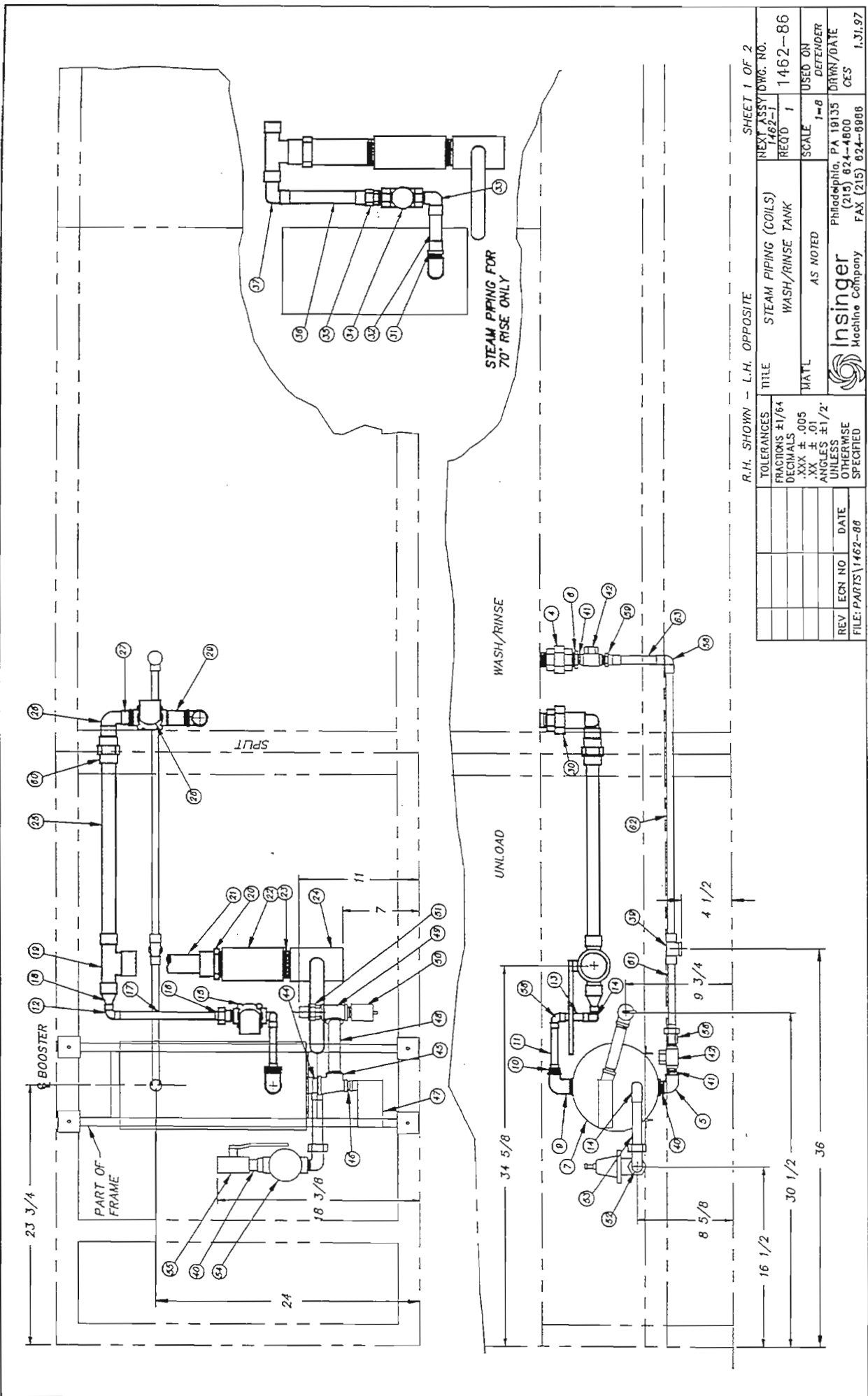

R.H. SHOWN - L.H. OPPOSITE

TOLERANCES	±1/64		
FRACTIONS			
DECIMALS			
XXX	±.005		
.XX	±.01		
ANGLES	±1/2°		
UNLESS OTHERWISE SPECIFIED			
REV	ECN NO	DATE	
FILE: PARTS\1462-86			
TITLE		STEAM PIPING (COILS)	
WASH/RINSE TANK		REQD 1	
MATERIAL		AS NOTED	
SCALE		1-8	
DEFENDER		USED ON	
Machine Company		Phildelphia, PA 19135	
		(215) 824-4800	
		FAX: (215) 624-8988	
		1.31.97	

SHEET 1 OF 2
NEXT ASSY/DWG. NO. 1462-1
REQD 1 1462-86

ITEM	PART NO.	DESCRIPTION	QTY.
1	9019-02	STEAM COIL - RINSE (MASTER)	1
2	D328F-F1	LOCKNUT 1" IPS	2
3	D314F-FA-16	NIPPLE 1" IPS X 2" ALL THD.	2
4	D318F-F1-F1	UNION 1" FIPS X 1" FIPS	1
5	D318F-E2-E1	90° RED ELL 3/4 FIPS X 1/2 FIPS	1
6	D322F-F2-D1	HEX RED BUSH 1" MIPX X 1/2 FIPS	1
7	D 2100	STEAM BOOSTER (1-2) (SEE NOTE #1)	1
8	-	-	1
9	D316F-F2-F1	90° STREET ELL 1" MIPX X 1" FIPS	1
10	D317A-E3-F2	ADAPTER 3/4 C X 1" MIPX	1
11	D207A-B6-17	COPPER TUBING 3/4 CTS X 4 1/4	1
12	D316A-E4-E3	90° STREET ELL 3/4 FTG X 3/4 C	1
13	D207A-B6-10	COPPER TUBING 3/4 CTS X 2 1/2	1
14	D316A-E3-E2	90° ELBOW 3/4 C X 3/4 MIPX	1
15	D2595	SOLENOID VALVE 3/4 IPS	1
16	D318F-E3-E2	UNION 3/4 C X 3/4 MIPX	2
17	D207A-B6-42	COPPER TUBING 3/4 CTS X 10 1/2	1
18	D323A-F4-E3	RED. BUSHING 1" FTG X 3/4 C	1
19	D320A-F3J3H3	TEE 1" C X 1" C X 1 1/2" C	1
20	D317A-H3H2	ADAPTER 1 1/2 C X 1 1/2 MIPX	1
21	D201A-B12-36	COPPER TUBING 1 1/2 CTS X 9	1
22	D2848	"Y" STRAINER 1 1/2 IPS	1
23	D314F-HC-00	NIPPLE CLOSE 1 1/2 IPS	1
24	D2849	BALL VALVE 1 1/2 IPS	1
25	D207A-K8-68	COPPER TUBING 1" CTS X 17	1
26	D316A-F3-F4	90° ELBOW 1" C X 1" C FTG	1
27	D317A-F3-F2	ADAPTER 1" C X 1" MIPX	1
28	D2772	SOLENOID VALVE 1" IPS	1
29	D314F-FS-16	NIPPLE 1" IPS X 2	1
30	D319F-F1-F1	90° UNION ELL 1" IPS	1

ITEM	PART NO.	DESCRIPTION	QTY.
31	D317A-F3-F2	ADAPTER 1" C X 1" MIPX	1
32	D207A-B8-16	COPPER TUBING 1" IPS X 4	1
33	D316A-F3-F2	90° ELBOW 1" C X 1" MIPX	1
34	-	SAME AS ITEM #28	1
35	D318A-F3-F2	UNION 1" C X 1" MIPX	1
36	D207A-B8-31	COPPER TUBING 1" CTS X 7 3/4	1
37	D316A-F4-F3	90° ELBOW 1" FTG X 1" C	1
38	-	-	1
39	D320A-E3D3E1	TEE 3/4 C X 1/2 C X 3/4 FIPS	1
40	D314F-EC-00	NIPPLE CLOSE 3/4 IPS	2
41	D314F-DC-00	NIPPLE CLOSE 1/2 IPS	2
42	D2102A	STEAM TRAP 1/2 IPS	2
43	D316A-D3-D3	90° ELBOW 1/2 C	1
44	D314F-FC-00	NIPPLE CLOSE 1" IPS	1
45	D320F-F1D1E1	TEE 1" FIPS X 1/2 FIPS X 3/4 FIPS	1
46	D322F-D2-C1	HEX RED 1/2 MIPX X 3/8 FIPS	1
47	D2396	THERMOSTAT (SEE NOTE #2)	1
48	D314A-ES-43	NIPPLE 3/4 IPS X 5 3/8	1
49	D320F-E1E1E1	TEE 3/4 IPS	1
50	D2507	PRESSURE RELIEF VALVE 3/4 IPS	1
51	-	-	1
52	D318A-E3-E2	90° UNION ELL 3/4 C X 3/4 MIPX	1
53	D207A-B6-24	COPPER TUBING 3/4 CTS X 6	1
54	D1012	PRESSURE REG & STRAINER 3/4 IPS	1
55	D2340	BALL VALVE 3/4 IPS	1
56	D318F-D3-D2	UNION 1/2 C X 1/2 MIPX	1
57	-	-	1
58	D316A-E3-E3	90° ELBOW 3/4 C X 3/4 C	2
59	D317A-E3-D2	ADAPTER 3/4 C X 1/2 MIPX	1
60	D318A-F3-F3	UNION 1" C	1
61	D207A-B4-25	COPPER TUBING 1/2 CTS X 6 1/4	1
62	D207A-B6-102	COPPER TUBING 3/4 CTS X 25 1/2	1
63	D207A-B6-19	COPPER TUBING 3/4 CTS X 4 3/4	1

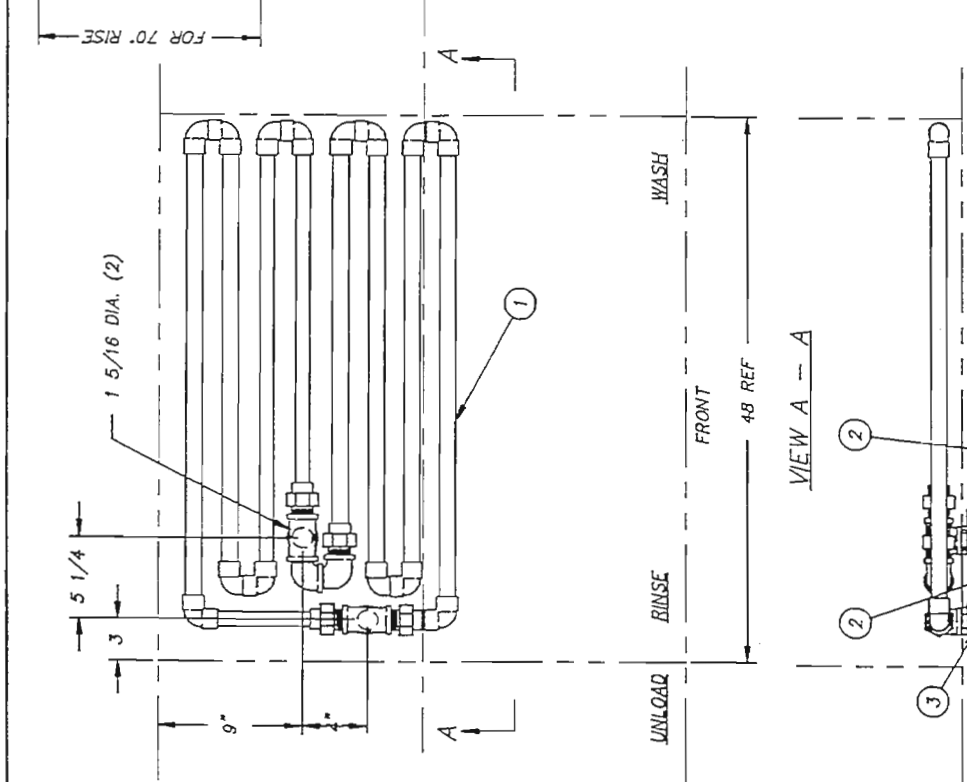

R.H. SHOWN - L.H. OPPOSITE		SHEET 2 OF 2	
TITLE	STEAM PIPING (COILS)	NEXT ASSY Dwg. NO.	1462-1
MATL	WASH/RINSE TANK	REQD	1
	AS NOTED	SCALE	1"=8'
	USED ON	DEFENDER	1
	Philadelphio, PA 19135	DRWN/DATE	CEC
	(215) 824-4800		
	FAX: (215) 824-8906		

TOLERANCES	±1/64	
FRACTIONS	±1/64	
DECIMALS	±.005	
ANGLES	±.01	
UNLESS OTHERWISE SPECIFIED		
REV	EON NO	DATE
FILE: PARTS	1462-86	

NOTE:

- (ITEM #7) ADD SUFFIX "NM" FOR NON-MAGNETIC MACHINES.
- (ITEM #47) USE PART NO. D2396 AS STANDARD AND PART NO. D2301 WHEN LOW TEMP. CUT-OFF IS SPECIFIED.

SEE PAGE 1 OF 2 FOR CONTINUATION

ITEM	PART NO.	SIZE	DESCRIPTION	QTY.
1	1372-15	A	BRACKET, TEMP. GAUGE BULB	1
2	D2470-6	-	DETERGENT METER (IF SPECIFIED)	1
3	D2470-45	-	DETERGENT DISPENSOR (IF SPECIFIED)	1
4	D2470-47	-		1
5	D2599	-	DIODE JUNCTION (SEE NOTE)	1
6	D337	-	SEAL NUT (SEE NOTE)	1
7	1089-189	A	LIQUID LEVEL FLOAT	2
8	D2-755A	A	THERMOMETER GUARD--DOUBLE (SEE NOTE)	1
9	D2-754A	A	THERMOMETER GUARD--SINGLE (SEE NOTE)	1
10	D59-217	-	LAMP 12V-25W	2
11	1454-1	B	HOOD TOP LIGHT ASSEMBLY	2
	D2470-23	A	PLUG (DETERGENT PROBE)	1

NOTE:
 ITEMS 7 & 8 ARE USED ON
 GOVERNMENT JOBS ONLY.
 ITEMS 4 & 5 USED ONLY WHEN
 COLD WATER THERMOSTAT IS
 SPECIFIED.

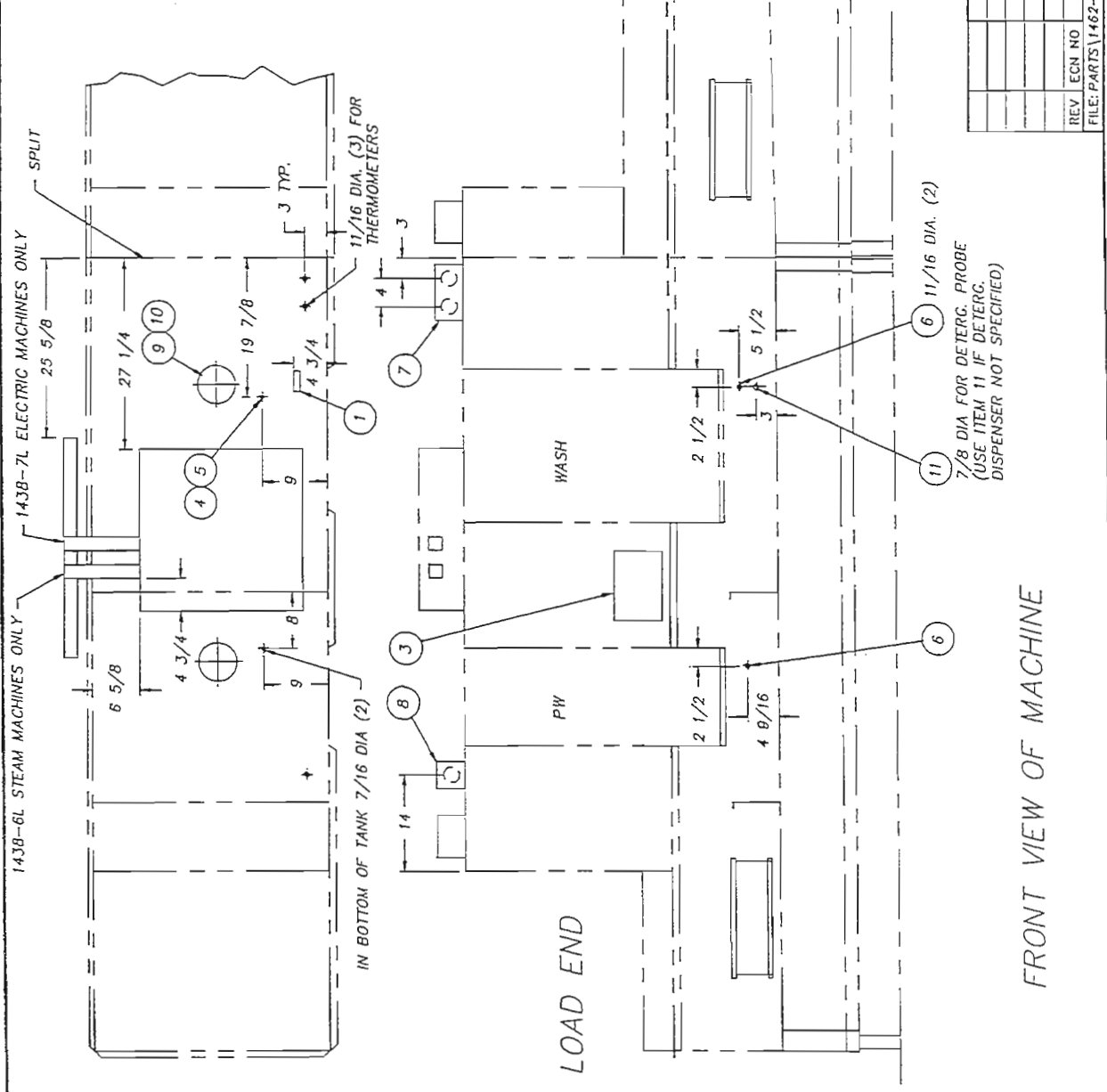

TOLERANCES		L.H. MACHINE SHOWN		SHEET 1 OF 2	
FRACTIONS	±1/64	TITLE	ACCESSORY LOCATIONS	NEXT ASSY DWG. NO.	1462-78
DECIMALS	.XXX ± .003	MATL	NOTED	REQD	1
ANGLES	±1/2°	SCALE	1=16	USED ON	DEFENDER
UNLESS OTHERWISE SPECIFIED		REV	ECN NO	DATE	
		FILE: PARTS	1462-78		
		Philadelphia, PA 19135		DRHW/DATE	
		(215) 624-4800		PC	
		FAX (215) 624-6986		12.27.96	

FRONT VIEW OF MACHINE

ITEM	PART NO.	SIZE	DESCRIPTION	QTY.
1	1372-15	A	BRACKET, TEMP. GAUGE BULB	1
2	D2470-6	-	DETERGENT METER (IF SPECIFIED)	1
3	D2470-45	-	DETERGENT DISPENSOR (IF SPECIFIED)	1
4	D2470-47	-		1
4	D2599	-	DIODE JUNCTION (SEE NOTE)	1
5	D337	-	SEAL NUT (SEE NOTE)	1
6	1089-189	A	LIQUID LEVEL FLOAT	2
7	D2-755A	A	THERMOMETER GUARD-DOUBLE (SEE NOTE)	1
8	D2-754A	A	THERMOMETER GUARD-SINGLE (SEE NOTE)	1
9	DE9-217	-	LAMP 12V-25W	2
10	1454-1	B	HOOD TOP LIGHT ASSEMBLY	2
11	D2470-23	A	PLUG (DETERGENT PROBE)	1

NOTE:
 ITEMS 7 & 8 ARE USED ON
 GOVERNMENT JOBS ONLY.
 ITEMS 4 & 5 USED ONLY WHEN
 COLD WATER THERMOSTAT IS
 SPECIFIED.

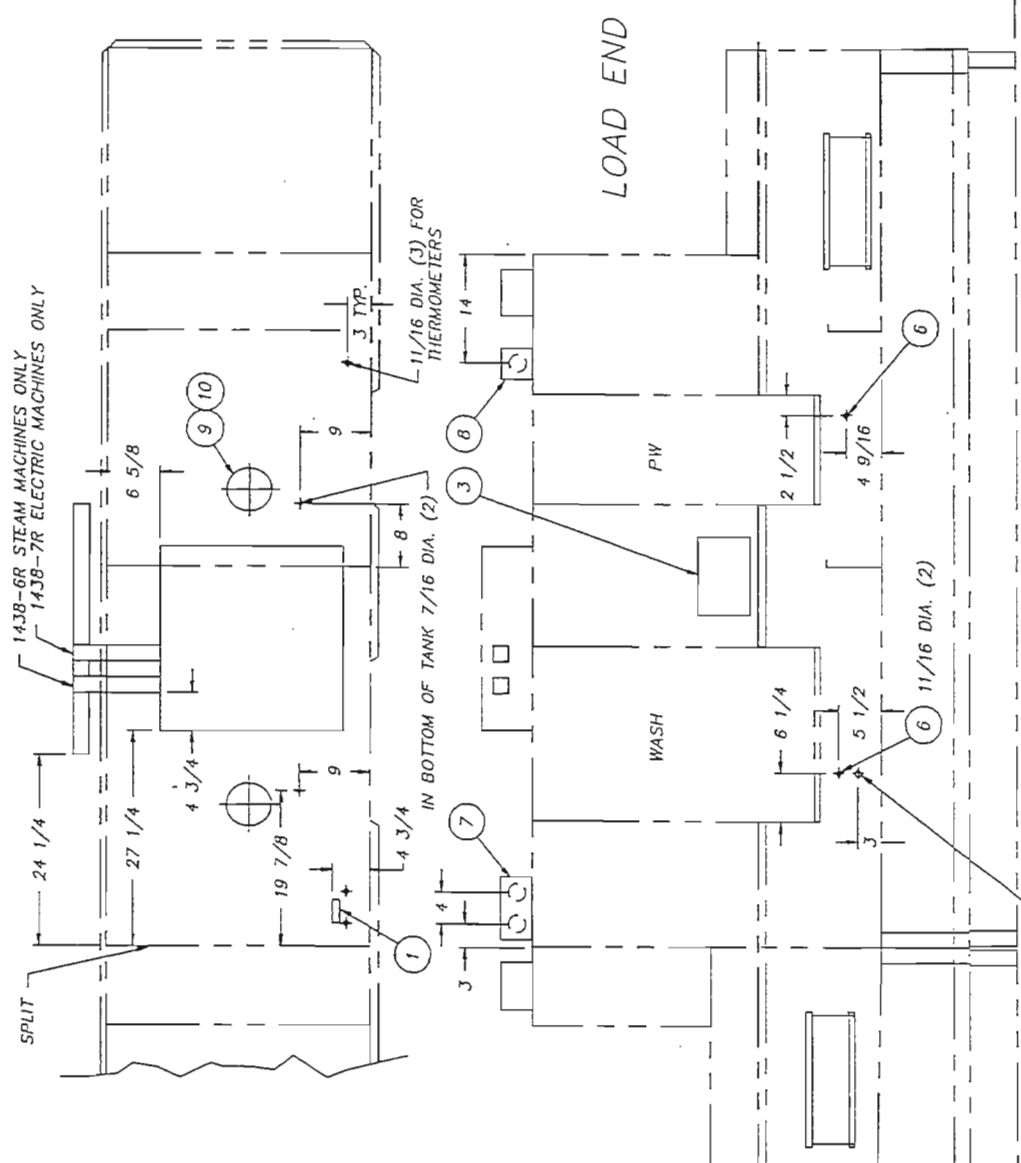

R.H. MACHINE SHOW		SHEET 2 OF 2	
TOLERANCES	TITLE	ACCESSORY LOCATIONS	NEXT ASSY DWG. NO.
FRACTIONS ±1/64	MATL	NOTED	1462-78
DECIMALS .XXX ±.005	SCALE	1=16	USED ON DEFENDER
.XX ±.01	REV	ECH NO	DATE
ANGLES ±1/2°	FILE: PARTS\1462-78		
UNLESS OTHERWISE SPECIFIED			

(USE ITEM 11 IF DETERG.
 DISPENSER NOT SPECIFIED)
 7/8 DIA. FOR DETERGENT
 PROBE

FRONT VIEW OF MACHINE

insinger
 Machine Company
 Philadelphia, PA 19135
 (215) 624-4800
 FAX (215) 624-6866
 DRWN/DATE
 PG
 12.27.96

ITEM	PART NO.	DESCRIPTION	QTY.
1	1454-2	UPPER HOUSING	1
2	1454-3	LOWER HOUSING	1
3	1454-4	GASKET-LIGHT BULB	1
4	1454-5	GASKET-HOOD TOP	1
5	1454-8	COVER	1
6	DE9-217	#1446 EMERGENCY LAMP 12V-25W	1
7	D3-547	O-RING, 4 1/8 ID X 4 1/2 OD	1
8	D309C-EF-4G	#10-32 X 1/2 WELDSTUD	4

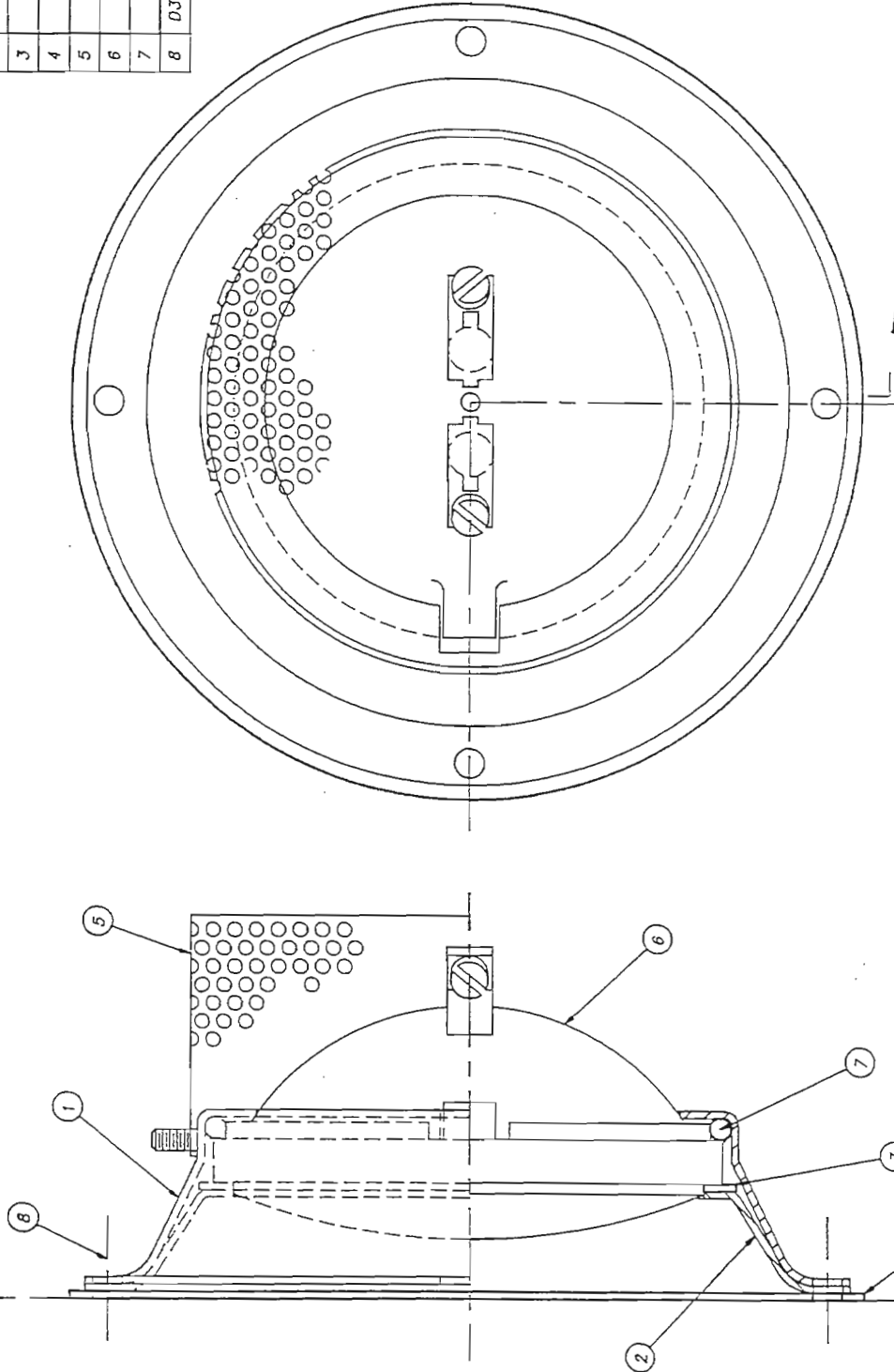

NOTES:

- 1) CUT 5 1/4 TO 5 1/2 DIA HOLE IN HOOD TOP AT EACH LAMP LOCATION
- 2) MASTER REQUIRES 3 LAMP ASSEMBLIES AS SHOWN, ONLY 1 ELECTRICAL CONTROL BOX IS REQUIRED.
- 3) STUD ITEM #5 TO ITEM #1
- 4) PUNCH ITEM #5 FOR 1/2" ELEC CONDUIT

SHEET 1 OF 2

TOLERANCES	TITLE	NEXT ASSY DWG. NO.
FRACTIONS ±1/64	ASSEMBLY-HOOD TOP LIGHT MECHANICAL COMPONENTS	REQ'D 1 1454-1
DECIMALS .XXX ±.005	MATL	SCALE 1=1
ANGLES .01	SEE ABOVE	USED ON MASTER/CLIP
UNLESS OTHERWISE SPECIFIED		PA 18135 DRAWN/DATE
		(215) 824-4800 CES
		FAX (215) 824-8888



INSINGER
Machine Company
PA 18135
(215) 824-4800
FAX (215) 824-8888
CES
2.14.98

ITEM	PART NO.	DESCRIPTION	QTY.
1	1454-6	ELEC. ENCLOSURE	1
2	1454-7	MOUNTING STRAP	1
3	DE6-9	TRANSFORMER (150VA, 24VAC)	1
4	DE9-219	FUSEHOLDER HKP-HH	1
5	DE9-218	FUSE MDL-3.2	1
6	DE9-43	CIRCUIT BREAKER, 5A	1
7	DE5-8	TOGGLE SWITCH (4X846)	1
8	DE3-9	TERMINAL BLK ASSY	1
9	1454-8	TOP-ELEC. ENCL.	1
10	1454-10	PANEL-ELEC. ENCL.	1

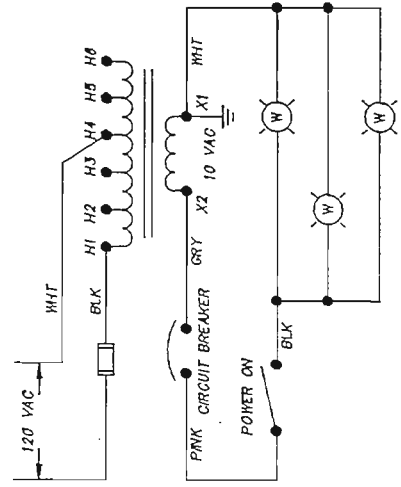
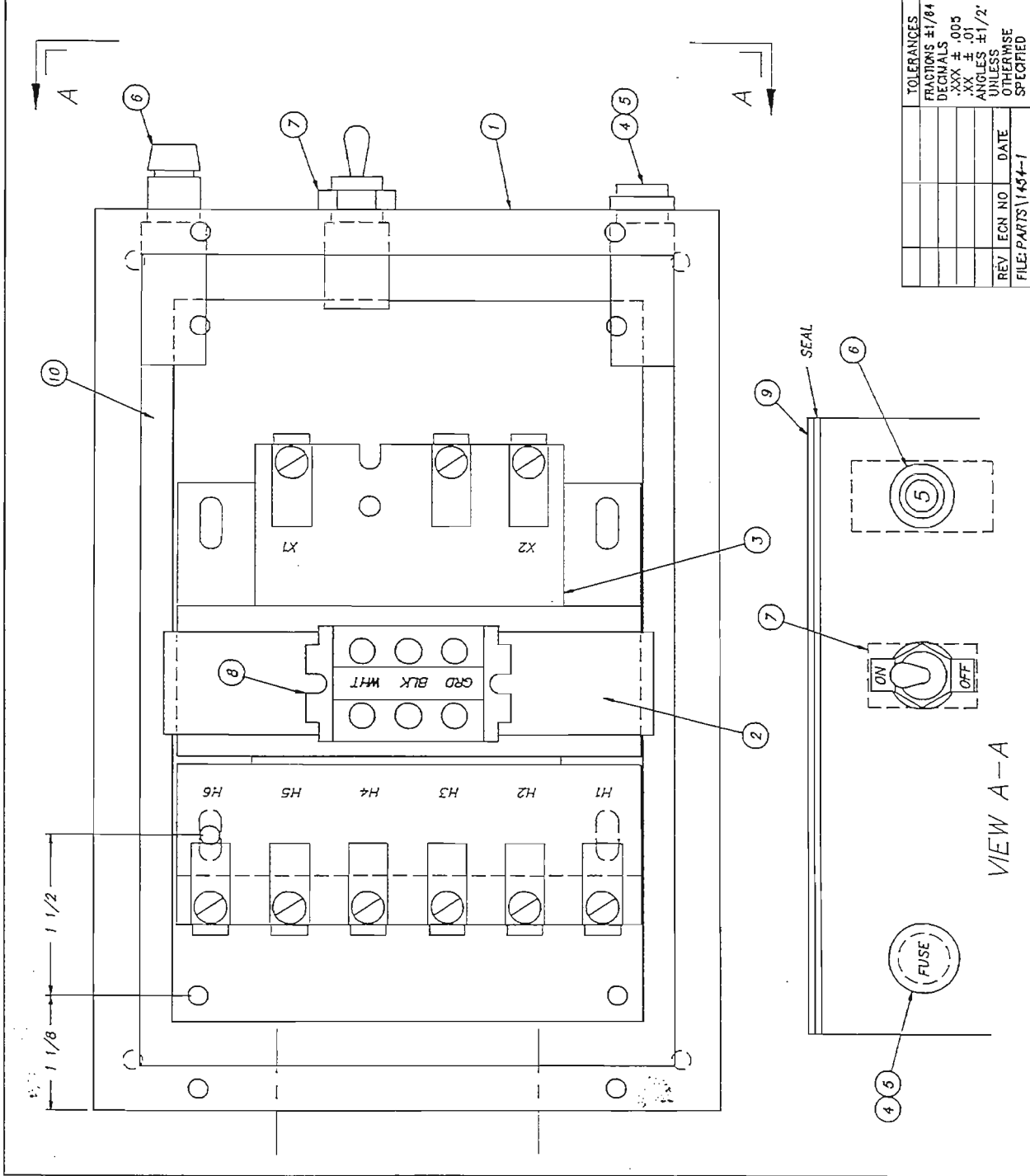

SHEET 2 OF 2

TOLERANCES	FRACIONS ±1/84	DECIMALS ±.005	ANGLES ±1/2°	UNLESS OTHERWISE SPECIFIED
REV	ECN NO	DATE		
FILE: PARTS\1454-1				
TITLE	ASSEMBLY-HOOD TOP LIGHT ELECTRICAL COMPONENTS	NEXT ASSY DRWG. NO.	1454-1	
MATL	SEE ABOVE	SCALE	1=1	USED ON MASTER/CLIP
Machine Company		Philadelphia, PA 19135		DRWN/DATE
		(215) 824-4800		CES
		FAX (215) 824-8868		1.10.98

VIEW A-A

HOURS OF OPERATION

Insinger is available to assist you and your team day or night. Our regular business hours are Monday through Friday, 8:00 AM - 5:00 PM (EST). After-hours inquiries may take longer to respond.

CONTACTS

SALES

Kim Croft
Director of Business Development
E: kcroft@insingermachine.com
D: (215) 624-4800 x124
C: (630) 400-3656

David Baysinger
Regional Sales Manager
E: dbaysinger@insingermachine.com
D: (215) 624-4800 x111

ORDERS & QUOTES

Edward Gerhard
Account Manager
E: egerhard@insingermachine.com
D: (215) 624-4800 x116

Deniece Heard
Customer Service
E: dheard@insingermachine.com
D: (215) 624-4800 x120

MARKETING

Matthew Weisbecker
Strategic Marketing Manager
E: mweisbecker@insingermachine.com
D: (215) 624-4800 x131

SERVICE & SUPPORT

Jason Striker
Parts & Service Manager
E: jason@insingermachine.com
D: (215) 624-4800 x139

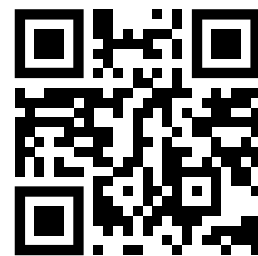

Digital Contact Cards

