



ENSIGN

Technical Manual

Ensign 40-2





Thank you for purchasing this quality Insinger product.

On the space provided below please record the model, serial number and start-up date of this unit:

Model: _____

Serial Number: _____

Start-Up Date: _____

When referring to this equipment please have this information available.

Each piece of equipment at Insinger is carefully tested before shipment for proper operation. If the need for service should arise please contact your local Authorized Insinger Service Company.

A Service Network Listing is provided on our web site, www.insingermachine.com or call Insinger at 800-344-4802 for your local authorized servicer.

For proper activation of the Insinger Limited Warranty a SureFire™ Start-Up & Check-Out Service should be completed on your machine. Refer to the Introduction section in this manual for an explanation of Insinger SureFire™ Start-Up & Check-Out Program.

Please read the Insinger Limited Warranty and all installation and operation instructions carefully before attempting to install or operate your new Insinger product.

To register your machine for warranty by phone, fax or the internet or for answers to question concerning installation, operation, or service contact our Technical Services Department:

TECHNICAL SERVICE CONTACTS	
Toll-Free	800-344-4802
Fax	215-624-6966
e-mail	service@insingermachine.com
Web site	www.insingermachine.com

TABLE OF CONTENTS

Part 1	1-6
Technical Information	
• Catalog Cut-sheet	
• Introduction	
• Warranty	
Part 2	7-8
Installation Instructions	
• Installation Drawing	
Part 3	9-14
Operating Instructions	
• Operation and Cleaning Instructions	
• Maintenance and Repair Procedures	
• Basic Service Guide	
Part 4	15-35
Electrical Schematics & Replacement Parts	



Project _____
Item _____
Quantity _____
CSI - 11400 _____
Approval _____
Date _____



Ensign 40-2 Single Tank Counter Type Dishwasher

- Automatic, space-saving, counter type single tank dishwasher with pass-thru telescoping hood
- 0.75 gallons/rack
- Capacity is 43 (16" x 16") racks per hour or 720 dishes per hour
- No venting required
- Timed wash and rinse cycle
- Fully automatic operation with power on/off button
- Cycle starts when door is closed

STANDARD FEATURES

- Tank heat: electric immersion heater
- Thermometer for wash
- Thermometer for final rinse
- Vacuum breaker
- Manifold clean-out brush
- Automatic tank fill
- Low water protection
- Detergent connection provision
- Space saving compact design
- Single point electrical connection: motor, controls, tank heat.
(Optional booster requires separate connection)
- Fully automatic operation
- Side mounted control panel (NEMA 12)
- Simplified scrap screen design
- Standard frame drip proof motor
- Door safety switch
- SureFire Start-Up and Check-Out Service

OPTIONS

- Stainless steel steam coil tank heat
- Pressure reduction valve and line strainer
- S/S frame
- Steam booster
- Remote electric booster
- Totally enclosed motor
- Plastic 16" x 16" rack (plate or silver)



Additional Information

Capacity Per Hour	43 racks 720 dishes
Tank Capacity	8.1 gallons
Motor Size	1 hp (wash)
Electric Usage	1.5 kW wash tank 6 kW booster 40° rise 12 kW booster 70° rise
Full Load Amps.	16.5
Heater	1.5 kW
Steam Consumption at 20 psi min.	6 lbs./hour tank 22 lbs./hour remote booster 40° rise 38 lbs./hour remote booster 70° rise
Final Rinse Peak Flow at 20 psi min.	4.1 gallons/minute
Final Rinse Consumption at 20 psi min.	34 gallons/hour 0.75 gallons/rack
Exhaust Hood Requirement	N/A
Peak Rate Drain Flow	9 gallons/minute
Shipping Weight	400 lbs.

SPECIFICATIONS

CONSTRUCTION- Hood and tank constructed of 16 gauge type 304 S/S. Hood unit of all welded seamless construction. All internal castings are non-corrosive lead free nickel alloy or bronze.

DOORS- Two opening operating doors. Operating doors have fingertip control, rotating on S/S bracket. Doors formed of 18 gauge S/S.

PUMP- Centrifugal type “packless” pump with a brass petcock drain. Construction includes ceramic seal and a balanced cast impeller on a precision ground stainless steel shaft, extension or sleeve. All working parts mounted as an assembly and removable as a unit without disturbing pump housing. One 1 hp motor, standard horizontal C-face frame, drip proof, internally cooled with ball-bearing construction.

CONTROLS- Side-mounted control cabinet, housing motor controls and overload protection, transformer, contactors and all dishwasher integral controls. All controls safe low voltage 24 VAC.

SPRAY SYSTEM- Wash and rinse spray systems made of 18-8 type 304 S/S pipe.

WASH- Power wash arm above with 14 high pressure action cleaning slots and a power wash arm below, with 45 nozzles. Wash arms are removable without the use of tools.

FINAL RINSE- 1 spray body above designed with 4 power rinse nozzles and 1 power rinse coil below designed with 6 nozzles.

DRAIN- Overflow assembly with skimmer is removable without use of tools for drain line inspection. Heater protected by low water level controls.

Contact Insinger Sales at 800-344-4802 for an installation drawing specific to your application.
This drawing is available on the Insinger website at www.insingermachine.com

Note: Due to product improvement we reserve the right to change information and specifications without notice.

ENSIGN 40-2**INTRODUCTION****Purpose**

The purpose of this technical manual is to provide installation, operation, cleaning and maintenance directions.

A section is provided for replacement parts.

Scope

This manual contains all pertinent information to assist in the proper installation, operation, cleaning, maintenance, and parts ordering for the Insinger Ensign 40-2.

The installation instructions are intended for qualified equipment installers. The operation and cleaning instructions are intended for the daily users of the equipment. The maintenance and parts sections are intended for qualified service and/or maintenance technicians. Replacement parts may be ordered directly from our factory or from your local Insinger Authorized Service Agency. You can speak to the Insinger Technical Services Department, 800/344-4802, or e-mail us at service@insingermachine.com. When calling for warranty information or replacement parts please provide the model and serial number of your Insinger Equipment. These important numbers should be noted in this manual on the spaces provided on the opening page.

Surefire™ Start-up & Check-out Program

Insinger is proud to offer our exclusive Surefire™ Start-up & Check-out Program to our commercial customers. This service is included in the purchase price of your new Insinger dishwasher. We will provide an authorized factory service technician for the initial start-up of your new Insinger dishwasher to ensure it is running at optimum levels from the very first pass. Please call the factory or your local Insinger Sales Representative to schedule this service.

NSF 3-2008 requirements for detergent and chemical sanitizer dispensers.

This machine must be operated with an automatic detergent dispenser and, if applicable, an automatic chemical sanitizer feeder, including a visual means to verify that detergents and sanitizers are delivered or a visual or audible alarm to signal if detergents and sanitizers are not available for delivery to the respective washing and sanitizing systems. Please see instructions for electrical and plumbing connections located in this manual and in the feeder equipment manual.

Definitions

Throughout this guide you will find the following terms: **WARNING, CAUTION, & NOTE.**

WARNING indicates potential physical danger.

CAUTION indicates potential equipment damage.

NOTE indicates helpful operating hints or tips.

You will visually be able to identify each as shown below:

**NOTE:**

Indicates helpful operating hints or tips.

**WARNING:**

Indicates potential physical danger.

CAUTION:

Indicates potential equipment damage.

Ensign 40-2 Counter Type Dishwasher**Safety Summary**

The following are general safety precautions that are not related to any specific procedures. These are recommended precautions that personnel must understand and apply during many phases of operation and maintenance.

Keep Away From Live Circuits

Operating personnel must at all times observe all safety regulations. Do not replace components or make adjustments inside the equipment with the high voltage supply turned on. Under certain conditions, dangerous potentials may exist when the power control is in the off position. To avoid casualties, always remove power, red tag machine and ground a circuit before touching it.

Do Not Service or Adjust Alone

Under no circumstances should any person reach into or enter the enclosure for the purpose of servicing or adjusting the equipment except in the presence of someone who is capable of rendering aid.

Resuscitation

Personnel working with or near high voltages should be familiar with modern methods of resuscitation. Such information may be obtained from the Bureau of Medicine and Surgery.

INSINGER MACHINE COMPANY LIMITED WARRANTY

Insinger Machine Company, Inc. (Insinger) hereby warrants to the original retail purchaser of this Insinger Machine Company, Inc. product, that if it is assembled and operated in accordance with the printed instructions accompanying it, then for a period of either 15 months from the date of shipment from Insinger or 1 year (12 months) from the date of installation or start-up that said Insinger product shall be free from defects in material and workmanship. Whichever one of the two aforesaid limited warranty time periods is the shortest shall be the applicable limited warranty coverage time period.

Insinger may require reasonable proof of your date of purchase; therefore, you should retain your copy of invoice or shipping document.

This limited warranty shall be limited to the repair or replacement of parts which prove defective under normal use and service and which on examination shall indicate, to Insinger's satisfaction, they are defective. Any part that is claimed to be defective and covered by this limited warranty must be returned to Insinger. An RMA# must be obtained from the Insinger Warranty Department before returning any material. Return may be done through an Authorized Service Agency. Furnish serial number of machine and RMA # with shipment and send to:

Insinger Machine Company
6245 State Road
Philadelphia, PA 19135-2996

If Insinger's inspection confirms the defect and the claim, Insinger will repair or replace such part without charge and return it to you freight or postage prepaid.

This limited warranty does not cover any failure or accident, abuse, misuse, alteration, misapplication, improper installation, fire, flood, acts of God or improper maintenance or service,

or failure to perform normal and routine maintenance as set out in the instruction booklet (operating instructions) or for improper operation or failure to follow normal operating instructions (as set out in the instruction booklet). Insinger is not responsible nor liable for any conditions of erosion or corrosion caused by corrosive detergents, acids, lye or other chemicals used in the washing and or cleaning process.

Service must be done by either Insinger Appointed Service Agencies or agencies receiving prior authorization from Insinger.

All warranty work must be done during normal working hours, unless purchaser receives prior authorization from Insinger.

There are no other express warrants except as set forth herein and any applicable implied warranties of merchantability and fitness are limited in duration to the period of coverage of this express written limited warranty. This limited warranty supersedes all other express warranties, implied warranties of merchant-ability and fitness or limited warranties as of this date, January 1, 1998. Some states do not allow limitation on how long an implied warranty lasts so this limitation may not apply to you.

Insinger is not liable for any special, indirect or consequential damages. Some states do not allow the exclusion or limitation of incidental or consequential damages, so this limitation nor exclusion may not apply to you.

Insinger does not authorize any person or company to assume for it any other obligation or liability in connection with the sale, installation, use, removal, return or replacement of its equipment: and no such representations are binding on Insinger.

INSINGER MACHINE COMPANY LIMITED WARRANTY- COMMERCIAL MARINE USE

Insinger Machine Company, Inc. (Insinger) hereby warrants to the original retail purchaser of this Insinger Machine Company, Inc. product, that if it is assembled and operated in accordance with the printed instructions accompanying it (installation manual), then for a period of 15 months from the date of installation on board the vessel, that said Insinger product shall be free from defects in material and workmanship.

Insinger may require reasonable proof of your date of equipment install, therefore, you should retain your copy of invoice or shipping document.

This limited warranty shall be limited to the replacement of parts which prove defective under normal use and service and which on examination shall indicate, to Insinger's satisfaction, they are defective. Any part that is claimed to be defective and covered by this limited warranty must be returned to Insinger. Furnish serial number of machine with shipment and send to:

Insinger Machine Company, Inc.
6245 State Road
Philadelphia, PA 19135-2996

If Insinger's inspection confirms the defect and the claim, Insinger will repair or replace such part without charge and return it to you freight or postage prepaid. If part damages are not covered, Insinger will contact the customer and advise.

If a factory trained authorized technician is required to repair or replace defective parts or material during the 18 month warranty period, the cruise line will be responsible for the payment of travel expense and a minimum of four hours labor.

Labor will be billed to the customer at a reduced rate of \$40.00 per hour. If sailing with a vessel is required, then an eight hour per day minimum will apply.

This limited warranty does not cover accident, abuse, misuse, alteration, misapplication, improper installation, fire, flood, or improper maintenance or service, or failure to perform normal and routine maintenance as set out in the instruction booklet (operating instructions) or for improper operation or failure to follow normal operating instructions (as set out in the instruction booklet).

Insinger is not responsible nor liable for any conditions of erosion or corrosion caused by corrosive detergents, acids, lye or other chemicals used in the washing, caring and or cleaning process.

Warranty service must be done by either Insinger Appointed Service Agencies or agencies, customers galley engineers receiving prior authorization from Insinger.

There are no other express warrants except as set forth herein and any applicable implied warranties of merchantability and fitness are limited in duration to the period of coverage of this express written limited warranty. This limited warranty supersedes all other express warranties, implied warranties of merchantability and fitness or limited warranties as the above date.

Insinger does not authorize any person or company locally or overseas to assume for it any other obligation or liability in connection with the sale, installation, use, removal, return or replacement of its equipment; and no such representations are binding on Insinger.

INSTALLATION INSTRUCTIONS**Ensign 40-2 Counter Type Dishwasher****Machine Specifications**

Insinger model Ensign 40_2 stainless steel counter type dishwasher with automatic timing of the wash and rinse cycle with either electric immersion heater for tank heat and electric heat exchange booster for rinse or steam coils for tank heat and steam heat exchange booster for rinse.

ELECTRICAL REQUIREMENTS

(specified by end-user):

1/2 HP, 110-120/240 single phase or 208-220/460VAC three phase, 60 cycle. Motor operates through a timed cycle controller. Rinse operates through a 24VAC solenoid valve actuated by the timed cycle controller.

Feed:

Side door loading, counter top installation. Direction of feed specified by end-user.

Tools:

No special tools required for cleaning or maintenance. Cleanout brush provided for the spray pipes. Machine must be welded into the tabletop (unless provided with a stand).

Dishbaskets:

16" square plastic inserts.

Placement

Carefully uncrate machine. Take caution not to damage components which may be mounted on the top or sides of the machine. Set unit in the table cut-out. Refer to installation drawing in this section for table cut-out dimensions. Weld the dish machine into the table. Install temp gauges.

Electrical Connections

Connect electrical lines sized for the correct voltage, current and phase of the machine. These should agree with the machine requirements indicated on the nameplate and labels on the control panel. A single-point electrical connection is provided for the pumps, control circuit, and wash tank heater. If an electric booster is provided, connect power directly to the booster.

CAUTION:

Connections must be made to a circuit breaker or fused disconnect as provided by the end-user and required by local codes.

A laminated wiring diagram is inside the control panel.

Chemicals

Upon the completed installation of the dishwasher, contact a local detergent/chemical supplier for the correct chemicals for your soil load and geographical area.

Electrical connection points for the detergent dispenser and rinse injector are located inside the control panel. Refer to the wiring diagram for this machine for the proper connection points.

Dispensers may be connected on either the primary voltage side of the machine or the 24VAC control

CAUTION:

When connecting on the 24VAC control voltage side of the transformer, total VA **must not** exceed 50VA.

Tabling

Load and unload tables should be pitched towards the machine to return excess water into the machine.

Initial Start-Up Adjustments**Tank Overfill Adjustment**

1. Locate tank overfill timer in the control panel.
See the control panel layout drawing located in Section 4, Electrical Schematic and Replacement Parts.
2. The overfill timer starts timing when the upper level float is actuated. Adjust the overfill timer potentiometer to turn the tank fill solenoid off when the water level is 1/4" below the lip of the overflow tube.
3. The timer has a built in dwell timing delay of 5 seconds (nominal to dampen float bounce caused by tank water motion).

Final Rinse Pressure Adjustment

1. The final rinse pressure must be adjusted to 20PSI. This is done by adjusting the pressure regulator.

Insinger dishmachines are user-friendly, making them the easiest dishmachines on the market to operate and maintain. By following these operating procedures your Insinger dishwasher will give you years of trouble free service.

OPERATION INSTRUCTIONS

1. Ensure drain overflow tube is in place. Close all tank drain valve. One drain is provided for each tank of the dishmachine.
2. Check for proper installation and cleanliness of all internal, removable components such as suction strainers, scrap screens, and spray manifolds.
3. Ensure all water & steam lines are open. Ensure electrical circuits are on.
4. Close machine doors.

**NOTE:**

An interlock is provided to shut the machine down if the doors are open, therefore the machine will not run if the doors are opened.

5. Press the power switch to the ON position. The switch will light up red when on. The machine will fill the tank, run through a complete wash/rinse cycle and shut-off.
6. When the tank is full the tank heat will operate automatically. Proper wash tank temperature is 160° F minimum. Proper final rinse temperature is 180° F minimum at 20 PSI ± SPSI, while in the final rinse cycle.

CAUTION:

To ensure proper operation of the auto tank fill feature and the tank heaters, the tank level floats **MUST** be cleaned daily.

7. Open doors.
8. Insert a rack of soiled dishware in machine and lower doors. Depress the cycle start button, machine will wash and rinse automatically. When the rinse indicator light goes off the machine cycle is complete.

CAUTION:

Overloading racks will minimize the proper cleaning of ware.

**WARNING:**

Do not open the doors during the wash/rinse cycle as hot water is being sprayed. An interlock is provided to stop the wash/rinse cycle if the doors are opened but hot water may spray out if doors are opened too quickly.

9. Open doors and remove rack of clean ware. For continuous operation repeat steps 7-9.
10. Upon completion of ware cleaning press the power switch to the "OFF" position. The switch light will go off.
11. Refer to the cleaning procedures for proper clean-up of the dishmachine.
12. A switch on the control panel labeled "De-lime" is provided for use when de-liming the machine. When activated, this switch will keep the machine in an indefinite wash cycle.
13. A switch on the control panel labeled "Heavy Cycle" will activate the extended wash cycle for heavily soiled ware.
14. Report any unusual occurrences to qualified service personnel.

The following cleaning procedures should be done daily, at the end of the shift.

Cleaning Procedures, Daily

1. Turn the power switch to off.
2. Drain unit by removing overflow tube.
3. Metal surfaces may be hot- use caution.
4. Remove all internal removable parts including spray manifolds, scrap screens, drain overflow tube and suction strainer.
5. Remove the end caps from the spray manifolds and clean with the brush provided. Flush the manifolds.
6. Flush scrap screens
7. Clean drain overflow tube.
8. Clean suction strainer of build-up

CLEANING PROCEDURES (continued)

9. Clean the tank level float with a plastic abrasive pad (do not use steel wool).
10. Final rinse nozzles should be cleaned of matter clogging the jet spray.
11. The doors should be left open to allow drying of interior surfaces.

**NOTE:**

Improper cleaning of the suction strainers will cause the pumps to cavitate. This will cause poor washing results.

CAUTION:

Level floats must be cleaned daily. Build-up of grease and dirt will cause faulty operation of the tank fill heating system.

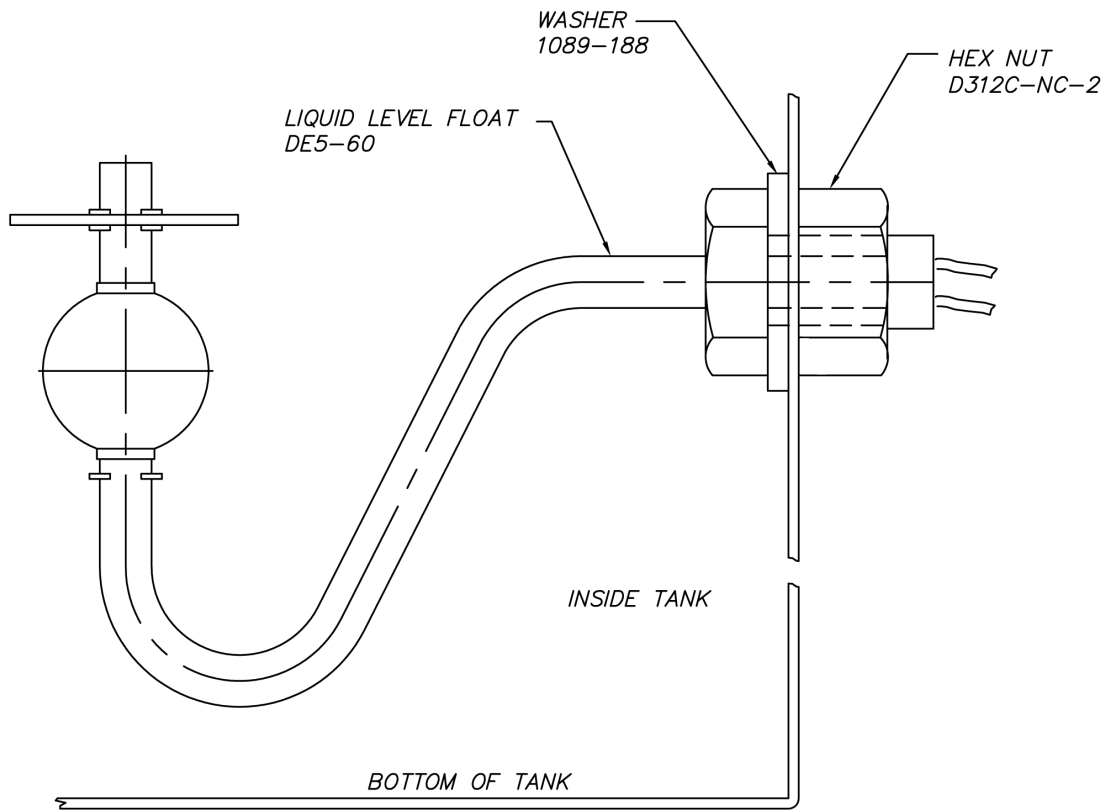

The following is a basic guide for the repair and replacement of common dishwasher parts. Refer to the Basic Services Guide for troubleshooting tips.

MAINTENANCE REQUIREMENTS

Daily

1. Refer to the operations and cleaning instructions provided in this manual for daily cleaning procedures.

Weekly

1. The entire machine should be wiped down using an industrial grade stainless steel cleaner.
2. Under the supervision of your detergent supplier the machine interior must be properly de-limed.

**NOTE:**

The water quality in some areas requires de-liming to be done more frequently. Contact your detergent supplier for recommended de-liming frequency.

Quarterly

1. Remove and clean the strainer screens on the water and steam lines. If the screens cannot be cleaned, replace.
2. Inspect the condition of the solenoid valve seats, and diaphragms. Replace where necessary.

MAINTENANCE PROCEDURES

Solenoid Valve Disassembly

1. Disconnect the power supply to the machine. Turn off the water supply.
2. Remove cap on top of the coil. Remove the coil.
3. Remove the 4 hex bolts and lift bonnet from valve body. Note positioning of spring and plunger.
4. Remove main piston.
5. Inspect for dirt, wear or lime build-up. Clean or replace as required.
6. Reassemble in reverse of disassembly.

Liner Strainer Disassembly

1. Shut off water or steam supply.
2. Remove large hex nut on bottom of strainer body.
3. Remove strainer screen. Inspect and clean or replace as necessary.
4. Reassemble in reverse of disassembly. Water flow must be same direction as arrow on line strainer body. Use new gaskets to insure a tight seal.

Pump Disassembly

1. Before disassembling pump ensure there are no obstructions in the pump intake. Remove and clean the suction strainer (inside tank). See dwg. SK-2462.

**NOTE:**

It is not necessary to remove the pump housing from the machine to disassemble.

2. Remove the pump motor and impeller by removing the 4 hex bolts attaching them to the pump housing.
3. Repair or replace the pump parts as required.
4. Reassemble in reverse of disassembly.

Immersion Heater Replacement

1. The immersion heater **MUST** be completely submerged at all times. If this is not the case contact a qualified service technician. The heated surface should never be in contact with sludge. See dwg. SK-4703.
2. Remove the housing covering the wiring terminations. Disconnect the immersion heater wires.
3. Remove the immersion heater by loosening and removing the large hex nut.
4. Install in reverse of removal.



NOTE:
Use plumbers putty as gasketing around the immersion heater to minimize leaks.

Tank Heat Temperature Adjustment

1. A temperature control board is provided in the control panel for easy adjustment of tank temperature. Though tank temperature is adjusted during the machines factory test it is sometimes necessary to re-adjust the temperature at start-up.
2. Locate the temperature control board. Use the control panel layout drawing located in Section 4, Electrical Schematic and Replacement Parts.
3. Adjust the tank temperature to the desired temperature by turning the potentiometer located on the temperature control board. An arrow on the potentiometer indicates increase.
4. If the temperature does not change refer to Troubleshooting Tank Temperatures in the next section.

Troubleshooting Tank Temperatures Electric Heat

1. If temperature does not change check the temperature control board (P/N DE9-251) proper operation. If the temperature control board is faulty, replace.
2. Verify tank heat contactor is working correctly. If not, replace.
3. Verify all immersion heaters are working properly and not limed. If not, replace.

Steam Heat

1. If temperature does not change check the temperature control board (P/N DE9-251) proper operation. If the temperature control board is faulty, replace.
2. Verify steam pressure per machine specifications.
3. Verify steam trap is not clogged. If so, replace.

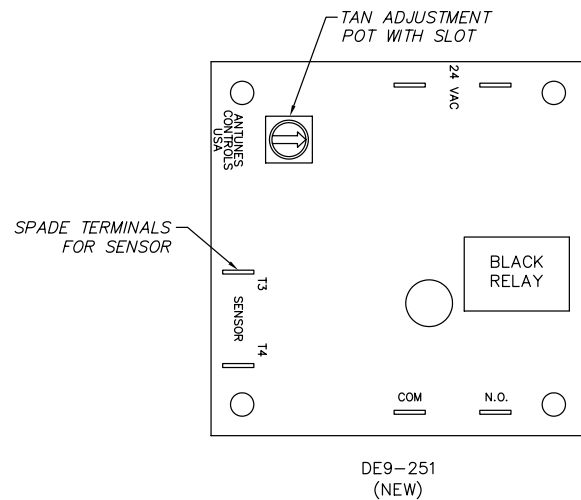

Motor Overloads

All motors used on Insinger Machines are provided with motor overloads. Motor overloads are adjusted when the machines are factory tested. Should it be necessary to adjust the motor overloads in the field first verify the motor current draw for the voltage the machine is using.

Using the Control Panel Component Layout Dwg. located in Section 4 to identify the overload, adjust by turning the dial to the appropriate AMP draw.

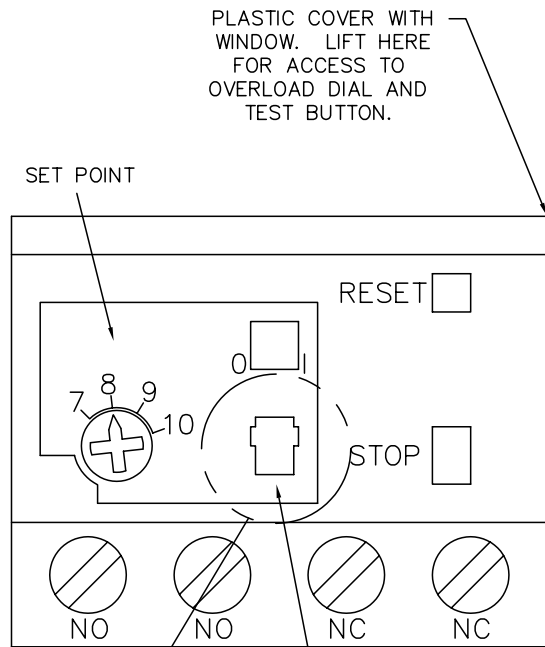

TO CHANGE FROM MANUAL TO AUTO RESET:

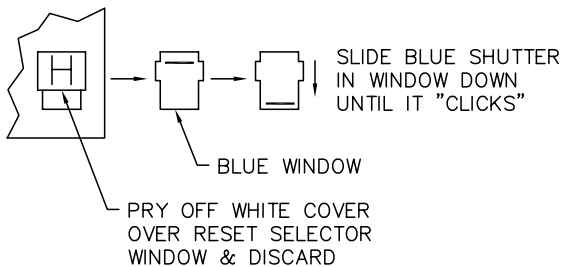

SKETCHA\SK-3829

OVERLOAD RELAY SETTINGS

Level System

The level control system consists of one overflow timer (P/N DE7-35) and one level float (P/N DE5-60) per tank.

When the system is powered-up, the tank(s) will begin to fill (assuming no water is in the tanks).

When the level float is actuated, the overflow timer begins to time-out and continues the filling process until the tank(s) is full.

Also consists of a Hi-Limit switch in electric heated unit. Hi-Limit in series with float. Inspect Hi-Limit for damage. Be careful when cleaning not to damage it.

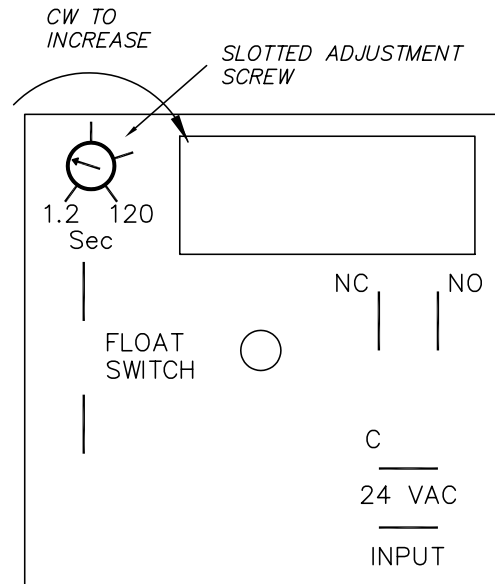

NOTE:

The overflow timer **MUST** be adjusted during initial start-up. Adjustment depends on water fill pressure. The water level **MUST** be 1/4" below the lip of the overflow tube. Adjust by increasing or decreasing the potentiometer on the level timer.



NOTE:

Dirty level floats will cause the tank heat to energize with no water in the tanks. **LEVEL FLOATS MUST BE CLEANED DAILY.**

Basic Service Guide

BASIC SERVICE GUIDE		
SYMPTON	POSSIBLE CAUSE	SOLUTION
1. Machine will not operate	A. No power B. Blown fuse or tripped breaker C. Motor overloads tripped D. Door magnet broken or missing E. Door switch on manual	A. Check power supply B. Replace fuse; reset breaker C. Reset overload D. Replace E. Switch to automatic
2. Tank will not hold water	A. Drain overflow not seated or installed B. Pump petcock opened	A. Reseat or install drain overflow B. Close pump petcock
3. Tank fill beyond overflow	A. Obstruction in overflow tube or drain line B. Float dirty or bad	A. Remove obstruction B. Clean and/or replace
4. Water leaks around door	A. Doors not seating B. Clogged spray pipe C. Missing end caps on spray arms	A. Reseat doors B. Clean spray pipe with brush provided C. Install end caps
5. Weak or ineffective spray	A. Clogged spray pipe B. End cap missing on spray arms C. Manifolds not installed properly D. Pump rotation reversed E. Suction strainer clogged	A. Clean spray pipe with brush provided B. Install endcap C. Ensure proper placement of upper and lower pipes D. Arrow on pump housing indicates direction, correct strainer E. Clean suction strainer
6. Weak or ineffective final rinse spray	A. Lime deposits in spray nozzles B. Low water pressure C. Clogged line strainer D. Closed water supply valve E. Water valve/diaphragm	A. Clean or replace nozzles B. Adjust to 20PSI C. Remove line strainer and clean D. Open ball valve E. Replace diaphragm
7. Water hammer	A. Excessive water line pressure	A. Install water hammer valve
8. Machine vibrates or is noisy	A. Pump rotation reversed B. Broken impeller	A. Arrow on pump housing indicates direction, correct electrically B. Inspect or replace impeller
9. Final rinse will not shut off	A. Float dirty or bad B. Solenoid valve still powered-up C. Final rinse solenoid valve clogged D. Diaphragm worn	A. Clean and/or replace B. Check final rinse actuating circuit for proper operation C. Disassemble valve and clean internal parts of scale or replace D. Replace with solenoid valve repair kit
10. Tank not filling/tank heat coming on with no water in tank	A. Level float dirty B. Level control system not working	A. Clean level float B. Troubleshoot level control circuit
11. Tank temperature too low/high	A. Thermostat not adjusted B. Heat circuitry not working C. Electric heat—power turned off D. Electric heat—immersion heaters limed E. Steam heat—steam turned off F. Steam heat—not enough steam G. Steam heat—condensate traps clogged	A. Adjust thermostat B. Troubleshoot circuitry C. Check circuit breakers D. De-lime machine E. Turn steam on F. Adjust steam pressure per machine specs G. Clean or replace condensate traps

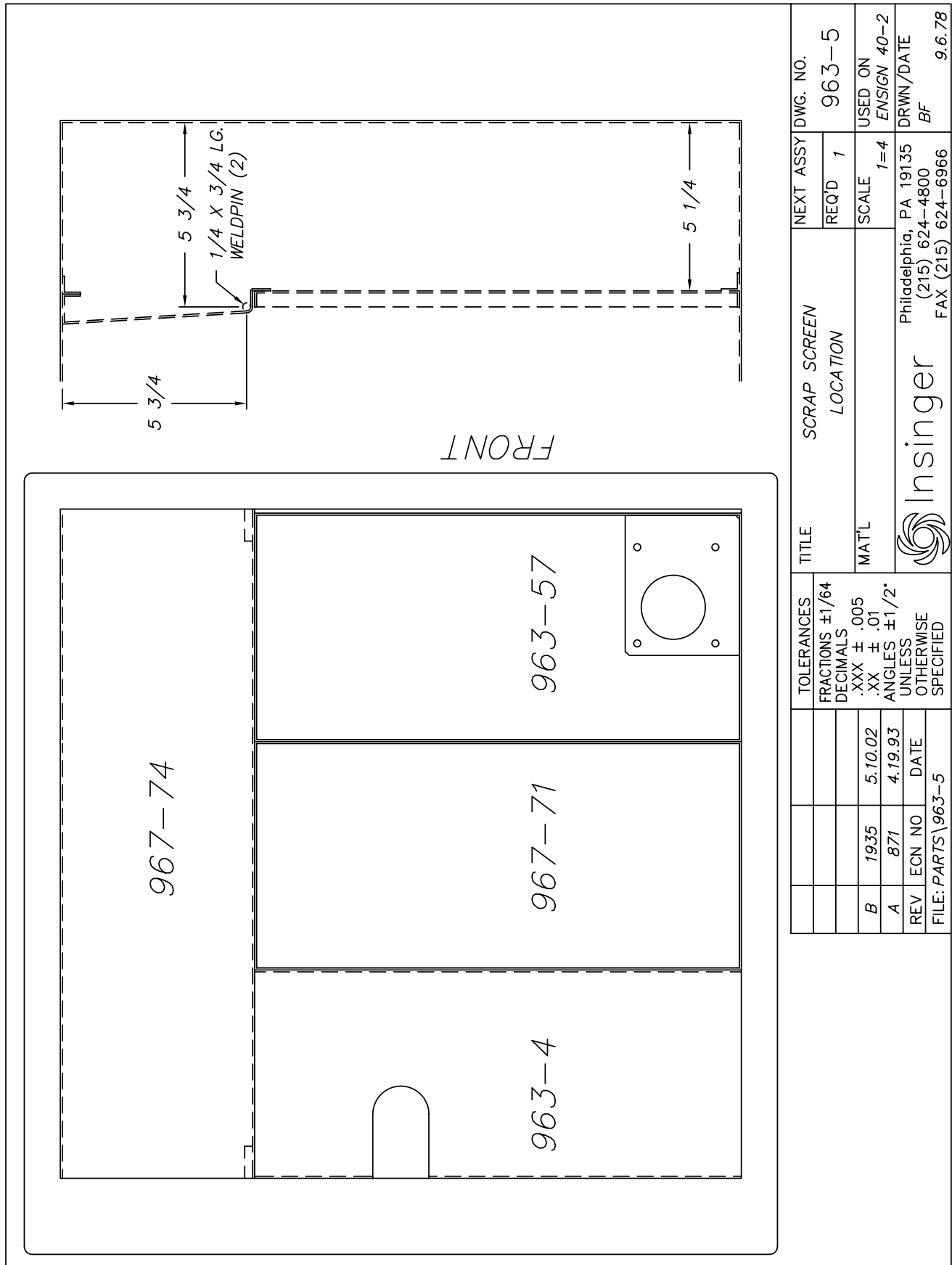

TITLE		SCRAP SCREEN LOCATION		NEXT ASSY DWG. NO.	
TOLERANCES		REQ'D		963-5	
FRACTIONS ±1/64		1		SCALE	
DECIMALS		SCALE		1=4	
.XXX ± .005		MATERIAL		USED ON	
.XX ± .01		MAT'L		ENGIN 40-2	
ANGLES ±1/2°		Philadelphia, PA 19135		DRWN/DATE	
UNLESS OTHERWISE SPECIFIED		(215) 624-4800		BF	
REV		Insinger		FAX (215) 624-6966	
ECN NO		9.6.78			
DATE					
FILE: PARTS\963-5					

ITEM	PART NO.	DESCRIPTION	QTY.
1	963-8B	DISCHARGE TUBE ASSEMBLY	1
2	963-11	DISCHARGE LINE NIPPLE	1
3	D326J-H1	LOCK NUT 1 1/2 IPS	1
4	963-12B	MANIFOLD ASSEMBLY	1
5	199-42	UPPER SPRAY PIPE	1
6	D2-554-2A	PLUG 3/4-10 UNC W/HOLE	7
7	1436-4*	CAPTIVE THUMB SCREW 3/8-16	2
8	D309C-HC-5K	SET SCREW ALLEN HD., FULL DOG PT.	1
9	D312C-HC-5	LOCK NUT 5/16-18 S.S.	1
10	963-35	GASKET	1
11	963-15	BRACKET	1
12	5320-00545	WELD STUD #10-32 x 3/8 LG.	4
13	5325-00549	LOCK NUT #10-32 S.S.	4
14	SK-4753-1	WIRE ROPE SUB ASSY X 3 1/2" LG	1
15	5320-00555	WELD STUD, S/S, #6-32 X 1/4	1
16	5325-00556	SEAL NUT, #6-32	2
17	D309C-CC-40	PAN HD SCREW, #6-32 X 1/2	1

* CAPTIVE THUMBSCREW NOT REPLACEABLE

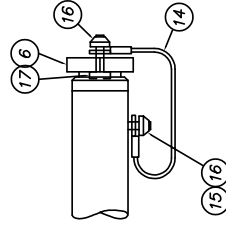
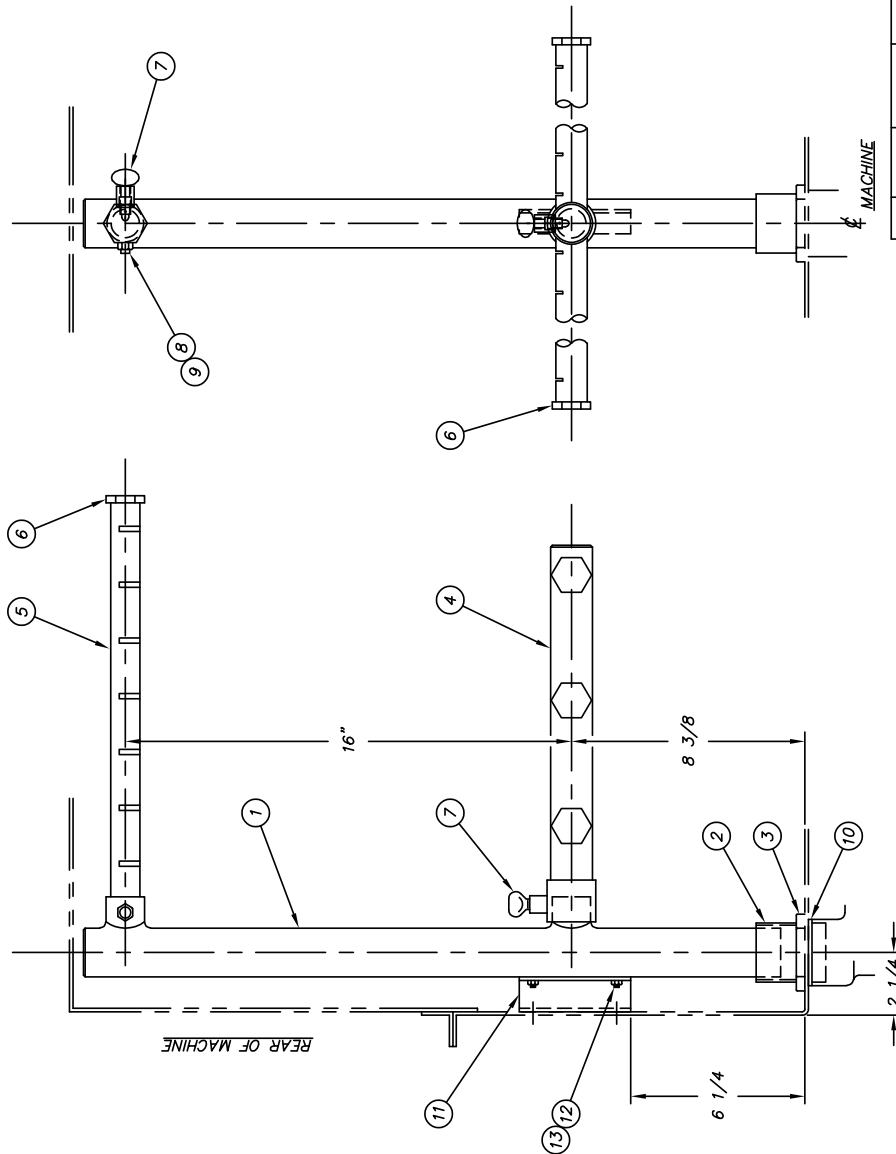

USED ON: WAFFLE HOUSE 40-2
SINCE 2006

TOLERANCES:	TITLE	NEXT ASSY DWG. NO.
FRACTIONS ±1/64	DISCHARGE LINE ASSEMBLY	963-7B
DIMENSIONS ±.005	MATL	SCALE 1=4
ANGLES ±1/2°	NOTED	USED ON SEE ABOVE
OTHERWISE SPECIFIED		DRWN/DATE
		CEC

SEE #963-7A FOR 455A5 & EARLY 40-2

Insinger
Philadelphia, PA 19135
(215) 624-4800
FAX (215) 624-6966

9.13.16

ITEM	PART NO.	DESCRIPTION	QTY.	ITEM	PART NO.	DESCRIPTION	QTY.
8	D309C-JC-12A	HHCS 3/8-16 X 1 1/2 LG	4	1	963-38	SUCTION STRAINER FLANGE	1
9	5325-00539	SEALNUT 3/8-16	4	2	D2-541	SUCTION STRAINER	1
10	D313A-J1	COPPER WASHER 3/8	4	3	D514	GASKET	1
				4	D134	FLANGE	1
				5	D207E-K12-10	TUBE, 1.63" LG 1-1/2" SCH 40 S/S	1
				6	4805-01332	ELBOW, 90 DEG 1-1/2" SCH-40 S/S	1
				7	D3082	NIPPLE, 1-1/2" X 1-1/2" TOE	1

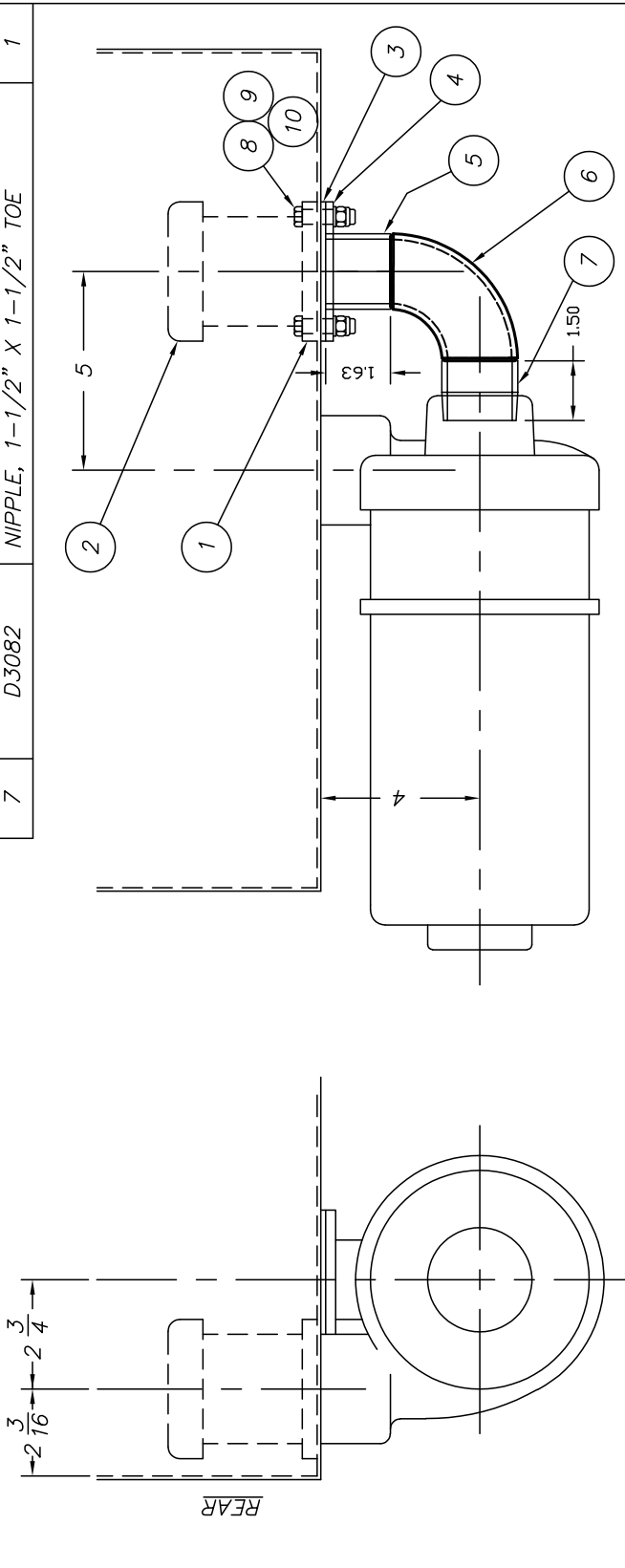

TOLERANCES	FRACCTIONS	DECIMALS	ANGLES
	±1/64	.XXX ±.005	±1/2°
		.XX ±.01	UNLESS OTHERWISE SPECIFIED

TITLE	SUCTION LINE ASSEMBLY	NEXT ASSY SK-2342	DWG. NO.
MAT'L	AS NOTED	REQD 1	963-18
		SCALE 1=4	USED ON ENSIGN 40-2

 Insinger Philadelphia, PA 19135 (215) 624-4800 FAX (215) 624-6966		DRWN/DATE EMM 8.7.02
---	--	-------------------------

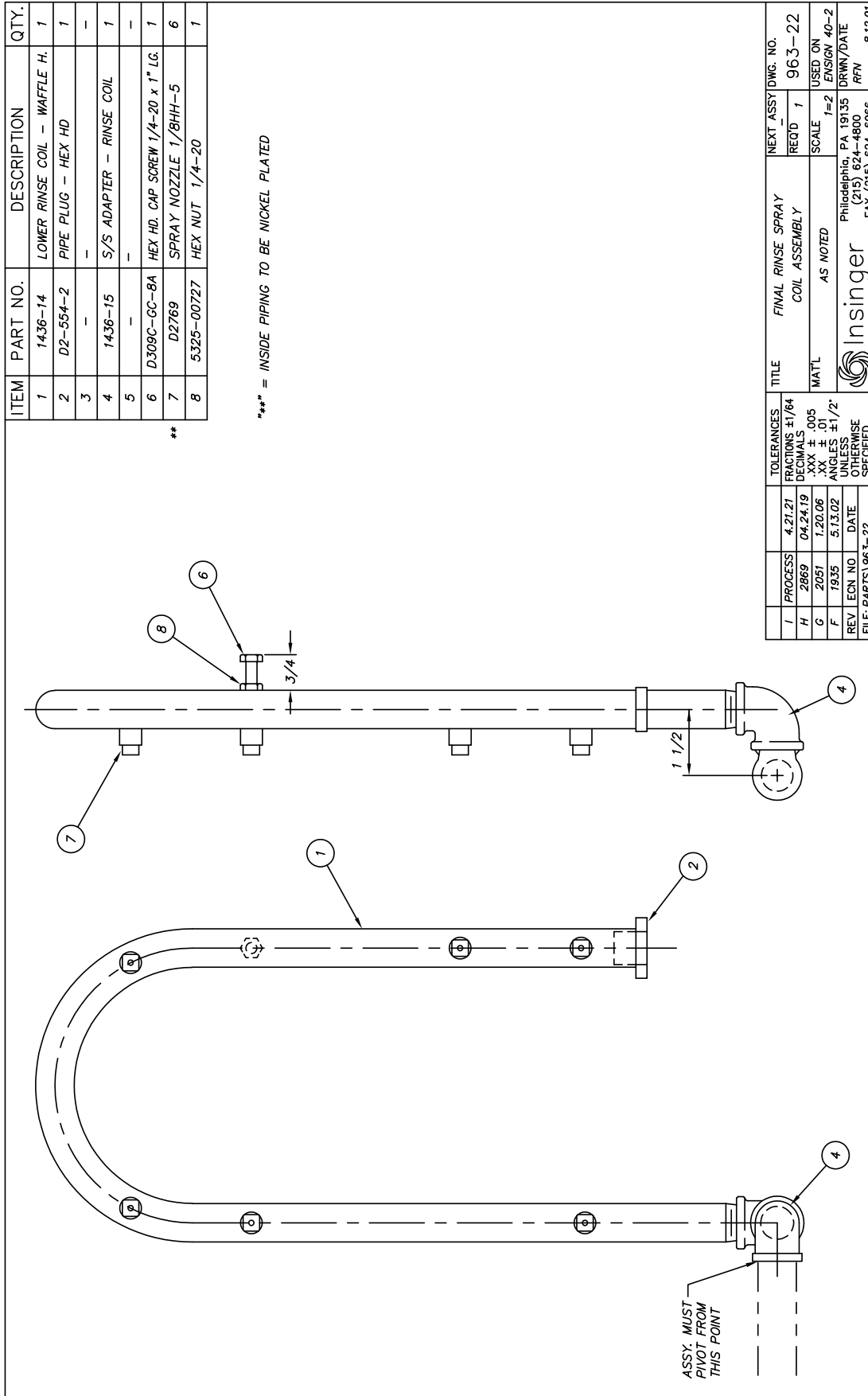

ITEM	PART NO.	SIZE	DESCRIPTION	QTY.
1	DES-37	-	PROXIMITY SWITCH & MAGNET	2
2	SK4089	A	MAGNET ENCLOSURE	2
3	5320-00657	-	WELDSTUD #6-32 X 3/8 LG	12
4	5325-00556	-	LOCKNUT #6-32	12
5	199-92	B	INNER COVER	1
6	199-93	B	OUTER COVER	1
7	#56	A	BUSHING (#963-49)	2
8	#28	A	SPACER WASHER (#963-50)	4
9	5330-00538	-	FLATWASHER 3/8	2
10	D309C-1C-11A	-	HHCS 3/8-16 UNC X 1 3/8 (FRONT)	1
11	5310-01643	-	HHCS 3/8-16 UNC X 2 LG (REAR)	1
12	5325-00522	-	HHCS 3/8-16 UNC X 3/4 LG	4
13	963-55A	A	ACORN NUT 3/8-16 UNC	6
14	D309C-DC-6B	-	RUBBER BUMPER (DO NOT USE E28)	2
15	199-87A	A	RHMS #6-32 X 3/4 LG	2
16	6320-00458	A	COVER BRACKET, FRONT	1
17	----	----	GENERAL PURPOSE HANDLE	2
18	199-87B	A	COVER BRACKET, REAR	1
19	963-55B	A	RUBBER BUMPER, LARGE	4
20	7500-02406	-	RUBBER DOOR SEAL (CUT 19 5/8")	1
21	5330-02495	-	NEOPRENE SEALING WASHER .1710 X .6900 X .06THK	4
22	5330-00548	-	#10 LARGE O.D. FLAT WASHER S/S	4
23	5305-02496	-	PAN HEAD SCREW S/S #10-24 X 1/2 LG	4
24	5330-00726	-	#10 LOCK WASHER S/S	4
25	SM-366	-	DAB OF LOCTITE 242 BLUE	DAB

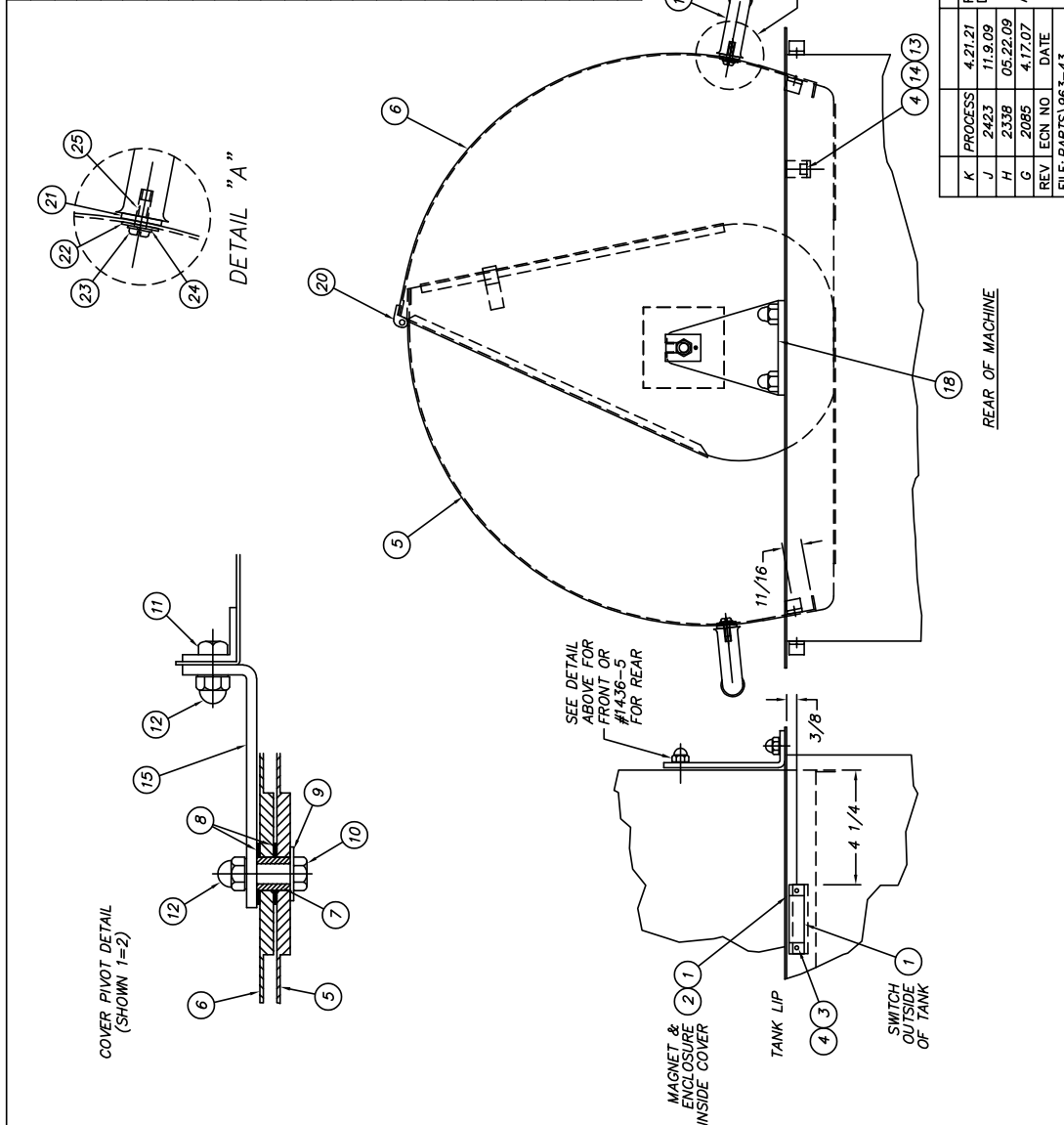

TOLERANCES		TITLE		NEXT ASSY DWG. NO.	
K	PROCESS	4.21.21	FRACTIONS ±1/64	DOOR INTERLOCK	963-43
J	2423	11.9.09	DECIMALS	SWITCH & ASSEMBLY	REQ'D/NOTED
H	2538	05.22.09	.XXX ± .01	NOTED	SCALE
G	2085	4.17.07	ANGLES ±1/2°	UNLESS OTHERWISE SPECIFIED	USED ON
REV	LECN NO	DATE	FILE: PARTS\963-43	ENGIN	1=4
				DRWN/DATE	PC
				FAX (215) 624-6966	9.2.93

Insinger
Machine Company

Philadelphia, PA 19135
(215) 624-4800

ITEM	PART NO.	DESCRIPTION	QTY.
37	D319A-E3-E2	90° UNION ELBOW 3/4 C X 3/4 MIPS	1
38	D318F-E1-E1	UNION 3/4 FIPS	1

NOTES:
 **= INSIDE PIPING TO BE NICKEL PLATED

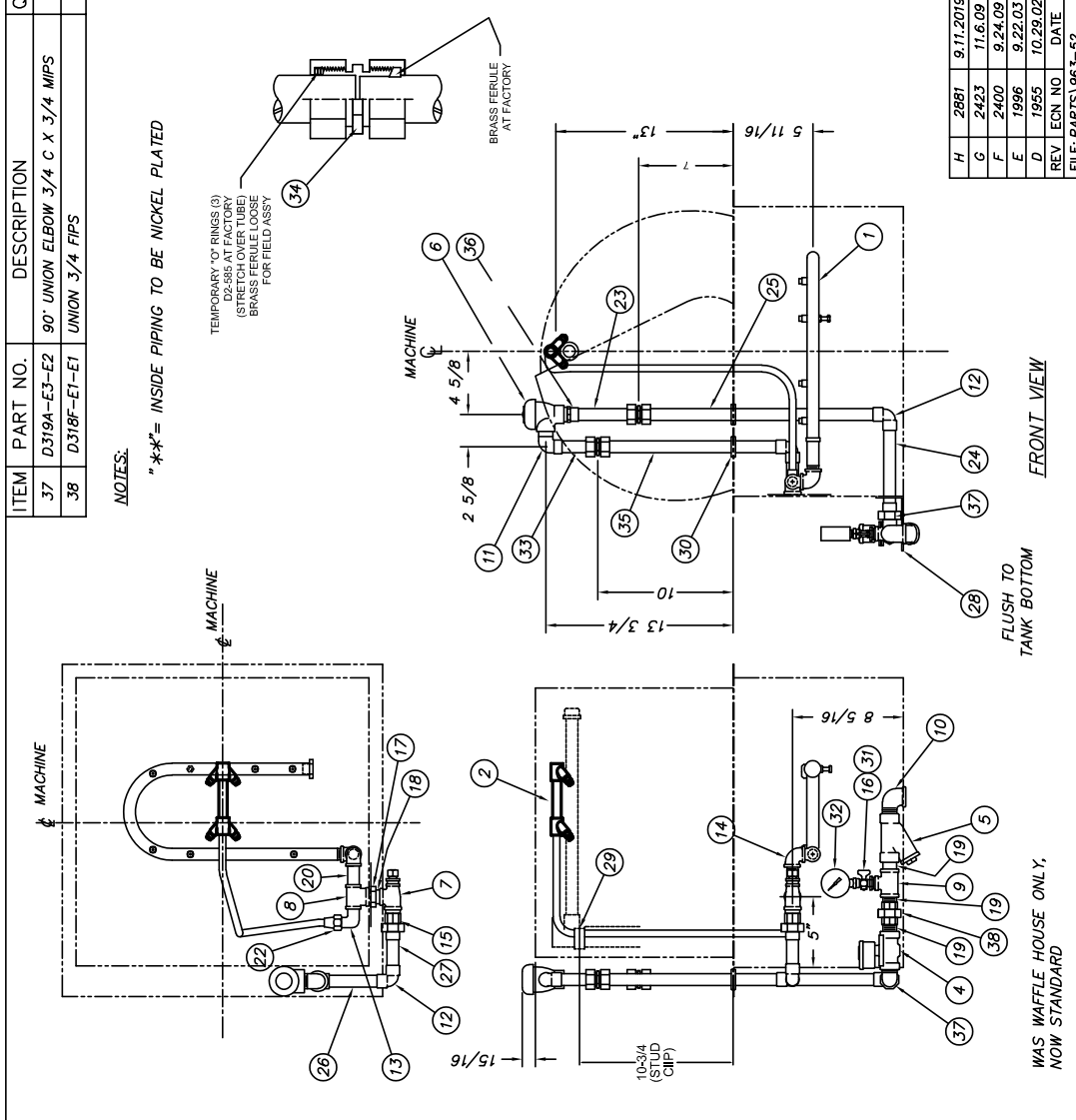

ITEM	PART NO.	DESCRIPTION	QTY.
1	963-22	SPRAY COIL ASSEMBLY	1
2	7400-01822	FINAL RINSE ASSEMBLY, TOP, 40-2	1
4	4905-01830	Solvent/Water, 3/4" NPT 24VAC 50/60HZ	1
5	D2482	"Y" STRAINER 3/4 IPS	1
6	D2243	VACUUM BREAKER 3/4 IPS	1
7	D320F-E1D1E1	TEE 3/4 FIPS x 1/2 FIPS x 3/4 FIPS	1
8	D320J-D1D1E1	TEE 1/2 FIPS x 1/2 FIPS x 3/4 FIPS	1
9	D320F-E1E1D1	TEE 3/4 FIPS x 3/4 FIPS x 1/2 FIPS	1
10	D316F-E1-E2	90° ST ELL, 3/4 F X 3/4 M	1
11	D316A-E3-E2	90° ST ELL, 3/4 C x 3/4 MIPS	1
12	D316A-E3-E3	90° ELBOW 3/4 C	3
13	D316F-U6-D2	45° FLARE COMP TUBE X 1/2 MIPS 90° EL	1
14	1436-15	TWIN ELBOW ADAPTER	REF
15	D318A-E3-E2	UNION 3/4 C x 3/4 MIPS	1
16	4825-01050	HEX RED. 1/2 MIPS x 1/4 FIPS	1
17	D326F-E1	LOCK NUT 3/4 IPS	1
18	D314F-EA-14	NIPPLE 3/4 IPS x 1 3/4 LG. ALL THD.	1
19	D314F-EC-00	CLOSE NIPPLE 3/4 IPS	3
20	4805-01389	NIPPLE S/S 1/2 IPS x 2" LG.	1
22	D351F-U6	45° FLARE COMP TUBE NUT 5/8	REF
23	D207A-B6-20	COPPER TUBE 3/4 CTS x 5" LG.	1
24	D207A-B6-28	COPPER TUBE 3/4 CTS x 7 LG.	1
25	D207A-B6-71	COPPER TUBE 3/4 CTS x 17 3/4 LG.	1
26	D207A-B6-16	COPPER TUBE 3/4 CTS x 4" LG.	1
27	D207A-B6-9	COPPER TUBE 3/4 CTS x 2 1/4 LG.	1
28	963-24	BRACKET	1
29	963-51	UPPER RINSE TUBE CLIP	1
30	D2062	GROMMET	2
31	D2497	PETCOCK	1
32	SK1433	PRESSURE GAUGE	1
33	D207A-B6-12	COPPER TUBE 3/4 CTS x 3" LG	1
34	D317F-E5-E5	ADAPTER 3/4C COMPRESSION, NO FLARE	2
35	D207A-B6-55	COPPER TUBE 3/4 CTS x 13 5/8 LG	1
36	D317A-E3-E2	3/4 C x 3/4 MIPS ADAPTER	1

TOLERANCES		NEXT ASSY DWG. NO.	
H	2881	9.17.2019	963-52
G	2423	11.6.09	REF 1
F	2400	9.24.09	SCALE
E	1996	.005	USED ON
D	1955	9.22.03	ENGIN 40-2
REV	ECN NO.	DATE	DRWN/DATE
			GP

TITLE		FINAL RINSE PIPING ASSY	
MATERIAL		AS NOTED	
SCALE		1=8	
MATERIAL		USED ON	
MATERIAL		ENGIN 40-2	

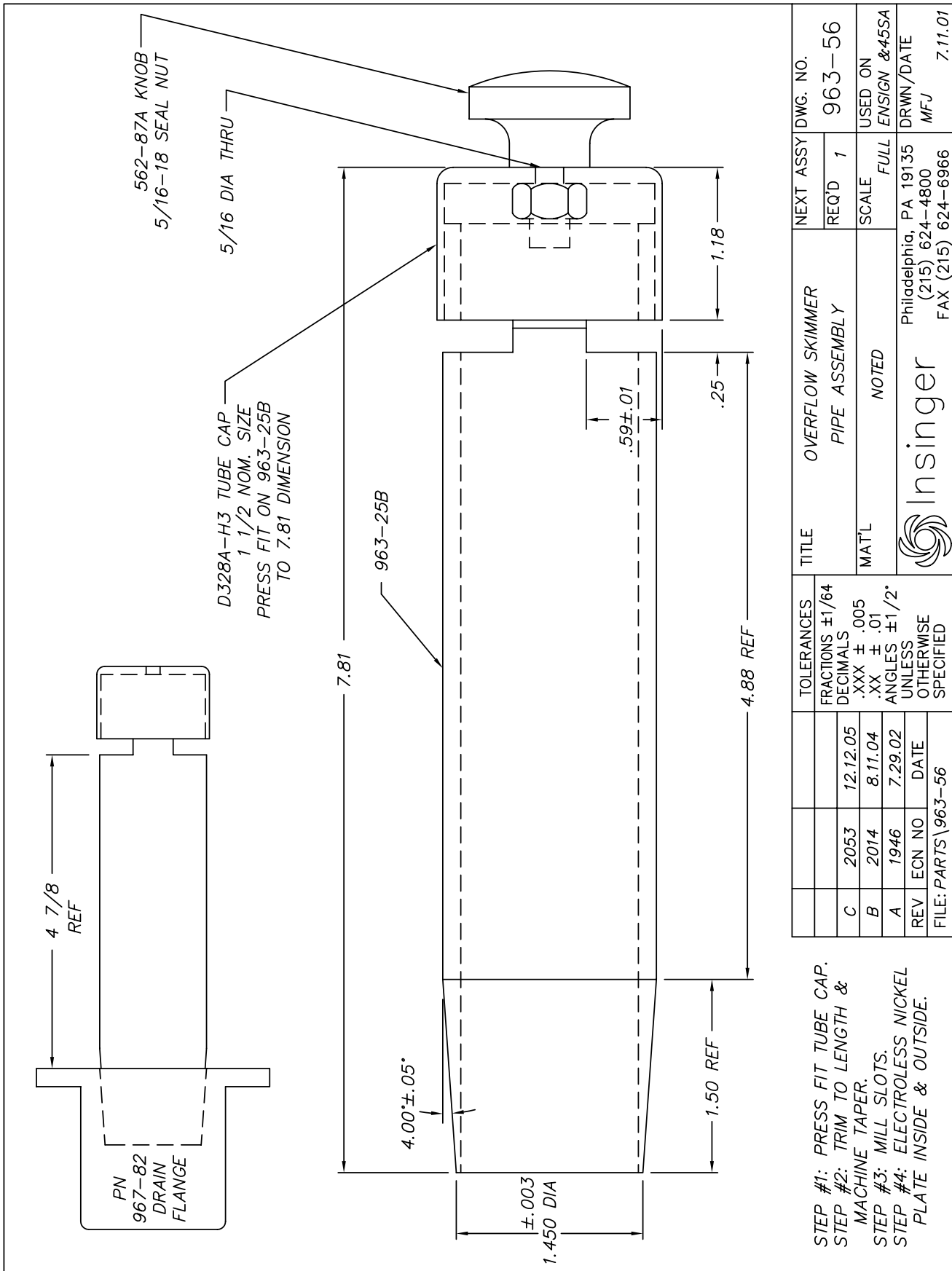

Insinger
 Philadelphia, PA 19135
 (215) 624-4800
 FAX (215) 624-6966
 5.21.01

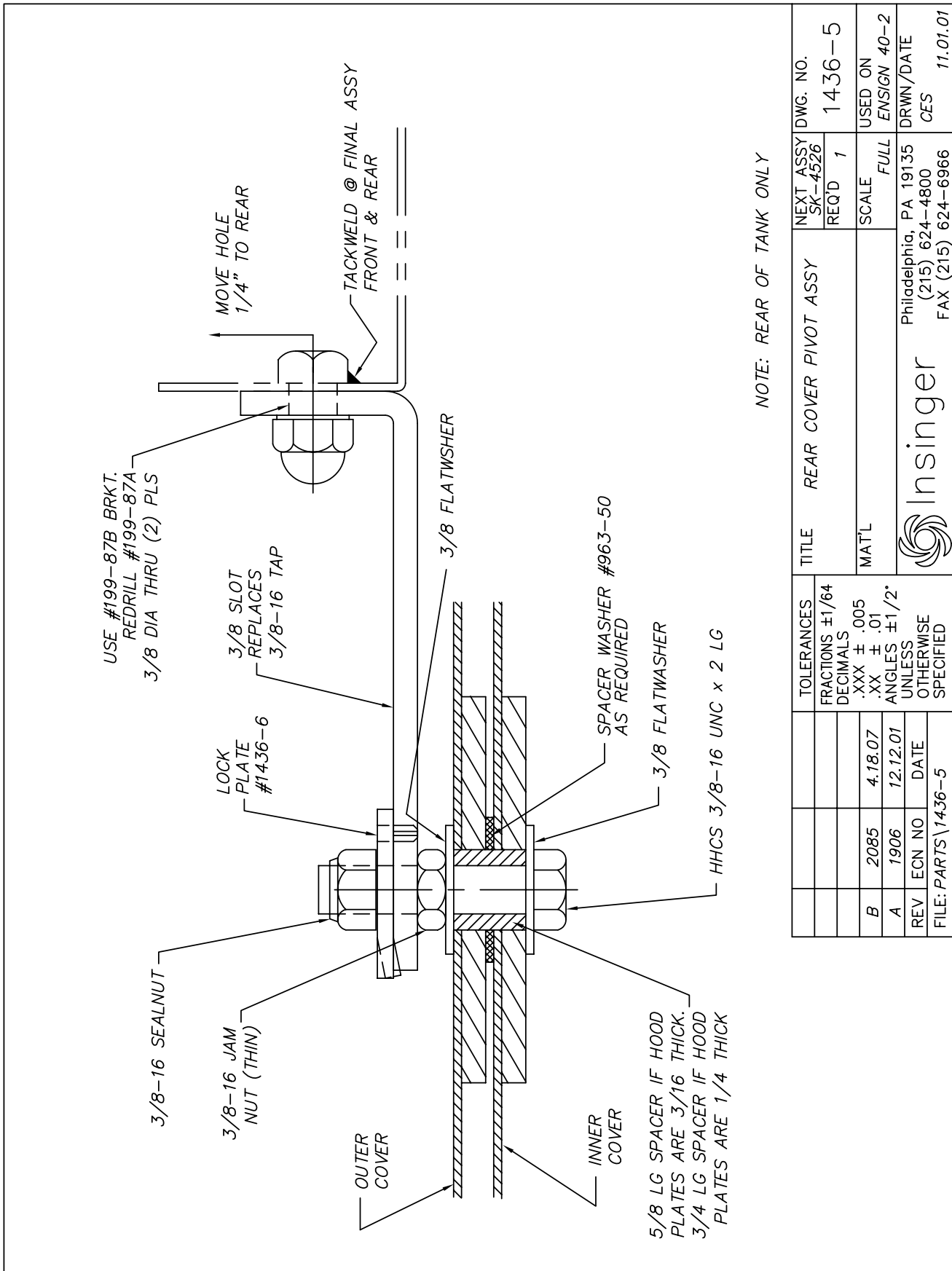

TOLERANCES		TITLE	NEXT ASSY	DWG. NO.
FRACTIONS ±1/64	DECIMALS			
.XXX ± .005	.XX ± .01	MAT'L	SCALE	USED ON
ANGLES ±1/2°	UNLESS OTHERWISE SPECIFIED	NOTED	FULL	ENSGN &45SA
REV	ECN NO	DATE	Philadelphis, PA 19135	
A	1946	7.29.02	(215) 624-4800	
B	2014	8.11.04	FAX (215) 624-6966	
C	2053	12.12.05	Insinger	
FILE: PARTS\963-56		DRWN/DATE		
		MFJ 7.11.01		

STEP #1: PRESS FIT TUBE CAP.
 STEP #2: TRIM TO LENGTH & MACHINE TAPER.
 STEP #3: MILL SLOTS.
 STEP #4: ELECTROLESS NICKEL PLATE INSIDE & OUTSIDE.



TOLERANCES	TITLE	NEXT ASSY	DWG. NO.
FRACTIONS ±1/64	REAR COVER PIVOT ASSY	SK-4526	1436-5
DECIMALS	MAT'L	REQD 1	SCALE
.XXX ± .005			FULL
.XX ± .01			USED ON
ANGLES ±1/2°			ENSGN 40-2
UNLESS OTHERWISE SPECIFIED			DRWN/DATE
	 Insinger		CES
	Philadelphia, PA 19135		11.01.01
	(215) 624-4800		
	FAX (215) 624-6966		
	FILE: PARTS\1436-5		

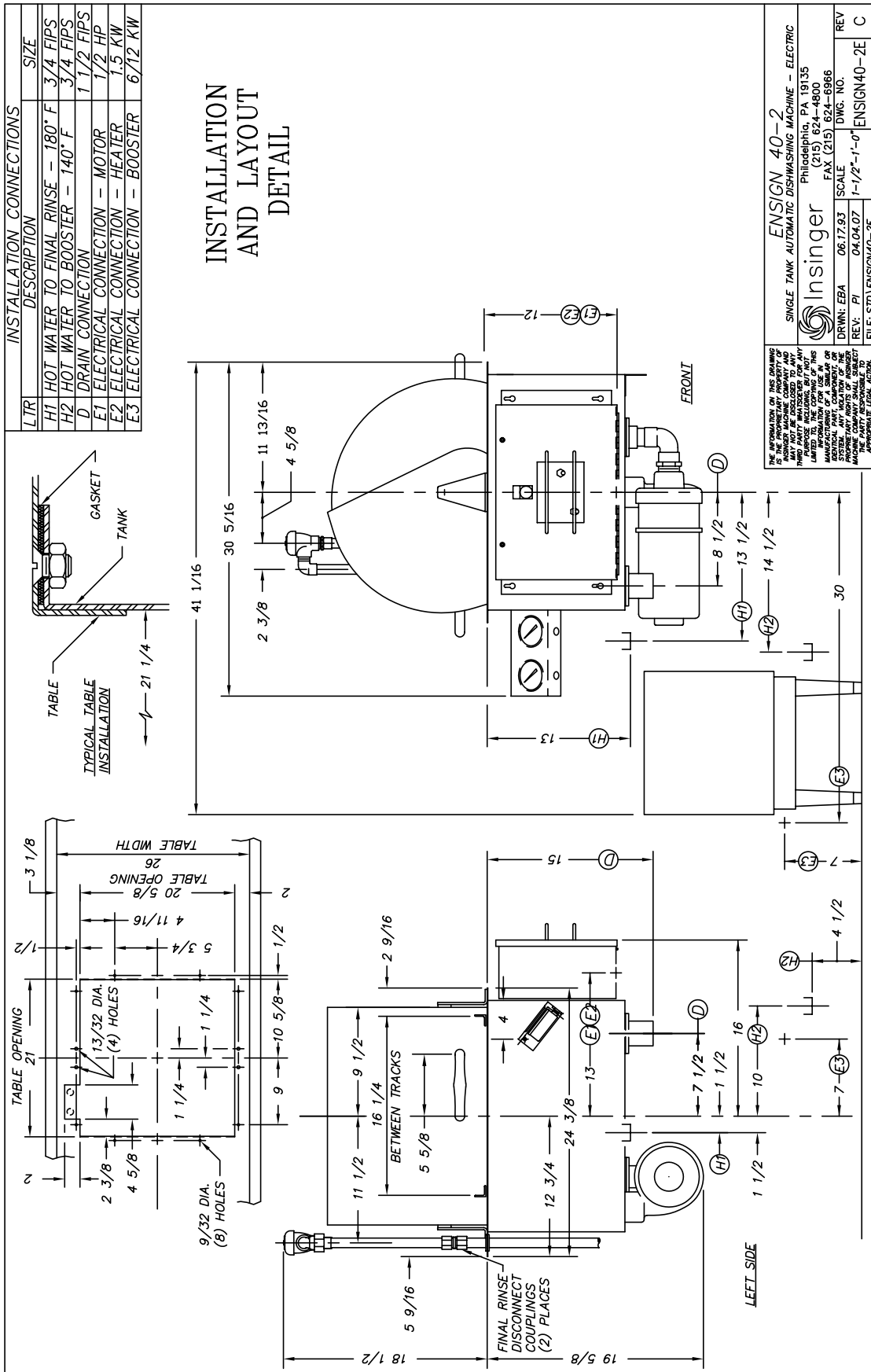

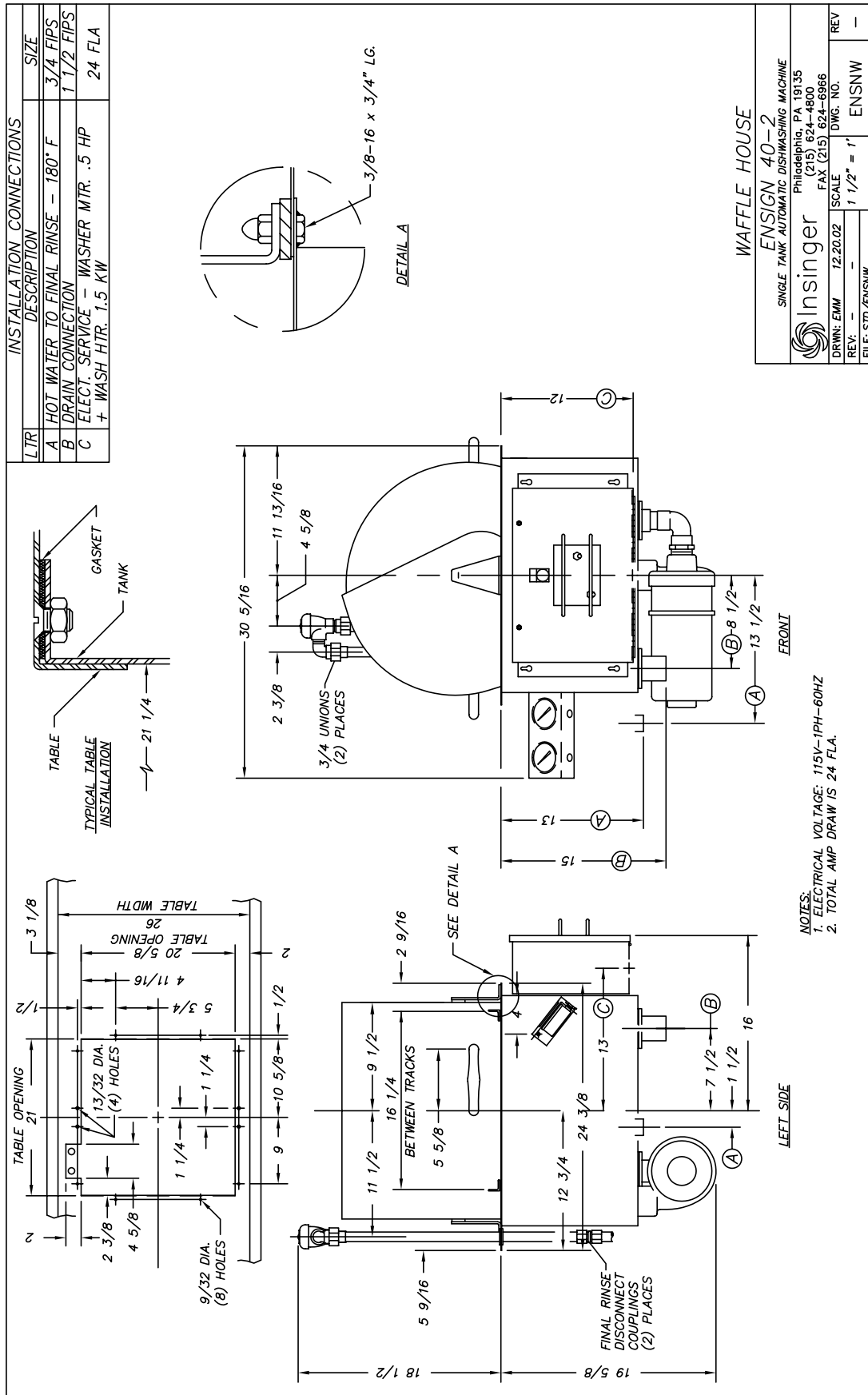

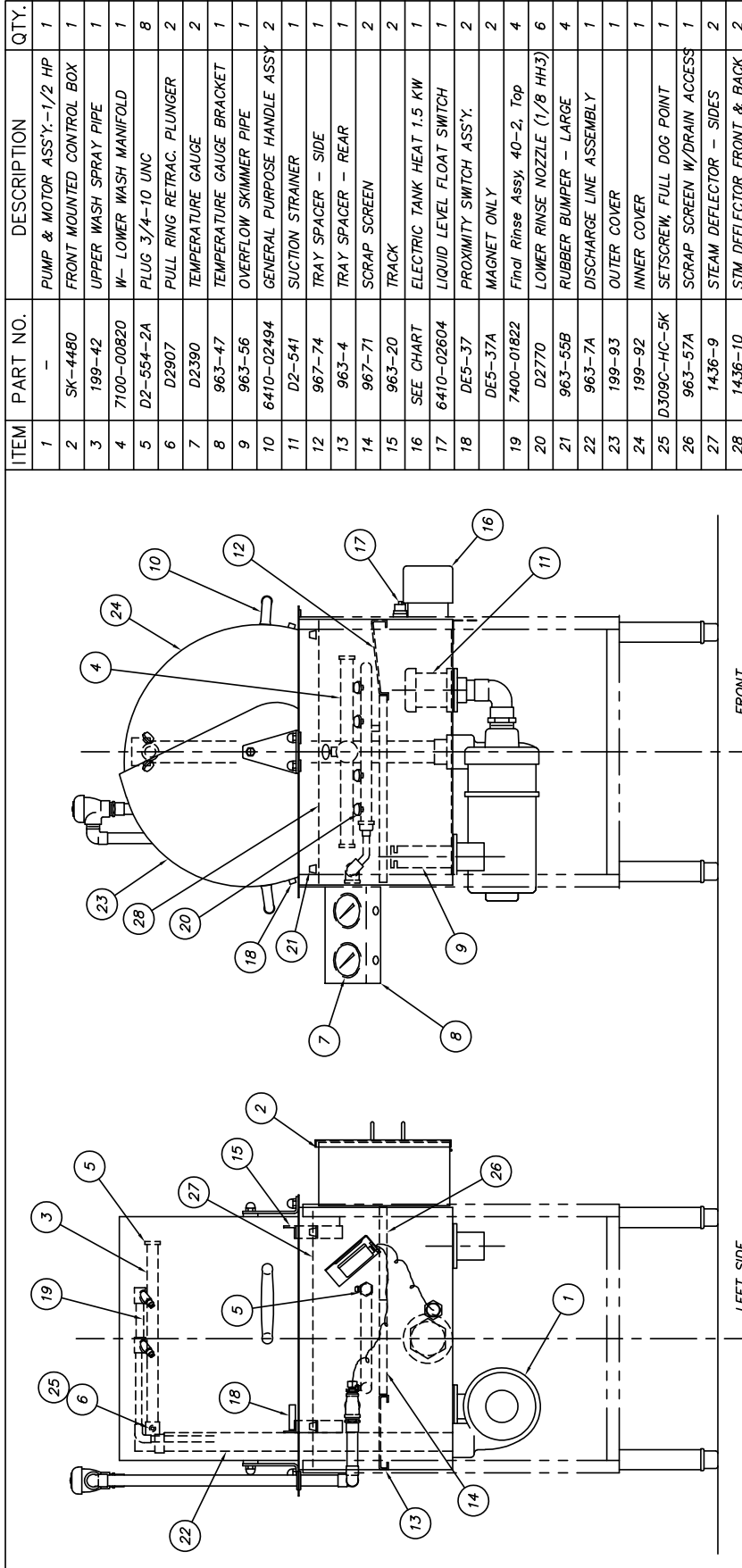

COUNTER TOP MODELS DO NOT HAVE A STAND OR FRONT PANEL.

ITEM #16	ELECTRIC HEATER
4440-01475	208 VAC/1 PH
DE13-SB23	208 VAC/3 PH
DE13-SB41	220-240 VAC/1 PH
DE13-SB43	220-240 VAC/3 PH
DE13-SB53	380 VAC/3 PH
DE13-SB73	440-480 VAC/3 PH
DE13-SD21	110-115 VAC/1 PH

SKW 208 DERATED

ITEM	PART NO.	DESCRIPTION	QTY.
1	-	PUMP & MOTOR ASS'Y - 1/2 HP	1
2	SK-4480	FRONT MOUNTED CONTROL BOX	1
3	199-42	UPPER WASH SPRAY PIPE	1
4	7100-00820	W- LOWER WASH MANIFOLD	1
5	D2-554-2A	PLUG 3/4-10 UNC	8
6	D2907	PULL RING RETRAC. PLUNGER	2
7	D2390	TEMPERATURE GAUGE	2
8	963-47	TEMPERATURE GAUGE BRACKET	1
9	963-56	OVERFLOW SKIMMER PIPE	1
10	6410-02494	GENERAL PURPOSE HANDLE ASSY	2
11	D2-541	SUCTION STRAINER	1
12	967-74	TRAY SPACER - SIDE	1
13	963-4	TRAY SPACER - REAR	1
14	967-71	SCRAP SCREEN	2
15	963-20	TRACK	2
16	SEE CHART	ELECTRIC TANK HEAT 1.5 KW	1
17	6410-02604	LIQUID LEVEL FLOAT SWITCH	1
18	DE5-37	PROXIMITY SWITCH ASS'Y.	2
	DE5-37A	MAGNET ONLY	2
19	7400-01822	Final Rinse Assy. 40-2, Top	4
20	D2770	LOWER RINSE NOZZLE (1/8 HH3)	6
21	963-55B	RUBBER BUMPER - LARGE	4
22	963-7A	DISCHARGE LINE ASSEMBLY	1
23	199-93	OUTER COVER	1
24	199-92	INNER COVER	1
25	D309C-HC-5K	SETSCREW, FULL DOG POINT	1
26	963-57A	SCRAP SCREEN W/DRAIN ACCESS	1
27	1436-9	STEAM DEFLECTOR - SIDES	2
28	1436-10	STM DEFLECTOR FRONT & BACK	2

TOLERANCES		TITLE		NEXT ASSY DWG. NO.	
FRACTIONS	±1/64	PARTS LIST	RECD	SK-2342	
DECIMALS		ENGIN 40-2			
.XXX ± .005					
.XXX ± .01					
ANGLES ± 1/2°					
UNLESS OTHERWISE SPECIFIED					
REV	ECN NO	DATE	MATL	SCALE	USED ON
D	7938	6/10/02		1=8	40-2
G	2891	12/11/19			
E	2423	11/9/09			
F	2891	12/11/19			
G	PROCESS	4.28.21			

Insinger

Philadelphia, PA 19135
 (215) 624-4800
 FAX (215) 624-6866
 CES 3.23.01

ITEM	PART NO.	DESCRIPTION	QTY.
1		MOTOR 1 H.P.	1
2	D431	ADAPTER	1
3	D436	IMPELLER 3 7/8"	1
4	D434	CASING	1
5	D2-532	"O" RING	1
6	D2-533	FLINGER	1
7	D2-534	SEAL ASSEMBLY	1
8	D329-5	DRAIN PETCOCK 1/4 IPS	1
9	D3-808	IMPELLER RETAINING NUT	1

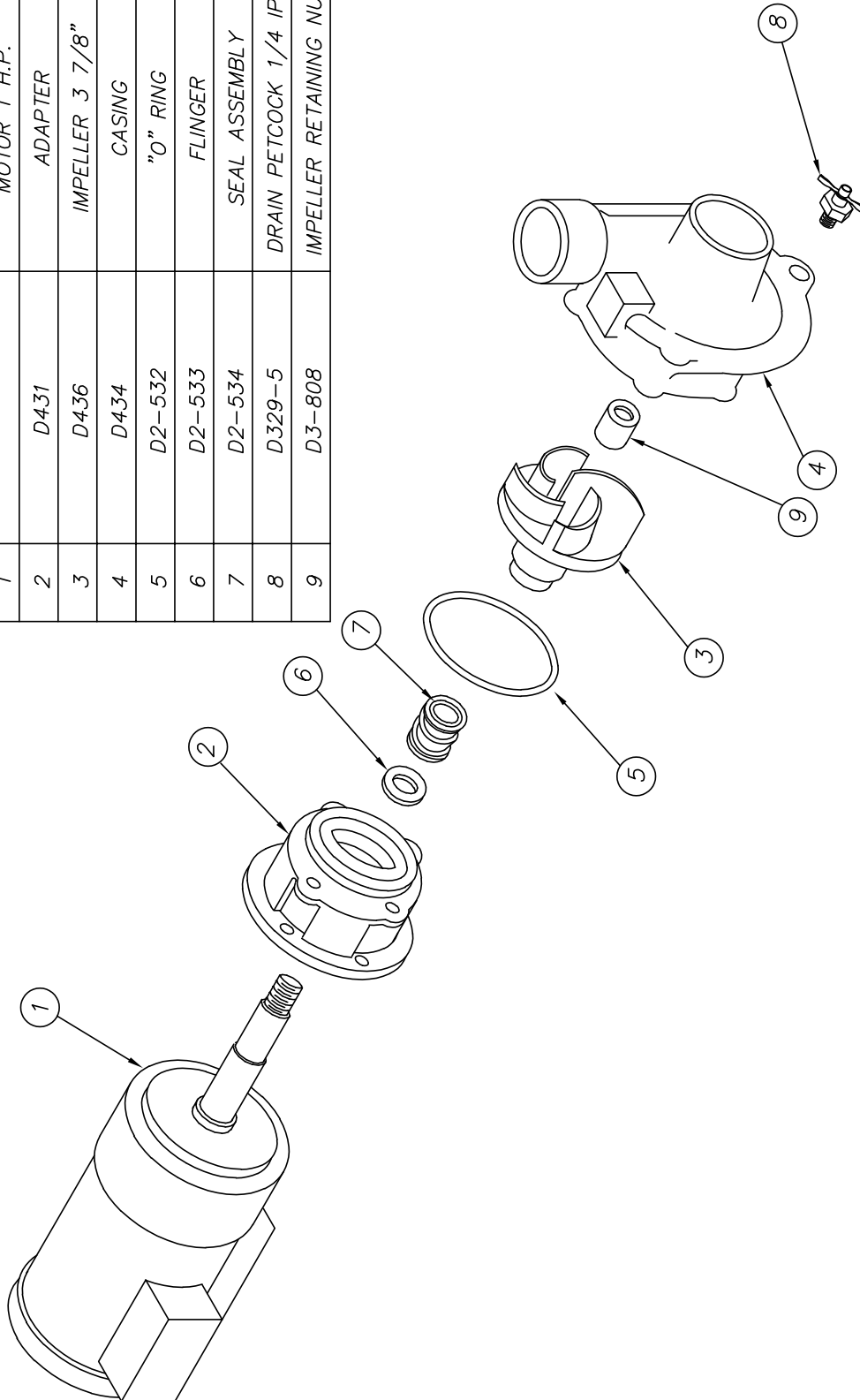

TOLERANCES		TITLE	PARTS LIST	NEXT ASSY	DWG. NO.
D	PROCESS				
C	2007	3.25.04	MAT'L	SCALE	USED ON
B	1761	5.5.00			VARIOUS
A	1005	4.26.94			
REV	ECN NO	DATE	Philadelphia, PA 19135		
			(215) 624-4800		
			FAX (215) 624-6966		
FILE: SKETCHA \ SK-2462			DRWN/DATE		
			MAM 11.11.93		

ITEM	DESCRIPTION	PART NO.	QTY	ITEM	DESCRIPTION	PART NO.	QTY
18	TIMER (LIQUID LEVEL)	5960-02286	1	1	COMPONENT MOUNTING PLATE	SK-4481	1
19	OVERLOAD BASE	6405-02316	1	2	TRANSFORMER (100 VA, 24 VAC) ALL VOLTAGES EXCEPT 120 V	5950-01164	1
20	TERMINAL BLOCK	5940-00655	9		120 V	DE6-14	
21	TERMINAL BLOCK END	5940-00654	1	3	FUSE BLOCK (100 VA XFMR)	DE9-185	1
22	GROUNDING STUD, 1/4-20	5320-00542	1	4	FUSE (100 VA TRANSFORMER PRIMARY)	DE9-166	2
23	LOCKWASHER, 1/4	5330-00390	1		440 - 480 V FNQ-R-75	DE9-166	
24	HEX NUT, 1/4-20	5325-00727	1		380 V FNQ-R-75	DE9-166	
					220 - 230 V FNQ-R-1.4	DE9-168	
					208 V FNQ-R-1.5	DE9-200	
					115 V FNQ-R-2.8	DE9-200	
				5	OVERLOAD RELAY (1/2 HP PUMP)	DE2-50	1
					460/3/60 1-1.7 A	DE2-50	
					380/3/60 1-1.7 A	DE2-50	
					230/3/60 1.6-2.5 A	DE2-52	
					220/3/60 1.6-2.5 A	DE2-52	
					220/1/60 4-6 A	5945-01116	
					208/3/60 1.6-2.5 A	DE2-52	
					115/1/60 7-10 A	DE2-56	
				6	CONTACTOR (PUMP) SP4	5945-02282	1
				7	CONTACTOR (ELECT TANK HEAT) SP4	5945-02282	1
				8	TIME DELAY BOARD (WASH & RINSE)	DE7-27	2
				9	RELAY BASE	5945-01118	AR
				10	RELAY	5945-01117	AR
				11	RELAY HOLD DOWN SPRING	5345-02313	AR
				12	DIN RAIL (35 mm)	4797-00460	1
				13	DIN RAIL (15 mm)	4797-00708	1
				14	TERMINAL SECTION	5940-00704	16
				15	TERMINAL END COVER PLATE	5940-00705	1
				16	TERMINAL END CLAMP	5940-00706	2
				17	TEMPERATURE CONTROL BOARD	5955-02284	1

ITEM	DESCRIPTION	PART NO.	QTY
18	TIMER (LIQUID LEVEL)	5960-02286	1
19	OVERLOAD BASE	6405-02316	1
20	TERMINAL BLOCK	5940-00655	9
21	TERMINAL BLOCK END	5940-00654	1
22	GROUNDING STUD, 1/4-20	5320-00542	1
23	LOCKWASHER, 1/4	5330-00390	1
24	HEX NUT, 1/4-20	5325-00727	1

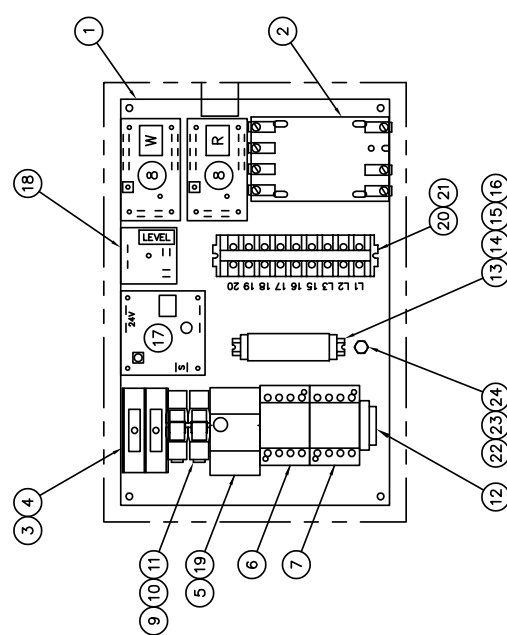

ITEM	DESCRIPTION	PART NO.	QTY
	ELECTRIC IMMERSION HEATER (1.5 KW)	DE13-SB73	1
	440-480 V, 3 PH	DE13-SB53	
	380 V, 3 PH	DE13-SB43	
	220-240 V, 3 PH	DE13-SB23	
	208V, 3PH	DE13-SB41	
	220-240 V, 1 PH	4440-01475	
	208V, 1 PH	DE13-SD21	
	110-120 V, 1 PH (5KW 208 DERATED)	5025-02318	1
	TEMPERATURE SENSOR		

NOT SHOWN

TITLE		ENSGN 40-2		SHEET 1 OF 2	
FRONT MOUNTED CONTROL PANEL LAYOUT		Philadelphia, PA 19135		DRWN/DATE	
Insinger		(215) 814-4800		MPJ	
F		4.28.21		5.11.01	
E		2564		FILE: SKETCH/ SK-4480	
D		2024		SCALE	
REV		ECN NO		DWG. NO.	
DATE		1/4		SK-4480	

ITEM	DESCRIPTION	PART NO.	QTY
25	PILOT LIGHT (AMBER)	DE9-109	1
26	CIRCUIT BREAKER (SA)	5925-02293	1
27	SWITCH (AUTO - MANUAL)	5930-00436	1
28	BOOT	DE9-13	2
29	SWITCH, DPDT (POWER ON)	5930-00436	1
30	PILOT LIGHT (RED)	DE9-107	1
31	PILOT LIGHT (WHITE)	DE9-108	1
32	CONTROL BOX	SK-4482	1
33	LEGEND DECAL	SK-4468	1
34	PUSHBUTTON ASSY, START	DE8-64	1
35	1/2" STRAIN RELIEF - 1/4" CABLE	EM187	1

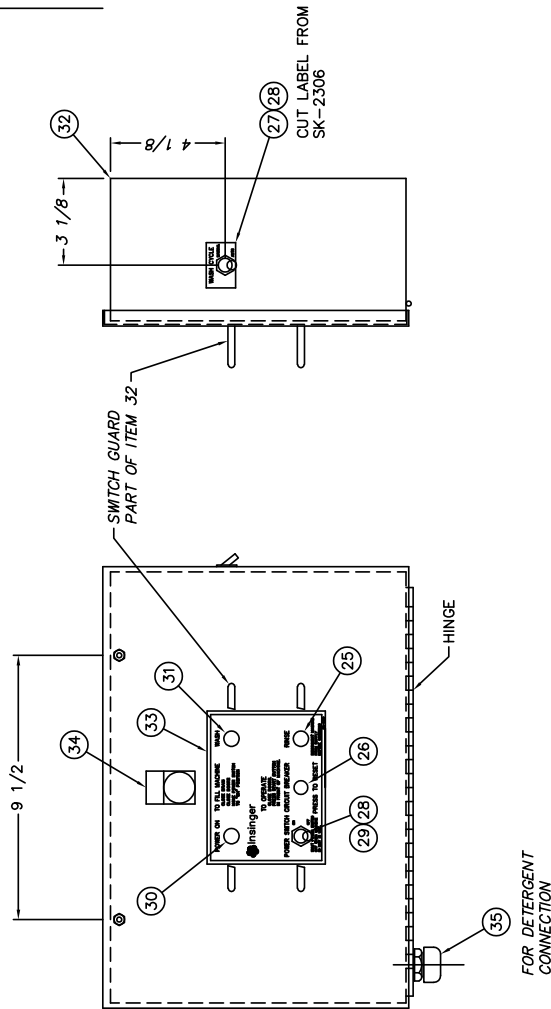

SHEET 2 OF 2

TITLE		ENGIN 40-2	
FRONT MOUNTED CONTROL PANEL LAYOUT			
 Insinger Philadelphia, PA 19135 DRWN/DATE (215) 624-4800 MFJ FAX (215) 624-6966 5.11.01			
F	PROCESS	4.28.21	FILE: SKETCH\SK-4480
E	2564	3.9.12	DWG. NO.
D	2024	12.1.04	SCALE
REV	ECN NO	DATE	1/4
			SK-4480

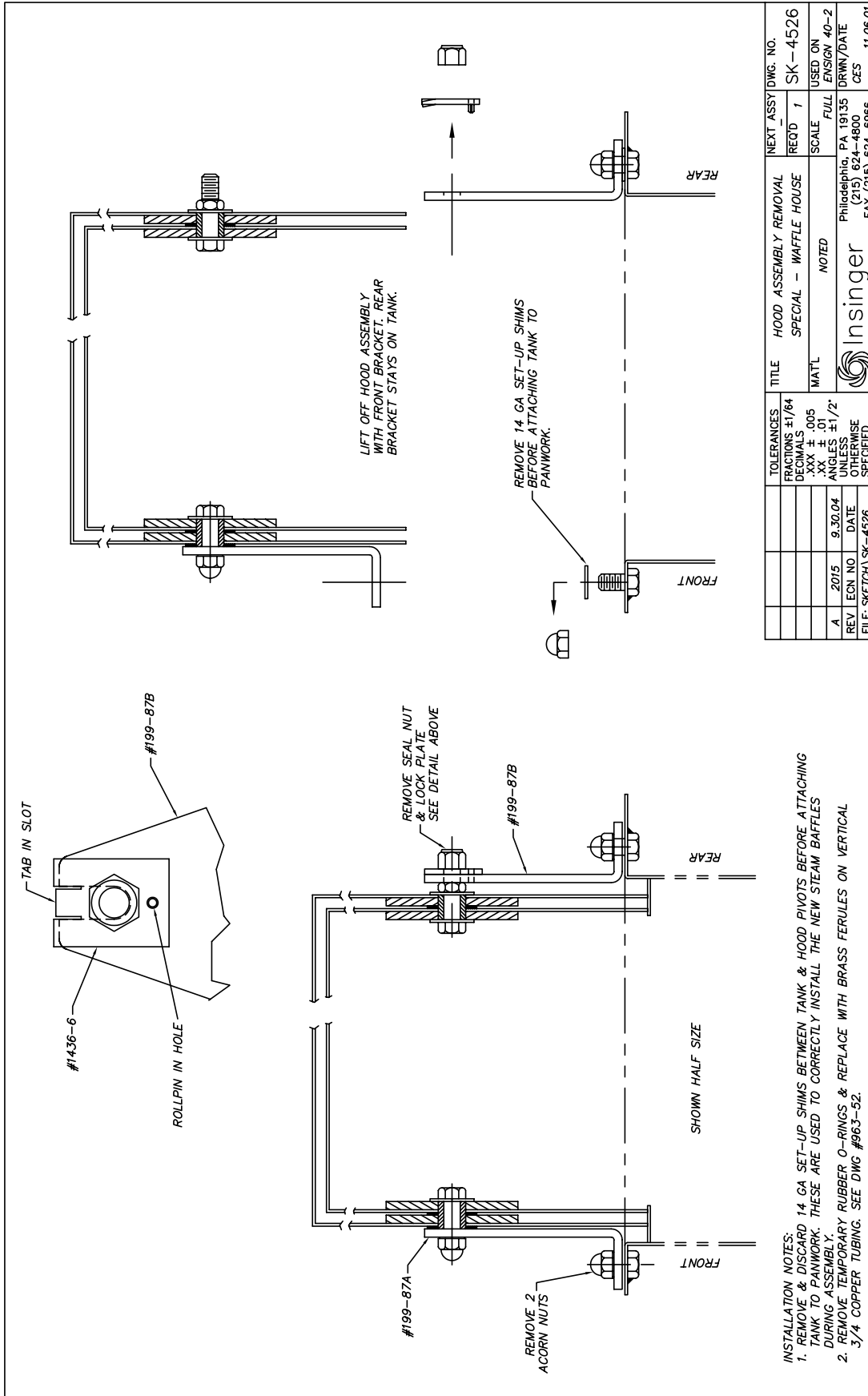

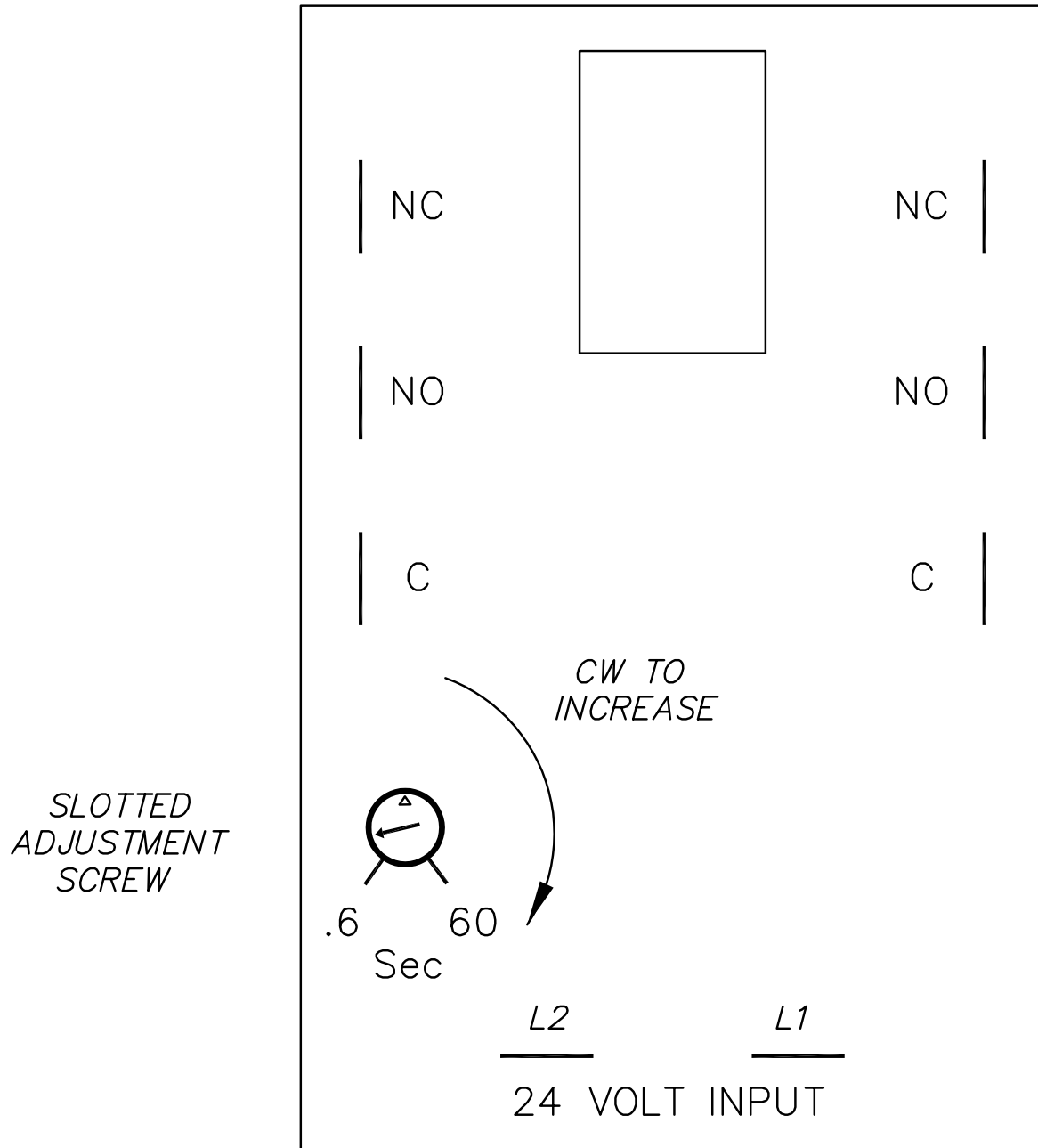

WASH & RINSE TIMER DE7-27

SKETCHA\SK-4708

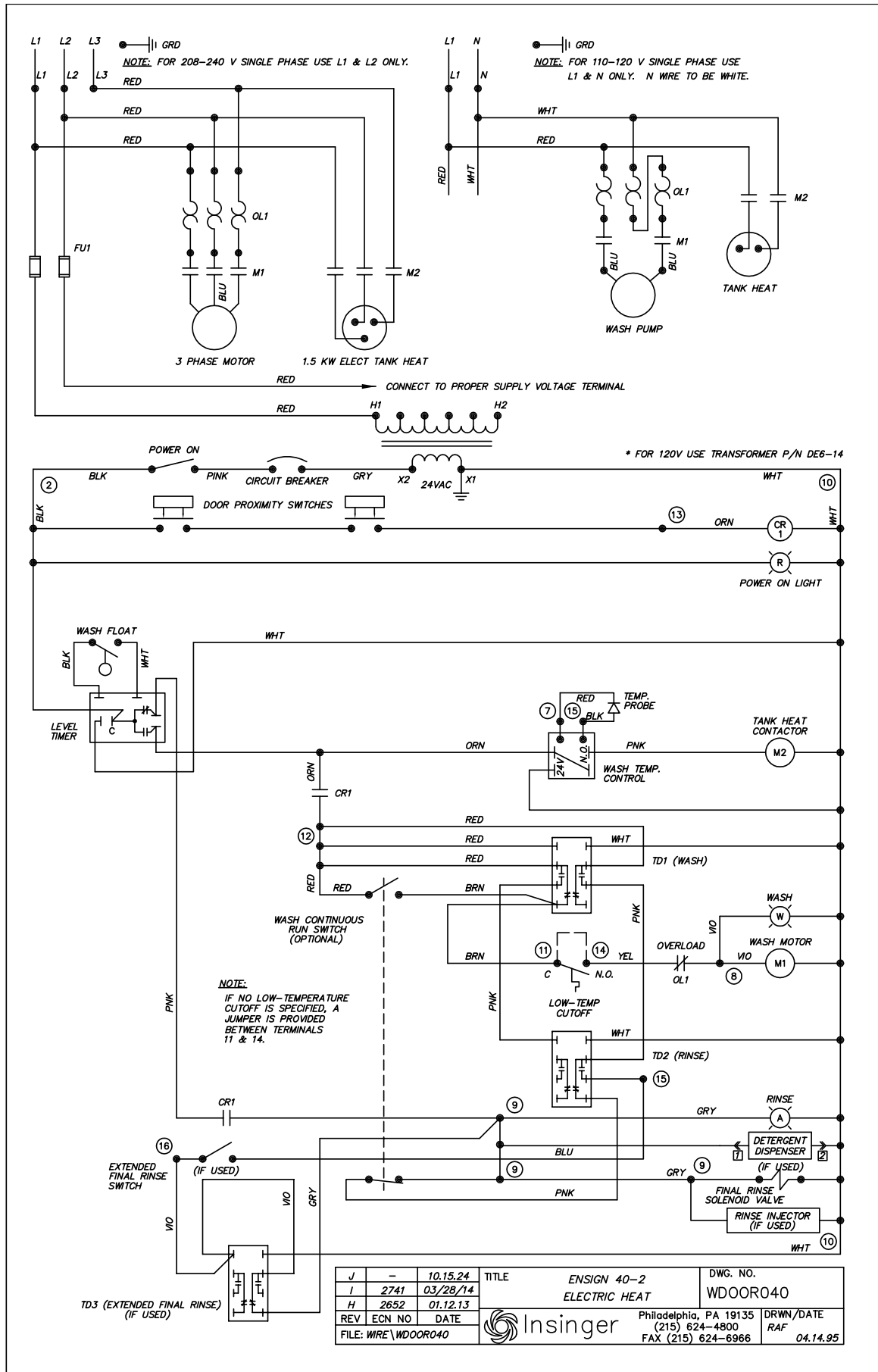

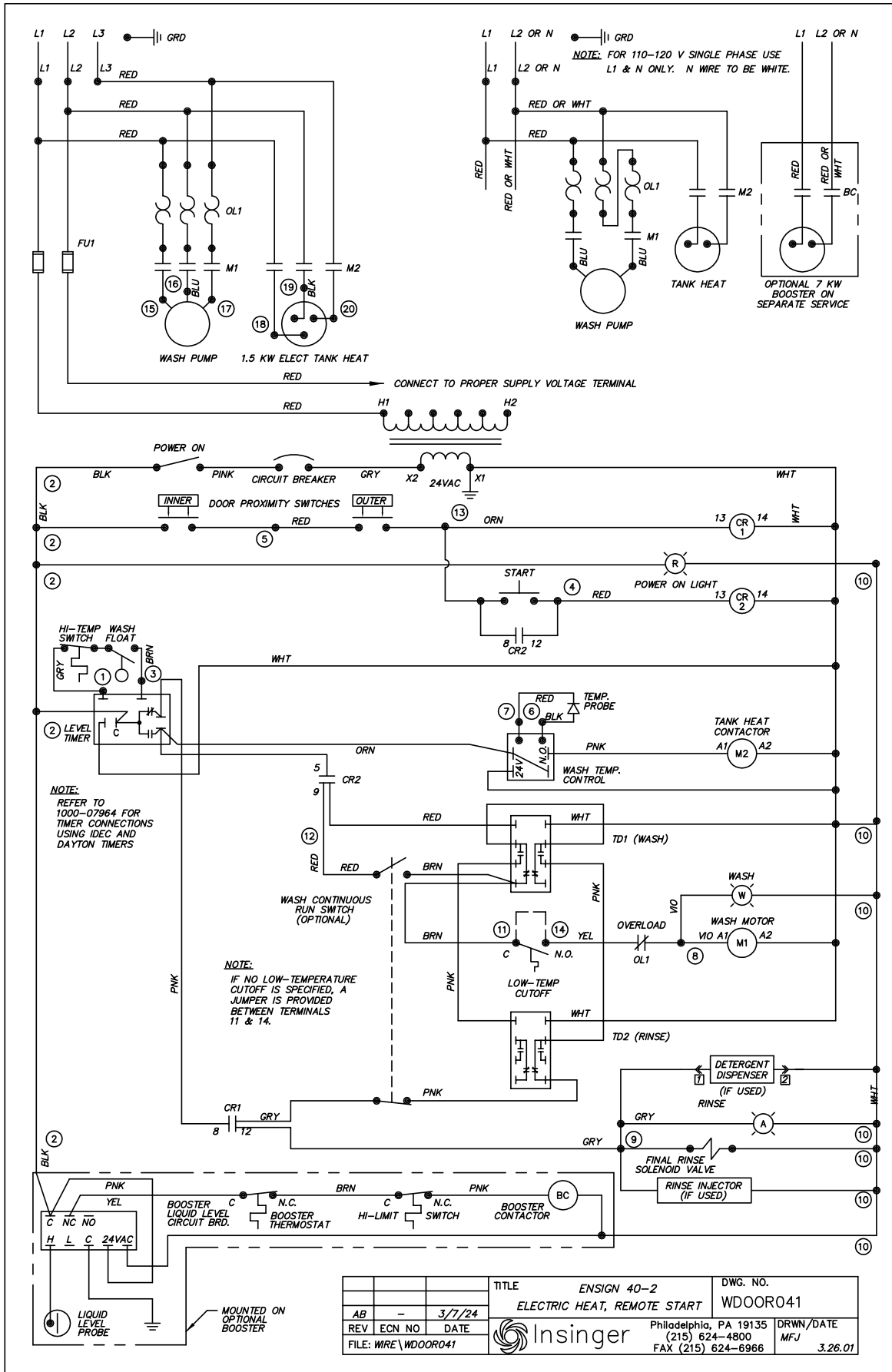

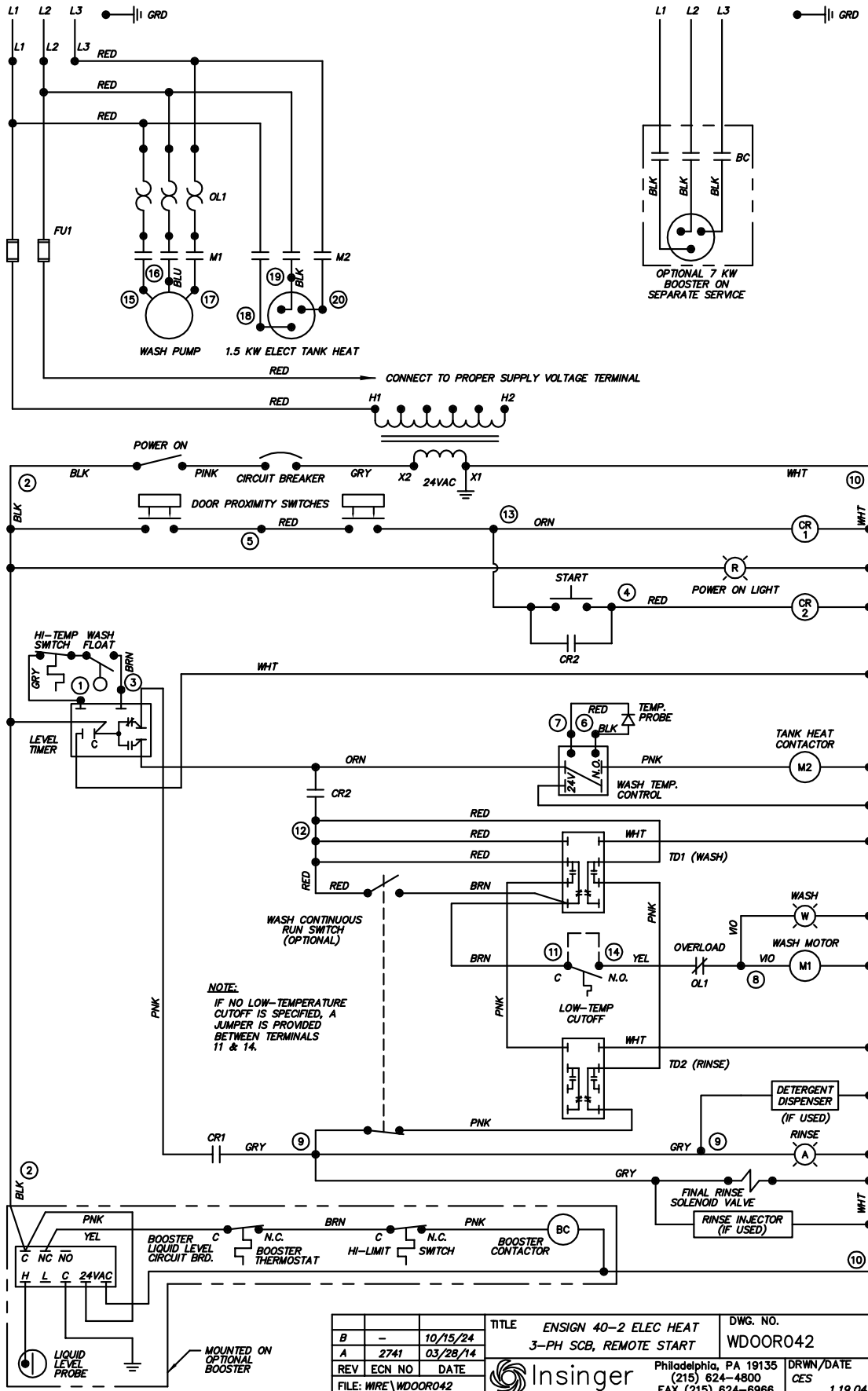

			TITLE		ENSGN 40-2 ELEC HEAT		DWG. NO.	
					3-PH SCB, REMOTE START		WDOOR042	
B	-	10/15/24	REV		ECN NO		DATE	
A	2741	03/28/14	REV		ECN NO		DATE	
FILE: WIRE\WDOOR042			Insinger		Philadelphia, PA 19135		DRWN/DATE	
					(215) 624-4800		CES	
					FAX (215) 624-6966		1.19.04	

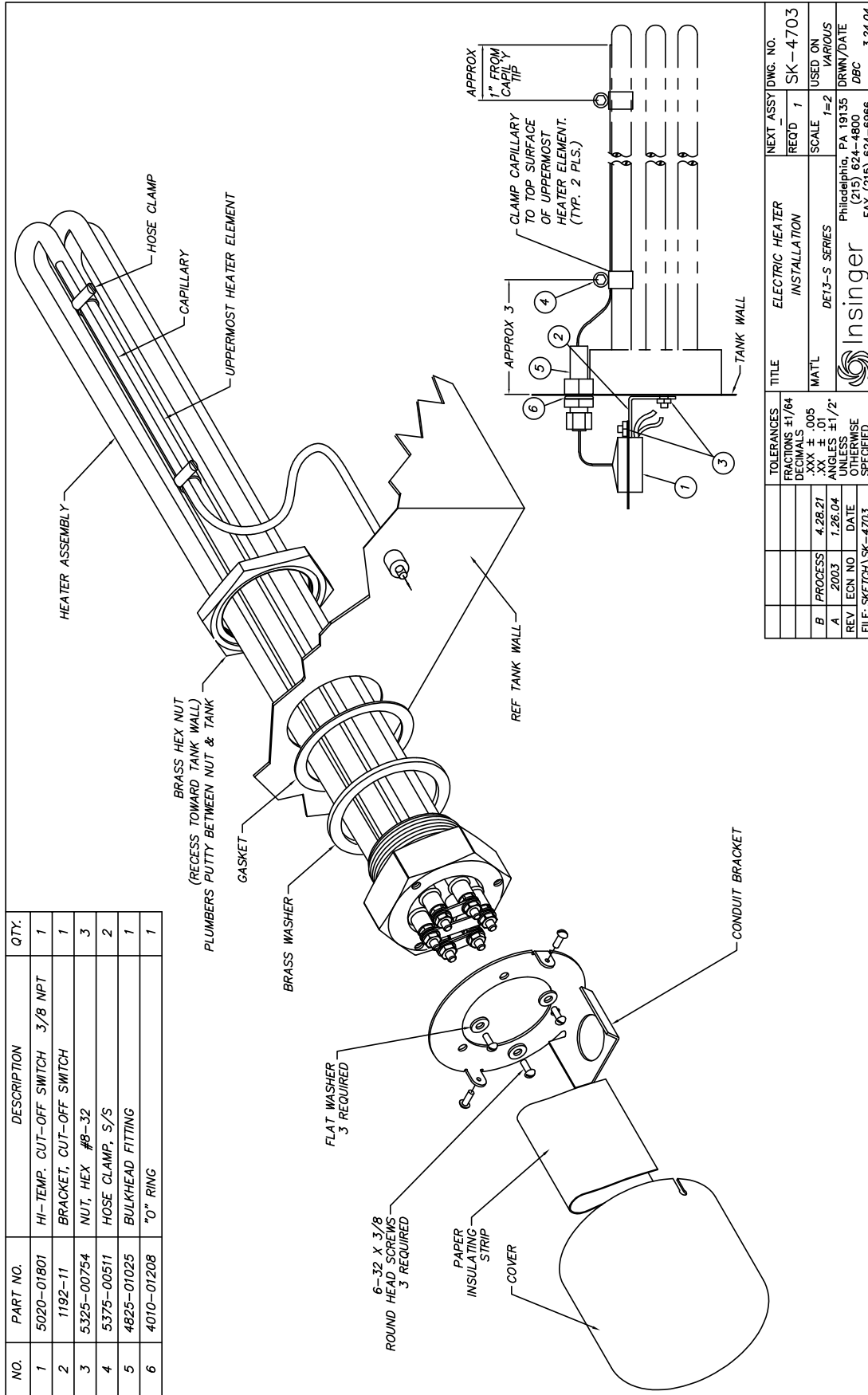

HOURS OF OPERATION

Insinger is available to assist you and your team day or night. Our regular business hours are Monday through Friday, 8:00 AM - 5:00 PM (EST). After-hours inquiries may take longer to respond.

CONTACTS

SALES

Kim Croft
Director of Business Development
E: kcroft@insingermachine.com
D: (215) 624-4800 x124
C: (630) 400-3656

David Baysinger
Regional Sales Manager
E: dbaysinger@insingermachine.com
D: (215) 624-4800 x111

ORDERS & QUOTES

Edward Gerhard
Account Manager
E: egerhard@insingermachine.com
D: (215) 624-4800 x116

Deniece Heard
Customer Service
E: dheard@insingermachine.com
D: (215) 624-4800 x120

MARKETING

Matthew Weisbecker
Strategic Marketing Manager
E: mweisbecker@insingermachine.com
D: (215) 624-4800 x131

SERVICE & SUPPORT

Jason Striker
Parts & Service Manager
E: jason@insingermachine.com
D: (215) 624-4800 x139

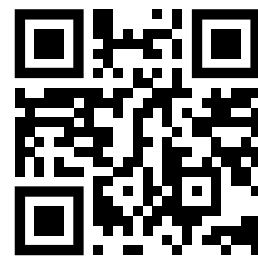

Digital Contact Cards

