



TECHNICAL MANUAL

Installation, Operation and Maintenance Instructions

ADMIRAL SERIES

Rack Conveyor Dishwasher

ADMIRAL 44-4

ADMIRAL 66-4

Insinger Machine Company
6245 State Road
Philadelphia, PA 19135-2996

800-344-4802

Fax: 215-624-6966

www.insingermachine.com



Thank you for purchasing this quality Insinger product.

On the space provided below please record the model, serial number and start-up date of this unit:

Model: _____

Serial Number: _____

Start-Up Date: _____

When referring to this equipment please have this information available.

Each piece of equipment at Insinger is carefully tested before shipment for proper operation. If the need for service should arise please contact your local Authorized Insinger Service Company.

A Service Network Listing is provided on our web site, www.insingermachine.com or call Insinger at 800-344-4802 for your local authorized servicer.

For proper activation of the *Insinger Limited Warranty* a SureFire™ Start-Up & Check-Out Service should be completed on your machine. Refer to the Introduction section in this manual for an explanation of Insinger SureFire™ Start-Up & Check-Out Program.

Please read the Insinger Limited Warranty and all installation and operation instructions carefully before attempting to install or operate your new Insinger product.

To register your machine for warranty by phone, fax or the internet or for answers to question concerning installation, operation, or service contact our Technical Services Department:

TECHNICAL SERVICE CONTACTS	
Toll-Free	800-344-4802
Fax	215-624-6966
E-mail	service@insingermachine.com
Web	www.insingermachine.com

TABLE OF CONTENTS

Part 1		
Technical Information		3-13
• Introduction		
• Cut-sheets & Installation Drawings		
• Warranties		
Part 2		
Installation Instructions		14-17
• Installation and Start-Up Procedures		
Part 3		
Operating Instructions		18
• Operating Procedures		
Part 4		
Cleaning Instructions		19
• Daily and Weekly Procedures		
Part 5		
Maintenance & Repair Procedures		20-22
• Maintenance & Repair Procedures		
• Basic Service Guide		
Part 6		
Electrical Schematics & Replacement Parts		23-32
• Machine Wiring Diagrams		
• Control Panel Layout & Component Drawings		
Part 7		
Spare Parts List		33
Part 8		
Replacement Parts		34-64
• Overall Assembly Drawings for: Admiral 44-4 Admiral 66-4		
• Drain Assembly		
• Motor/Pump Assembly		
• Conveyor & Chain Tensioner Assemblies		
• Rinse Converter		
• Scrap Screen Arrangement		
• Top Baffles and Curtain Location		
• Drive Mechanism Assembly		
• Final Rinse Assemblies		
• Electric Heaters & Boosters		
• Steam Coils, Injectors and Boosters		
• Discharge Lines Assemblies		
• Rear Track Assemblies		



ESSENTIAL SERIES

Project _____
Item _____
Quantity _____
CSI - 11400 _____
Approval _____
Date _____

ADMIRAL⁴⁴⁻⁴ Single Tank Conveyor Dishwasher

- Automatic conveyor, rack type, single tank dishwasher with recirculating wash and fresh water final rinse.
- 0.63 gallons per rack at 20 PSI
- Capacity is 233 (20" x 20") racks per hour or 5,825 dishes per hour
- CrossFire Wash System provides superior cleaning
- Error proof replacement with color-coded curtains

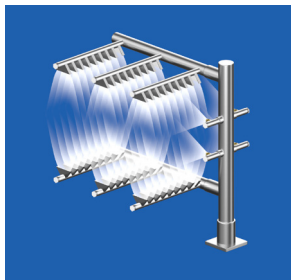

The patented CrossFire Wash System power sprays water horizontally, as well as, from above and below, cleaning and sanitizing the dirtiest of ware.

STANDARD FEATURES

- CrossFire Wash System
- Color-coded curtains
- Tank heat:
 - Electric immersion heater
 - Steam injector
- Manifold clean-out brush
- S/S 304 stainless steel construction
- Automatic tank fill
- Low water protection
- Single point electrical connection: motor, controls and tank heat. (Optional booster requires a separate connection)
- Detergent connection provision
- Elevated top mounted NEMA 12 control panel
- Door safety switches
- Standard frame drip proof motors
- Energy saver
- Override switch for de-liming
- SureFire Start-Up & Check-Out Service
- Ventilation fan connection provision
- End caps/pipe plugs secured to prevent loss
- Timing belt conveyor drive



OPTIONS

- Tank heat:
 - Steam coil
 - Infrared gas
- Built-in or stand alone electric booster heater
- Pressure reduction valve and line strainer
- Steam booster
- Vent cowl collar with adjustable damper controls
- Chemical sanitizer injector package for low temperature operations (Chemical pump supplied by others)
- Security package
- Totally enclosed motors
- Rack limit switch
- Power Loader
- Power Unloader
- Door activated drain closer
- Plastic 20" x 20" racks (plate or silver)





ADMIRAL⁴⁴⁻⁴

Single Tank Conveyor Dishwasher

Capacity Per Hour	233 racks 5825 dishes 225-500 meals
Tank Capacity	21 gals. (wash) 37 gals. (gas wash)
Motor Size	2 hp (wash) 1/15 hp (conveyor)
Electric Usage	17.5 kW tank 15 kW b.i. booster 40° rise 27 kW b.i. booster 70° rise 15 kW rem. booster 40° rise 27 kW rem. booster 70° rise
Gas Consumption	50,000 BTUH 49 CFH nat. gas 20 CFH propane
Steam Consumption at 20 psi min.	54 lbs./hour tank 52 lbs./hour booster 40° rise 91 lbs./hour booster 70° rise
Final Rinse Peak Flow at 20 psi min.	2.5 gallons/minute
Final Rinse Consumption at 20 psi min.	147 gallons/hour 0.63 gallons/rack
Exhaust Air Requirement	200 CFM Load 200 CFM unload
Peak Rate Drain Flow	9 gallons/minute
Installation distance from vertical combustible surface	2"
Shipping Weight	600 lbs.

Machine Electrical				*Booster Electrical	
Motors, Controls Tank Heat	Steam	Gas	Electric	40° Rise	70° Rise
240/1/60	14.3	14.3	87.2	62.5	112.5
208/3/60	8.5	9.2	57.1	41.7	75.0
240/3/60	7.8	8.5	49.9	36.1	65.0
480/3/60	3.9 4.7	4.2	25.0	18.1	32.5
380/3/50		5.1	31.3	23.0	38.1

SPECIFICATIONS

CONSTRUCTION- Hood and tank constructed of 16 gauge type 304 S/S. Hood unit of all welded seamless construction. S/S frame, legs and feet. All internal castings are non-corrosive lead free nickel alloy, bronze or S/S.

DOORS- Zero-Infringement Doors are extra large die formed, type 304 S/S, double-walled, insulated, front inspection doors. The vertically opening doors with spring assist, glide in full length tracks on either side. Automatic safety catch at full open locations.

CONVEYORS- One S/S roller chain conveyor, with rack driving lugs every sixth link, running along the front of the machine. Eight free spinning rollers placed along the back wall of the machine. Conveyor accommodates all standard 20" racks. Conveyor drive system includes direct drive gear motor with frictionless, trouble-free clutch system, spring-loaded and automatically re-engaging. Racks conveyed automatically through washing and rinsing systems, powered by an independent 1/15 hp drive motor.

PUMP- Centrifugal type "packless" pump with a brass petcock drain. Construction includes ceramic seal and a balanced cast impeller on a precision ground stainless steel shaft, extension or sleeve. All working parts mounted as an assembly and removable as a unit without disturbing pump housing. 2 hp motor, standard horizontal C-face frame, drip proof, internally cooled with ball-bearing construction.

CONTROLS- Top mounted NEMA 12 control enclosure, housing motor overload protection, contactors, transformers and all other dishwasher controls. All controls safe low voltage 24 VAC.

ENERGY SAVER- Rack actuated lever automatically operates the final rinse solenoid only when a rack passes, saving water and energy. The lever also activates an adjustable timer control. If no ware passes during the set time, the machine shuts down.

SPRAY SYSTEM- Spray arms made of type 304 stainless steel pipe. Spray assemblies removable without the use of tools.

WASH- Upper and lower manifolds with the patented CrossFire® Wash System. One manifold above with 3 power wash arms, each with 5 high pressure cleaning slots and one manifold below with 4 power wash arms, each with 7 high pressure cleaning slots. The slots are precision milled for water control producing a fan spray. Wash arms are fillet welded to the S/S manifold. The CrossFire® Wash System provides 2 horizontally spraying high pressure nozzles.

FINAL RINSE- Three nozzles above and four nozzles below threaded into S/S schedule 40 pipes. Nozzle assemblies produce a fan spray reducing water consumption, maximizing heat retention.

DRAIN- Drain valve externally controlled. Overflow assembly with skimmer cap is removable without the use of tools for drain line inspection. Heater is protected by low water level control.

Note: Exhaust requirements are for pant leg connections only. For hood type, CFM requirements vary, consult hood manufacturer for specific sizing.

Contact Insinger Sales at 800-344-4802 for an installation drawing specific to your application.
This drawing is available on the Insinger website at www.insingermachine.com

Note: Due to product improvement we reserve the right to change information and specifications without notice.

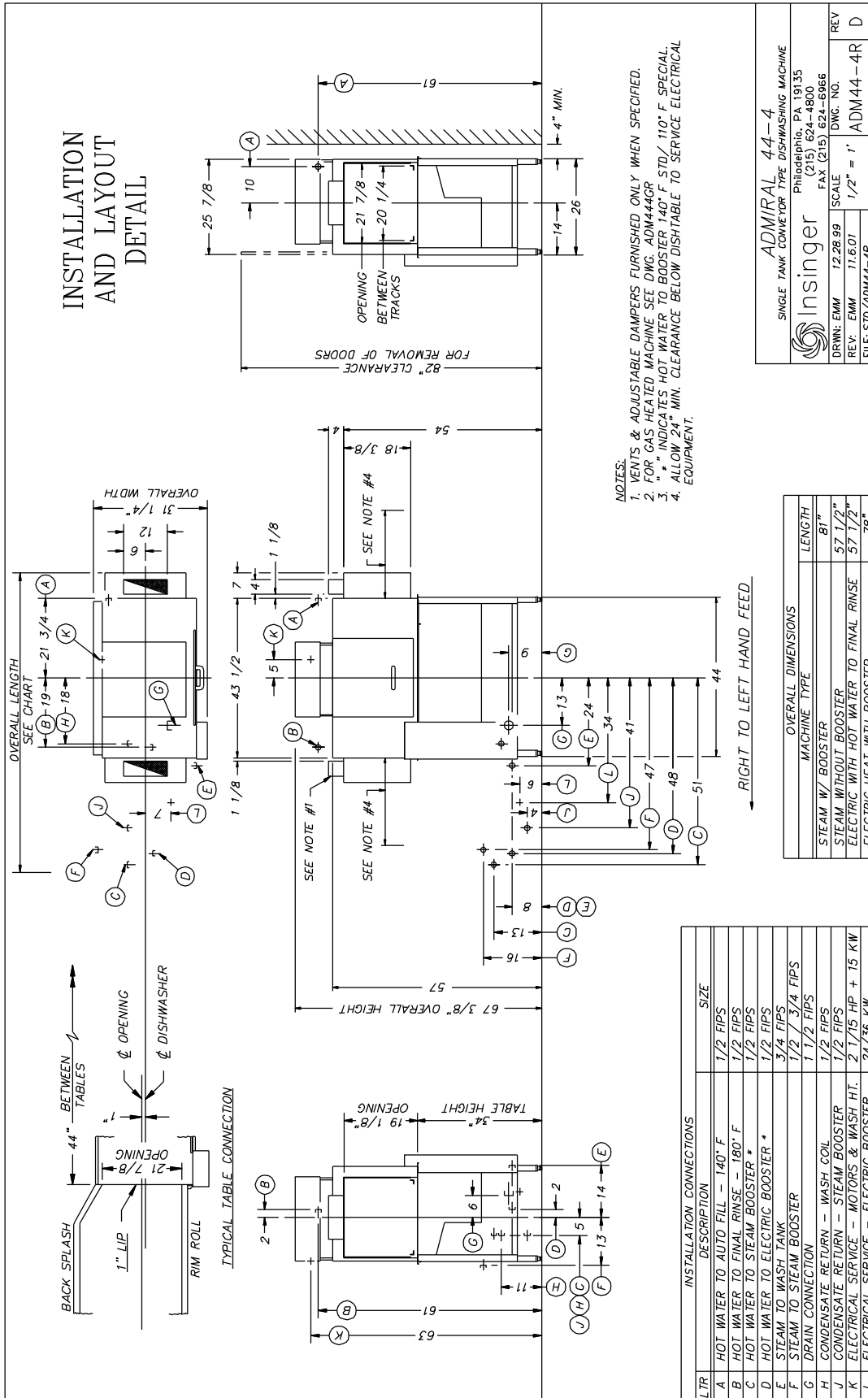

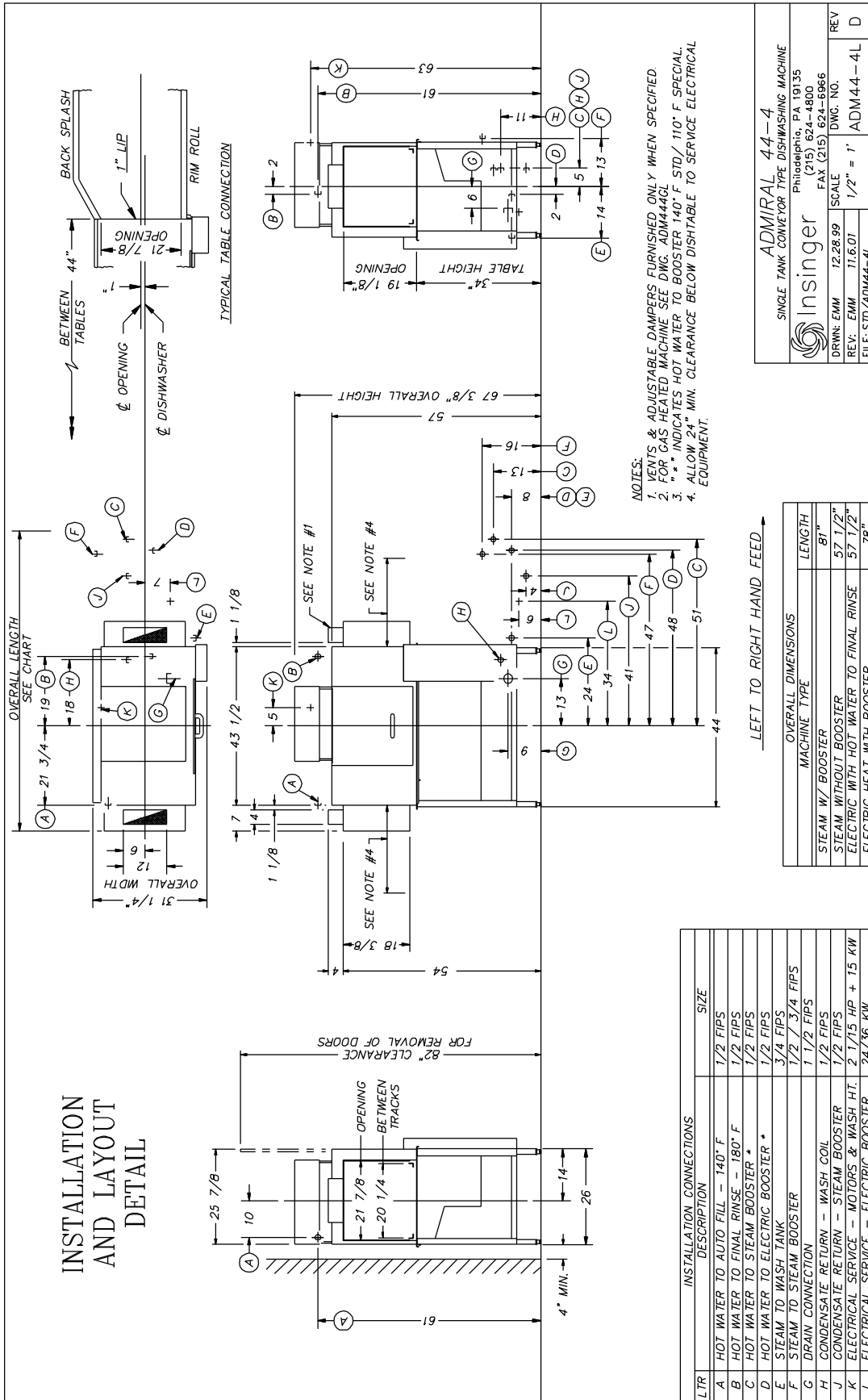

ADMIRAL 44-4
SINGLE TANK CONVEYOR TYPE DISHWASHING MACHINE

Insinger
Philadelphia, PA 19135
(215) 624-4800
FAX (215) 624-6966

DRWN: EMM 12.28.99 SCALE: 1/2" = 1'
REV: EMM 11.6.01 1/2" = 1' ADM44-4L
FILE: STD/ADM44-4L

REV D



ESSENTIAL SERIES

Project _____
Item _____
Quantity _____
CSI - 11400 _____
Approval _____
Date _____

ADMIRAL⁶⁶⁻⁴

Single Tank Conveyor Dishwasher with Recirculating Pre-wash

- Automatic conveyor, rack type, single tank dishwasher with recirculating pre-wash and wash and fresh water final rinse.
- 0.63 gallons per rack at 20 PSI
- Capacity is 233 (20" x 20") racks per hour or 5,825 dishes per hour
- CrossFire Wash System provides superior cleaning
- Wide access doors make daily maintenance easy and efficient
- Error proof replacement with color-coded curtains

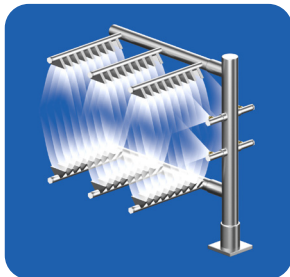

The patented CrossFire Wash System power sprays water horizontally, as well as, from above and below, cleaning and sanitizing the dirtiest of ware.

STANDARD FEATURES

- CrossFire[®] Wash System
- Color-coded curtains
- Tank heat:
 - Electric immersion heater
 - Steam injector
- Manifold cleanout brush
- S/S 304 stainless steel construction
- Automatic tank fill
- Low water protection
- Single point electrical connection: motor, controls and tank heat. (Booster requires a separate connection)
- Detergent connection provision
- Elevated top mounted NEMA 12 control panel
- Door safety switches
- Standard frame drip proof motors
- Energy saver
- Override switch for de-liming
- SureFire[™] Start-Up & Check-Out Service
- Ventilation fan connection provision
- End caps/pipe plugs secured to prevent loss
- Timing belt conveyor drive

OPTIONS

- Tank heat:
 - Steam coil
 - Infrared gas
- Built-in or stand alone electric booster heater
- Pressure reduction valve and line strainer
- Steam booster
- Vent cowl collar with adjustable damper controls
- Chemical sanitizer injector package for low temperature operations (Chemical pump supplied by others)
- Security package
- Totally enclosed motors
- Rack limit switch
- Power Loader
- Power Unloader
- Door activated drain closer
- Plastic 20" x 20" racks (plate or silver)





ADMIRAL⁶⁶⁻⁴ Single Tank Conveyor Dishwasher

Capacity Per Hour	233 racks 5825 dishes 225-500 meals
Tank Capacity	21 gals. (wash) 37 gals. (gas wash)
Motor Size	2 hp (wash) 1/15 hp (conveyor)
Electric Usage	17.5 kW tank 15 kW b.i. booster 40° rise 27 kW b.i. booster 70° rise 15 kW rem. booster 40° rise 27 kW rem. booster 70° rise
Gas Consumption	50,000 BTUH 49 CFH nat. gas 20 CFH propane
Steam Consumption at 20 psi min.	54 lbs./hour tank 52 lbs./hour booster 40° rise 91 lbs./hour booster 70° rise
Final Rinse Peak Flow at 20 psi min.	2.5 gallons/minute
Final Rinse Consumption at 20 psi min.	147 gallons/hour 0.63 gallons/rack
Exhaust Air Requirement	200 CFM Load 200 CFM unload
Peak Rate Drain Flow	9 gallons/minute
Installation distance from vertical combustible surface	2"
Shipping Weight	600 lbs.

Machine Electrical				*Booster Electrical	
Motors, Controls Tank Heat	Steam	Gas	Electric	40° Rise	70° Rise
240/1/60	14.3	14.3	87.2	62.5	112.5
208/3/60	8.5	9.2	57.1	41.7	75.0
240/3/60	7.8	8.5	49.9	36.1	65.0
480/3/60	3.9 4.7	4.2	25.0	18.1	32.5
380/3/50		5.1	31.3	23.0	38.1

SPECIFICATIONS

CONSTRUCTION- Hood and tank constructed of 16 gauge type 304 S/S. Hood unit of all welded seamless construction. S/S frame, legs and feet. All internal castings are non-corrosive lead free nickel alloy, bronze or S/S.

DOORS- Zero-Infringement Doors are extra large die formed, type 304 S/S, double-walled, insulated, front inspection doors. The vertically opening doors with spring assist, glide in full length tracks on either side. Automatic safety catch at full open locations.

CONVEYORS- One S/S roller chain conveyor, with rack driving lugs every sixth link, running along the front of the machine. Eight free spinning rollers placed along the back wall of the machine. Conveyor accommodates all standard 20" racks. Conveyor drive system includes direct drive gear motor with frictionless, trouble-free clutch system, spring-loaded and automatically re-engaging. Racks conveyed automatically through washing and rinsing systems, powered by an independent 1/15 hp drive motor.

PUMP- Centrifugal type "packless" pump with a brass petcock drain. Construction includes ceramic seal and a balanced cast impeller on a precision ground stainless steel shaft, extension or sleeve. All working parts mounted as an assembly and removable as a unit without disturbing pump housing. 2 hp motor, standard horizontal C-face frame, drip proof, internally cooled with ball-bearing construction.

CONTROLS- Top mounted NEMA 12 control enclosure, housing motor overload protection, contactors, transformers and all other dishwasher controls. All controls safe low voltage 24 VAC.

ENERGY SAVER- Rack actuated lever automatically operates the final rinse solenoid only when a rack passes, saving water and energy. The lever also activates an adjustable timer control. If no ware passes during the set time, the machine shuts down.

SPRAY SYSTEM- Spray arms made of type 304 stainless steel pipe. Spray assemblies removable without the use of tools.

WASH- Upper and lower manifolds with the patented CrossFire® Wash System. One manifold above with 3 power wash arms, each with 5 high pressure cleaning slots and one manifold below with 4 power wash arms, each with 7 high pressure cleaning slots. The slots are precision milled for water control producing a fan spray. Wash arms are fillet welded to the S/S manifold. The CrossFire® Wash System provides 2 horizontally spraying high pressure nozzles.

FINAL RINSE- Three nozzles above and four nozzles below threaded into S/S schedule 40 pipes. Nozzle assemblies produce a fan spray reducing water consumption, maximizing heat retention.

DRAIN- Drain valve externally controlled. Overflow assembly with skimmer cap is removable without the use of tools for drain line inspection. Heater is protected by low water level control.

Note: Exhaust requirements are for pant leg connections only. For hood type, CFM requirements vary, consult hood manufacturer for specific sizing.

Contact Insinger Sales at 800-344-4802 for an installation drawing specific to your application.
This drawing is available on the Insinger website at www.insingermachine.com

Note: Due to product improvement we reserve the right to change information and specifications without notice.

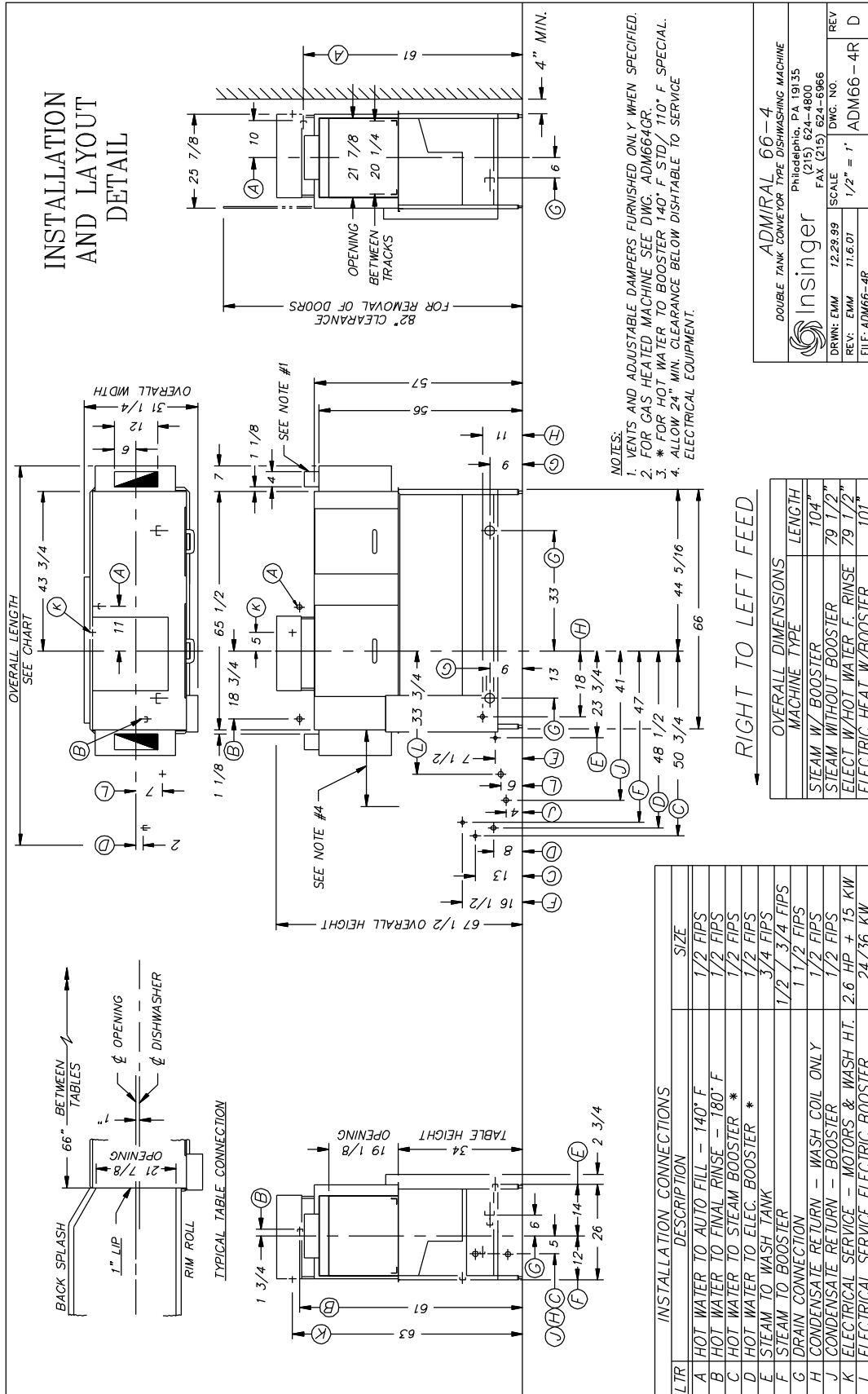

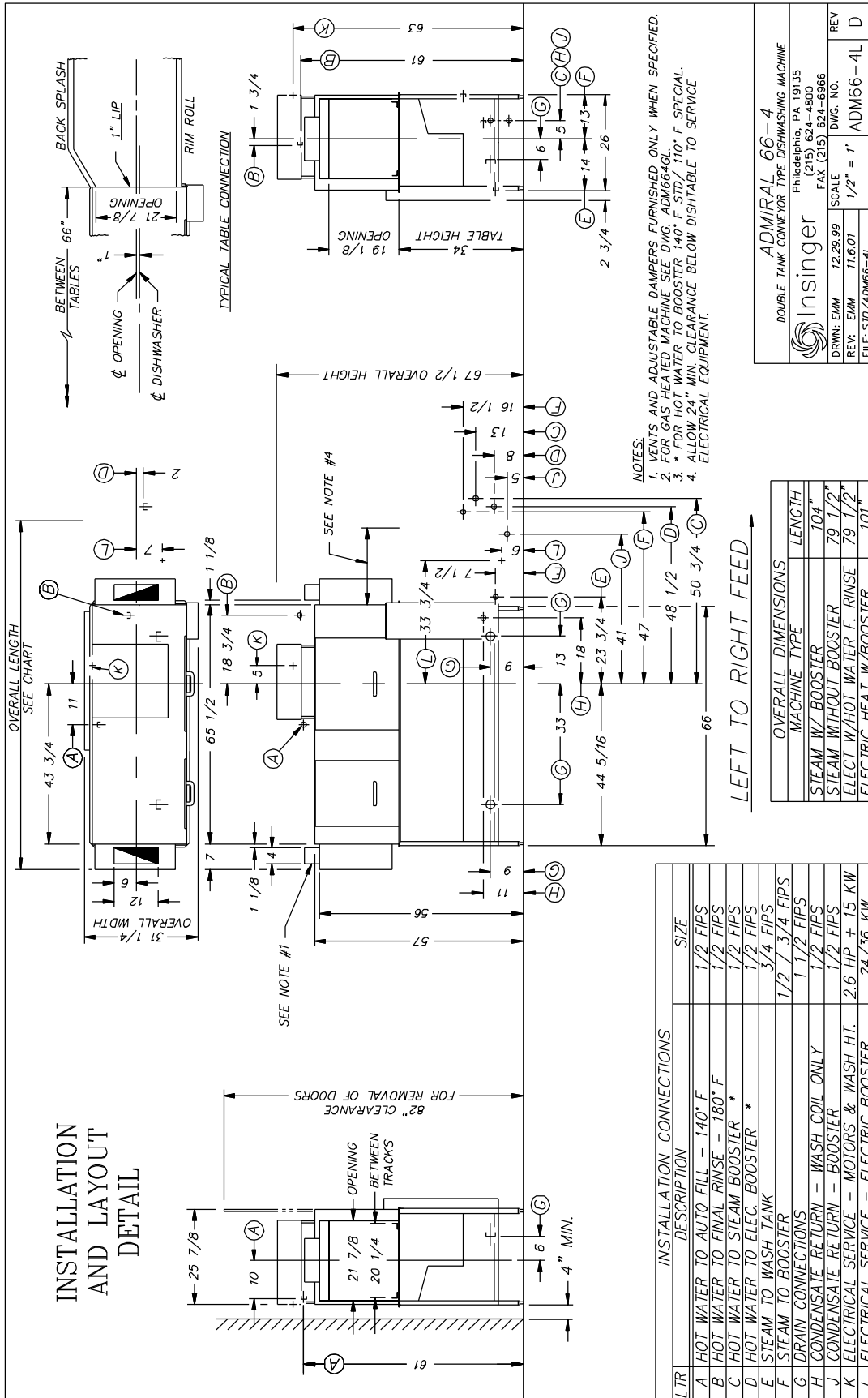

ADMIRAL RACK CONVEYOR SERIES

INTRODUCTION

Purpose

The purpose of this technical manual is to provide installation, operation, cleaning and maintenance directions.

A section is provided for replacement parts.

Scope

This manual contains all pertinent information to assist in the proper installation, operation, cleaning, maintenance, and parts ordering for Insinger Rack Conveyor Admiral Dishwasher Series.

The **installation instructions** are intended for qualified equipment installers. The **operation and cleaning instructions** are intended for the daily users of the equipment. The **maintenance and parts sections** are intended for qualified service and/or maintenance technicians. Replacement parts may be ordered directly from our factory or from your local Insinger Authorized Service Agency. You can speak to the **Insinger Technical Services Department, 800/344-4802**, or e-mail us at **service@insingermachine.com**. When calling for warranty information or replacement parts please provide the model and serial number of your Insinger Equipment. These important numbers should be noted in this manual on the spaces provided on the opening page.

Surefire™ Start-up & Check-out Program
Insinger is proud to offer our exclusive Surefire™ Start-up & Check-out Program to our commercial customers. This service is included in the purchase price of your new Insinger dishwasher. We will provide an authorized factory service technician for the initial start-up of your new Insinger dishwasher to ensure it is running at optimum levels from the very first pass. Please call the factory or your local Insinger Sales Representative to schedule this service.

NSF 3-2003 requirements for detergent and chemical sanitizer dispensers.

This machine must be operated with an automatic detergent dispenser and, if applicable, an automatic chemical sanitizer feeder, including a visual means to verify that detergents and sanitizers are delivered or a visual or audible alarm to signal if detergents and sanitizers are not available for delivery to the respective washing and sanitizing systems. Please see instructions for electrical and plumbing connections located in this manual and in the feeder equipment manual.

Definitions

Throughout this guide you will find the following terms: WARNING, CAUTION, & NOTE.

WARNING indicates potential physical danger.
CAUTION indicates potential equipment damage.
NOTE indicates helpful operating hints or tips.

You will visually be able to identify each as shown below:



WARNING:
Indicates potential physical danger.



NOTE:
Indicates helpful operating hints or tips.

CAUTION:

Indicates potential equipment damage.

INSINGER MACHINE COMPANY LIMITED WARRANTY

Insinger Machine Company, Inc. (Insinger) hereby warrants to the original retail purchaser of this Insinger Machine Company, Inc. product, that if it is assembled and operated in accordance with the printed instructions accompanying it, then for a period of either 15 months from the date of shipment from Insinger or 1 year (12 months) from the date of installation, that said Insinger product shall be free from defects in material and workmanship. Whichever one of the two aforesaid limited warranty time periods is the longest shall be the applicable limited warranty coverage time period.

Insinger may require reasonable proof of your date of purchase; therefore, you should retain your copy of invoice or shipping document.

This limited warranty shall be limited to the repair or replacement of parts which prove defective under normal use and service and which on examination shall indicate, to Insinger's satisfaction, they are defective. Any part that is claimed to be defective and covered by this limited warranty must be returned to Insinger, this may be done through an Authorized Service Agency. Furnish serial number of machine with shipment and send to:

*Insinger Machine Company
6245 State Road
Philadelphia, PA 19135-2996*

If Insinger's inspection confirms the defect and the claim, Insinger will repair or replace such part without charge and return it to you freight or postage prepaid.

This limited warranty does not cover any failure or accident, abuse, misuse, alteration, misapplication, improper installation, fire, flood, acts of God or improper maintenance or service, or failure to perform normal and routine maintenance as set out in

the instruction booklet (operating instructions) or for improper operation or failure to follow normal operating instructions (as set out in the instruction booklet). Insinger is not responsible nor liable for any conditions of erosion or corrosion caused by corrosive detergents, acids, lye or other chemicals used in the washing and or cleaning process.

Service must be done by either Insinger Appointed Service Agencies or agencies receiving prior authorization from Insinger.

All warranty work must be done during normal working hours, unless purchaser receives prior authorization from Insinger.

There are no other express warrants except as set forth herein and any applicable implied warranties of merchantability and fitness are limited in duration to the period of coverage of this express written limited warranty. This limited warranty supersedes all other express warranties, implied warranties of merchant-ability and fitness or limited warranties as of this date, January 1, 1998. Some states do not allow limitation on how long an implied warranty lasts so this limitation may not apply to you.

Insinger is not liable for any special, indirect or consequential damages. Some states do not allow the exclusion or limitation of incidental or consequential damages, so this limitation nor exclusion may not apply to you.

Insinger does not authorize any person or company to assume for it any other obligation or liability in connection with the sale, installation, use, removal, return or replacement of its equipment: and no such representations are binding on Insinger.

**INSINGER MACHINE COMPANY LIMITED WARRANTY
COMMERCIAL MARINE USE**

Insinger Machine Company, Inc. (Insinger) hereby warrants to the original retail purchaser of this Insinger Machine Company, Inc. product, that if it is assembled and operated in accordance with the printed instructions accompanying it (installation manual), then for a period of 18 months from the date of installation on board the vessel, that said Insinger product shall be free from defects in material and workmanship.

Insinger may require reasonable proof of your date of equipment install, therefore, you should retain your copy of invoice or shipping document.

This limited warranty shall be limited to the replacement of parts which prove defective under normal use and service and which on examination shall indicate, to Insinger's satisfaction, they are defective. Any part that is claimed to be defective and covered by this limited warranty must be returned to Insinger. Furnish serial number of machine with shipment and send to:

*Insinger Machine Company, Inc.
6245 State Road
Philadelphia, PA 19135-2996*

If Insinger's inspection confirms the defect and the claim, Insinger will repair or replace such part without charge and return it to you freight or postage prepaid. If part damages are not covered, Insinger will contact the customer and advise.

If a factory trained authorized technician is required to repair or replace defective parts or material during the 18 month warranty period, the cruise line will be responsible for the payment of travel expense and a minimum of four hours labor.

Labor will be billed to the customer at a reduced rate of \$40.00 per hour. If sailing with a vessel is required, then an eight hour per day minimum will apply.

This limited warranty does not cover accident, abuse, misuse, alteration, misapplication, improper installation, fire, flood, or improper maintenance or service, or failure to perform normal and routine maintenance as set out in the instruction booklet (operating instructions) or for improper operation or failure to follow normal operating instructions (as set out in the instruction booklet).

Insinger is not responsible nor liable for any conditions of erosion or corrosion caused by corrosive detergents, acids, lye or other chemicals used in the washing, caring and or cleaning process.

Warranty service must be done by either Insinger Appointed Service Agencies or agencies, customers galley engineers receiving prior authorization from Insinger.

There are no other express warrants except as set forth herein and any applicable implied warranties of merchantability and fitness are limited in duration to the period of coverage of this express written limited warranty. This limited warranty supersedes all other express warranties, implied warranties of merchantability and fitness or limited warranties as the above date.

Insinger does not authorize any person or company locally or overseas to assume for it any other obligation or liability in connection with the sale, installation, use, removal, return or replacement of its equipment; and no such representations are binding on Insinger.

INSTALLATION INSTRUCTIONS

Placement

Carefully uncrate machine. Take caution not to damage components which may be mounted on the top or sides of the machine. Set unit in place and adjust the feet to level the machine.

Fasten the tables to the load and unload side of the machine. Most installations require fastening the turn-down lip of the dish table to the side of the machine with flathead counter-sunk screws. The table design should provide horizontal clearance of 30" for servicing underneath the table.

Electrical Connections

Connect electrical lines sized for the correct voltage, current and phase of the machine. These should agree with the machine requirements indicated on the nameplate and labels on the control panel.

On machines not provided with a single-point connection (optional) there is an electrical connection required for the: **1.** Pumps and control circuit, **2.** Wash tank heater(s) and, **3.** Rinse tank heaters (if provided).

If an electric booster is provided, connect power directly to the booster.

Fusing must be in accordance with the Fuse Sizing Chart below.

CAUTION:

Connections must be made to a circuit breaker or fused disconnect as provided by the end-user and required by local codes.

A laminated wiring diagram is inside the control panel.

FUSE SIZING CHART

Model	208VAC/3Ë	230VAC/3Ë	380VAC/3Ë	460VAC/3Ë	220VAC/1Ë
Admiral 44-4 Steam or Electric	15A	10A	10A	6A	20A
Admiral 44-4 Steam or Electric Power Loader	15A	15A	10A	6A	25A
Admiral 44-4 Steam or Electric Power Unloader	15A	15A	10A	10A	25A
Admiral 44-4 Steam or Electric Power Loader Power Unloader	20A	15A	10A	10A	25A
Admiral 44-4 Gas Heat	15A	15A	10A	6A	20A
Admiral 44-4 Gas Heat Power Loader Power Unloader	15A	15A	10A	10A	25A
Admiral 44-4 Admiral 66-4 Electric Heat Single-Point Electric	60A	50A	30A	25A	n/a
Admiral 44-4 Electric Heat Single-Point Electric Power Unloader	60A	50A	30A	25A	n/a

FUSE SIZING CHART					
Model	208VAC/3È	230VAC/3È	380VAC/3È	460VAC/3È	220VAC/1È
Admiral 44-4 electric heat single-point electric power unloader	60A	50A	35A	25A	n/a
Admiral 44-4 electric heat single-point electric power loader power unloader	60A	50A	35A	25A	n/a
Admiral 66-4 steam or electric	15A	15A	10A	6A	25A
Admiral 66-4 steam or electric power loader	15A	15A	10A	10A	35A
Admiral 66-4 steam or electric power unloader	20A	15A	10A	10A	30A
Admiral 66-4 steam or electric power loader power unloader	20A	20A	10A	10A	30A
Admiral 66-4 gas heat	15A	15A	10A	10A	25A
Admiral 66-4 gas heat power loader or unloader	20A	15A	10A	10A	30A
Admiral 66-4 gas heat power loader and unloader	20A	15A	10A	10A	35A
Admiral 66-4 electric heat single-point electric power loader or unloader	60A	50A	35A	25A	n/a
Admiral 66-4 electric heat single-point electric power loader and unloader	60A	60A	35A	30A	n/a
Admiral 44-4 ¹ Admiral 66-4 ¹ electric heat non-SPC	60A	45A	30A	25A	80A

¹ This circuit is required for all machines with electric tank heat that are not configured for single point connection.

CAUTION:

As with any 3 phase system, an electrician must check all motors for proper phasing, i.e., pump motors must be running in direction indicated by arrow on housing.

Mechanical Connections

Connect water lines for tank fills as tagged and noted on the installation drawings.

If machine is provided with steam heat connect the steam lines and steam condensate lines as tagged and noted on installation drawings. If machine is provided with gas heat, connect the gas line.

If a booster is provided a hot water connection is necessary (110° F or 140° F).

CAUTION:

Drain lines must be as specified on installation drawings.

Drain line should be properly vented and should have fall of not less than 1/4" to the foot of proper flow.
Some area plumbing codes require drains to flow into an open gap with an opening twice the diameter of the pipe.

Check with your local plumbing codes for the type of drain connection required.

CAUTION:

All lines must be flushed prior to use to remove debris.

CAUTION:

Do not reduce the size of lines as specified in installation drawings. All lines are sized to facilitate necessary flows, pressures, etc.

HVAC

The ventilation system should be sized to provide adequate ventilation per machine specs. Refer to spec sheet.

Stainless steel, watertight ducting should be connected to the vent cowls (optional) on each end of the machine.

Chemicals

Upon the completed installation of the dishwasher, contact a local detergent/chemical supplier for the correct chemicals for your soil load and geographical area.

Electrical connection points for the detergent dispenser and rinse injector are located inside the control panel. Refer to the wiring diagram for this machine for the proper connection points.

Dispensers may be connected on either the primary voltage side of the machine or the 24VAC control voltage side.

CAUTION:

When connecting on the 24VAC control voltage side of the transformer, total VA *must* not exceed 5Kva.

The detergent density probe can be placed in the provided hole (labeled "Detergent Probe") in the wash tank.

Tabling

Load and unload tables should be pitched towards the machine to return excess water into the machine.

CAUTION:

Machines with unload tables less than 48" should utilize a rack limit switch to shut the machine down if clean racks pile-up. This extends the life of the drive system.

Initial Start-Up Adjustments

Tank Overfill Adjustment

1. Locate tank overfill timer in the control panel. See the control panel layout drawing located in Section 6, Electrical Schematic and Replacement Parts.
2. The overfill timer starts timing when the upper level float is actuated. Adjust the overfill timer potentiometer to turn the tank fill solenoid off when the water level is 1/4" below the lip of the overflow tube.
3. The timer has a built in dwell timing delay of 5 seconds (nominal to dampen float bounce caused by tank water motion).

Conveyor Jam Adjustment

1. Remove the mechanism guard to gain access to the conveyor drive.
2. Locate the compression spring (refer to Drawing #1397-1, Drive Mechanism Assembly).
3. The factory set compression dimension is a nominal 3 13/16". Installations washing heavier ware may need to adjust this for more compression to keep the machine from shutting down prematurely.
4. Should the drive mechanism switch be activated by a conveyor jam, the Check Conveyor Light on the control panel will illuminate and the machine will shut down.
5. To restart the machine, clear the jam and press the green Start Button.

Final Rinse Pressure Adjustment

1. The final rinse pressure must be adjusted to 20PSI. This is done by adjusting the pressure regulator.

Insinger dishmachines are user-friendly, making them the easiest dishmachines on the market to operate and maintain.

By following these operating procedures your Insinger dishwasher will give you years of trouble free service.

OPERATION INSTRUCTIONS

1. Ensure drain overflow tube is in place. Close all tank drain valves. One drain is provided for each tank of the dishmachine.
2. Check for proper installation and cleanliness of all internal, removable components such as suction strainers, scrap screens, and spray manifolds.
3. Ensure all water, steam, and gas lines are open. Ensure electrical circuits are on.
4. Close machine doors.

p **NOTE:**
An interlock is provided to shut the machine down if the doors are open, therefore the machine will not run if the doors are opened.

5. Move the power toggle switch to the ON position.
6. The machine will begin to fill.
7. When the tanks are full the tank heat will operate automatically.

CAUTION:

To ensure proper operation of the auto tank fill feature and the tank heaters, the tank level floats **MUST** be cleaned daily.

8. Depress the GREEN button to start the conveyor.
9. The system is now ready for operation. All ware should be properly scrapped. Do not overload racks.

CAUTION:

Overloading racks will impede proper cleaning of the ware and also put extra strain on the conveyor system.

10. Slide the rack into the dishmachine, the conveyor
11. will pass the rack through the various machine cycles. Upon entering the final rinse section of the machine the rack will engage the final rinse actuator allowing the water to sanitize the dishes.
12. Should a conveyor jam occur, the CHECK CONVEYOR light will illuminate and the machine will shutdown. To re-start the machine, clear the conveyor jam and press the GREEN START button. If the CHECK CONVEYOR light comes back on, contact a qualified service technician.
13. Upon completion of ware cleaning depress the RED button to stop the conveyor system.
14. Move the POWER toggle switch to the OFF position.
15. Refer to the cleaning procedures for proper cleaning of the dishmachine.
16. Report any unusual occurrences to qualified service personnel.

The following cleaning procedures should be done daily, at the end of the shift.

DAILY CLEANING PROCEDURES

1. Remove all internal removable parts including spray manifolds, scrap screens, drain overflow tubes, suction strainers and curtains.
2. Remove the end caps from the spray manifolds and clean with the brush provided. Flush the manifolds.
3. Flush scrap screens.
4. Clean drain overflow tube.

p NOTE:
V-cup seal on the drain overflow tube may become gummed not allowing the overflow tube to seal. This will cause the drain to leak water. Remove any build-up on the V-cup seal. When the seal becomes worn, replace with part # D2-557.

5. Clean the suction strainers of build-up.

p NOTE:
Improper cleaning of the suction strainers will cause the pumps to cavitate. This will cause poor washing results.

6. Clean the tank level float with a plastic abrasive pad (do not use steel wool).

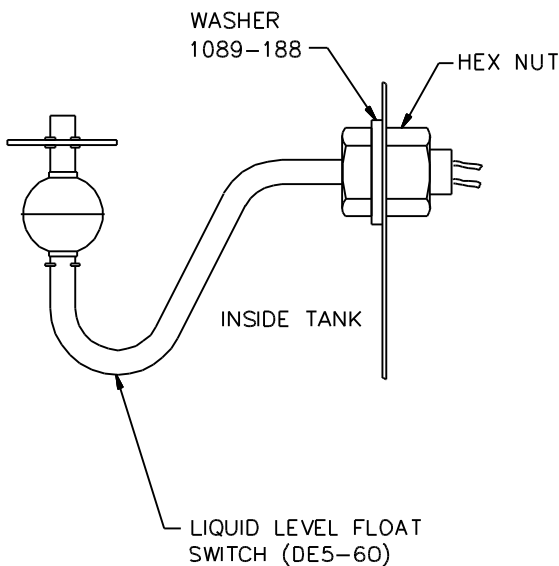

p NOTE:
Level floats must be cleaned daily. Build-up of grease and dirt will cause faulty operation of the tank fill heating system.

The LIQUID LEVEL FLOAT is located below the scrap screens in those tanks which contain water heating devices (coils, steam injectors, or electric immersion heaters) and pump inlet strainers. They are usually located, in rackless and rack conveyor style machines, on the inside tank wall, at approximately water level, opposite and parallel to the inspection doors. In the door, stationary rack type machines, the LIQUID LEVEL FLOAT may be found beneath the scrap screen.

7. Clean curtains. When the curtains are beyond cleaning or torn they should be replaced.
8. Clean final rinse nozzles of matter clogging the jet spray.
9. Leave the doors open to allow the drying of the interior surfaces.

WEEKLY CLEANING PROCEDURES

An ENERGY SAVER SWITCH is provided on the control panel. When running the machine with de-liming solution, place this switch in the OFF position to allow the machine to run continuously. When not de-liming, the switch should be in NORMAL. Consult your detergent supplier for de-liming solution concentration and frequency of use.

The following is a basic guide for the repair and replacement of common dishwasher parts. Refer to the Basic Services Guide for troubleshooting tips.

MAINTENANCE REQUIREMENTS

Daily

1. Refer to the operations and cleaning instructions provided in this manual for daily cleaning procedures.

Weekly

1. The entire machine should be wiped down using an industrial grade stainless steel cleaner.
2. Under the supervision of your detergent supplier the machine interior must be properly de-limed.
3. A switch is provided on the control panel to run the machine continuously. For de-liming, move the selector switch to the DE-LIME position, then operate the machine normally. When de-liming is completed, return the selector switch to "normal".

p NOTE:
The water quality in some areas requires de-liming to be done more frequently. Contact your detergent supplier for recommended de-liming frequency.

Quarterly

1. Remove and clean the strainer screens on the water and steam lines. If the screens cannot be cleaned, replace.
2. Inspect the condition of the solenoid valve seats, and diaphragms. Replace where necessary.
3. Inspect drain O-Rings for leakage. Replace where necessary.
4. Grease the drive chain and sprockets.
5. Adjust conveyor chain tension using adjustment bolts located on the exit ends of the machine.

MAINTENANCE PROCEDURES

Solenoid Valve Disassembly

1. Disconnect the power supply to the machine. Turn off the water supply.
2. Remove cap on top of the coil. Remove the coil.
3. Remove the 4 hex bolts and lift bonnet from valve body. Note positioning of spring and plunger.
4. Remove main piston.
5. Inspect for dirt, wear or lime build-up. Clean or replace as required.
6. Reassemble in reverse of disassembly.

Liner Strainer Disassembly

1. Shut off water or steam supply.
2. Remove large hex nut on bottom of strainer body.
3. Remove strainer screen. Inspect and clean or replace as necessary.
4. Reassemble in reverse of disassembly. Water flow must be same direction as arrow on line strainer body. Use new gaskets to insure a tight seal.

Pump Disassembly

1. Before disassembling pump ensure there are no obstructions in the pump intake. Remove and clean the suction strainer (inside tank). See dwg. SK-2456A

p NOTE:
It is not necessary to remove the pump housing from the machine to disassemble pump.

2. Remove the pump motor and impeller by removing the 4 hex bolts attaching them to the pump housing.
3. Repair or replace the pump parts as required.
4. Reassemble in reverse of disassembly.

MAINTENANCE PROCEDURES

Immersion Heater Replacement

1. The immersion heater **MUST** be completely submerged at all times. If this is not the case contact a qualified service technician. The heated surface should never be in contact with sludge. See dwg. SK-4703.
2. Remove the housing covering the wiring terminations. Disconnect the immersion heater wires.
3. Remove the immersion heater by loosening and removing the large hex nut.
4. Install in reverse of removal.

p NOTE:
Use plumbers putty as gasketing around the immersion heater to minimize leaks.

Tank Heat Temperature Adjustment

1. A temperature control board is provided in the control panel for easy adjustment of tank temperature. Though tank temperature is adjusted during the machines factory test it is sometimes necessary to re-adjust the temperature at start-up.
2. Locate the temperature control board (P/N DE9-96). Use the control panel layout drawing located in Section 4, Electrical Schematic and Replacement Parts.
3. Adjust the tank temperature to the desired temperature by turning the potentiometer located on the temperature control board. An arrow on the potentiometer indicates increase.
4. If the temperature does not change refer to Troubleshooting Tank Temperatures in the section below.

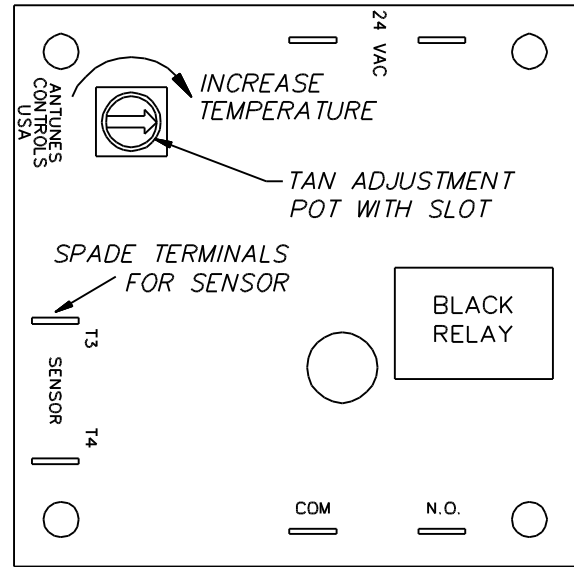

TANK TEMPERATURE CONTROL BOARD
(DE9-251)

Troubleshooting Tank Temperatures

Electric Heat

1. If temperature does not change check the temperature control board (P/N DE9-251) proper operation. If the temperature control board is faulty, replace.
2. Verify tank heat contactor is working correctly. If not, replace.
3. Verify all immersion heaters are working properly and not limed. If not, replace.

Steam Heat

1. If temperature does not change check the temperature control board (P/N DE9-251) proper operation. If the temperature control board is faulty, replace.
2. Verify steam pressure per machine specifications.
3. Verify steam trap is not clogged. If so, replace.

Motor Overloads

All motors used on Insinger Machines are provided with motor overloads. Motor overloads are adjusted when the machines are factory tested. Should it be necessary to adjust the motor overloads in the field first verify the motor current draw for the voltage the machine is using.

Using the Control Panel Component Layout Dwg. located in Section 3 to identify the overload adjust by turning the dial to the appropriate AMP draw.

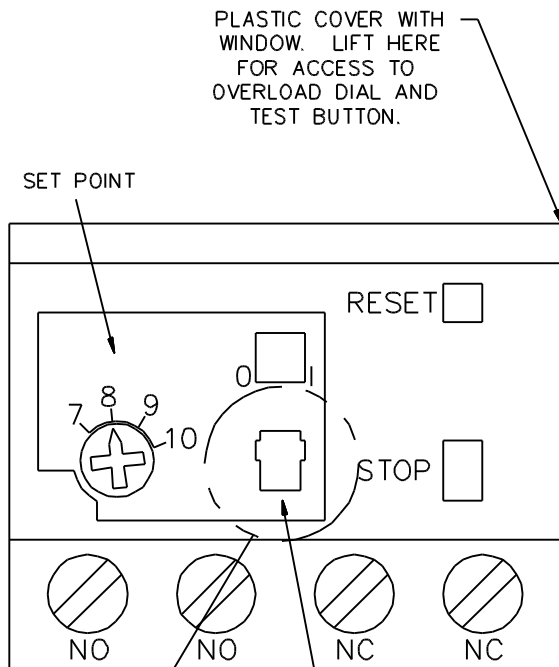

TO CHANGE FROM MANUAL TO AUTO RESET:

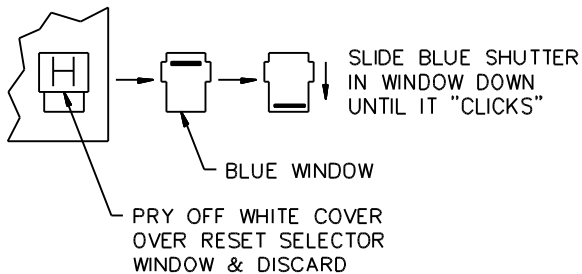

SKETCHA\SK-3829 OVERLOAD RELAY

Level System

The level control system consists of one overflow timer (P/N DE7-35) and one level float (P/N DEF-60) per tank.

When the system is powered-up, the tank(s) will begin to fill (assuming no water is in the tanks).

When the level float is actuated, the overflow timer begins to time-out and continues the filling process until the tank(s) is full.

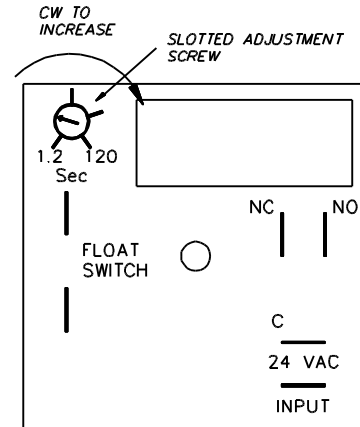

Liquid Level Timer DE7-35
SK-4698

Final Rinse Actuator

The final rinse is actuated by a level located on the rear wall of the dishwasher near the exit end. When a rack depresses it a switch is closed and a solenoid energized.

The activation of the lever also resets the Energy Saver Timer (P/N DE7-28). The timer will then start counting from 0. The timer is adjustable between 0 and 300 seconds (5 minutes). See dwg. 116-145.

NOTE:
The overflow timer **MUST** be adjusted during initial start-up. Adjustment depends on water fill pressure. The water level **MUST** be 1/4" below the lip of the overflow tube. Adjust by increasing or decreasing the potentiometer on the level timer.

NOTE:
Dirty level floats will cause the tank heat to energize with no water in the tanks. **LEVEL FLOATS MUST BE CLEANED DAILY.**

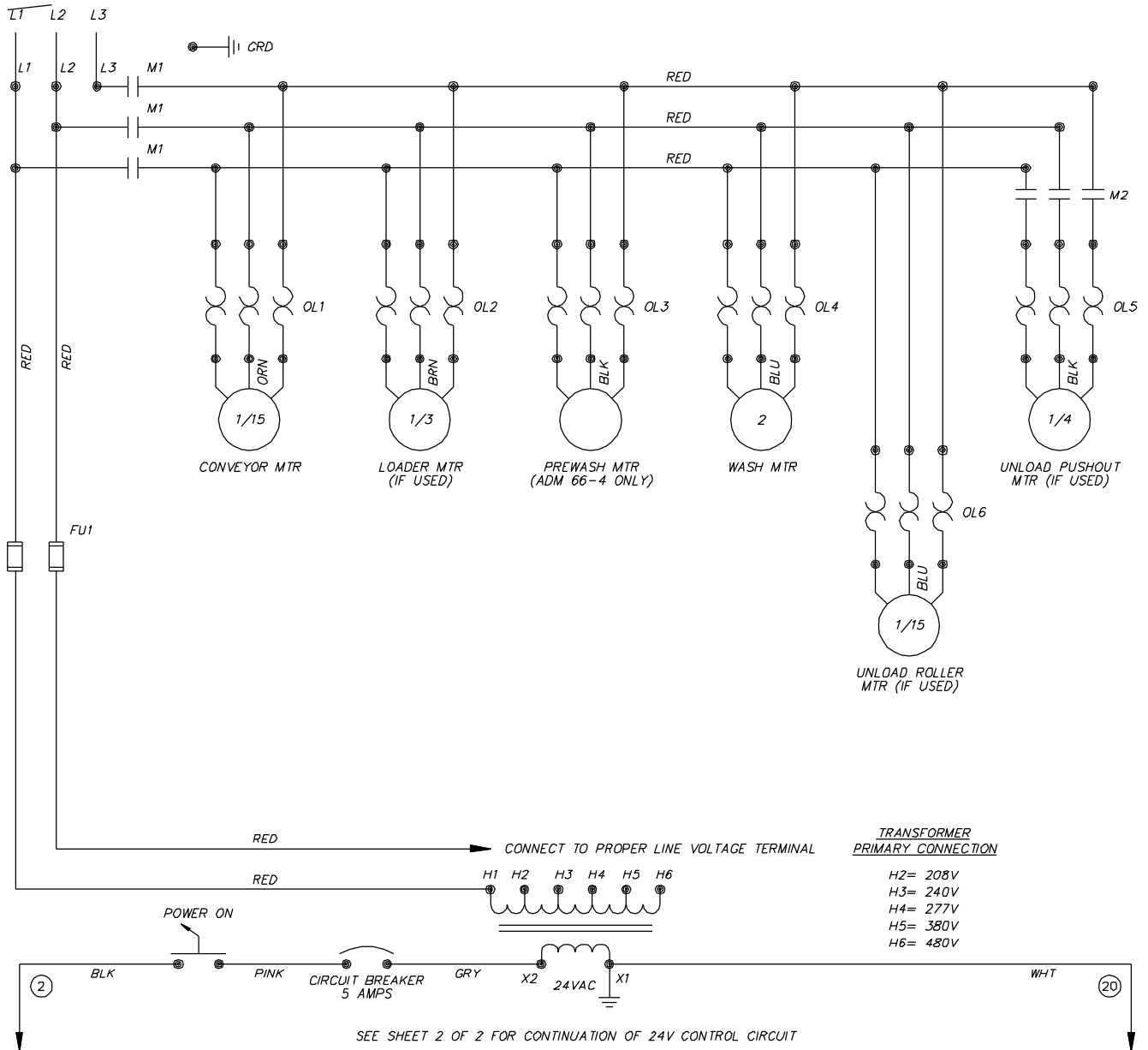

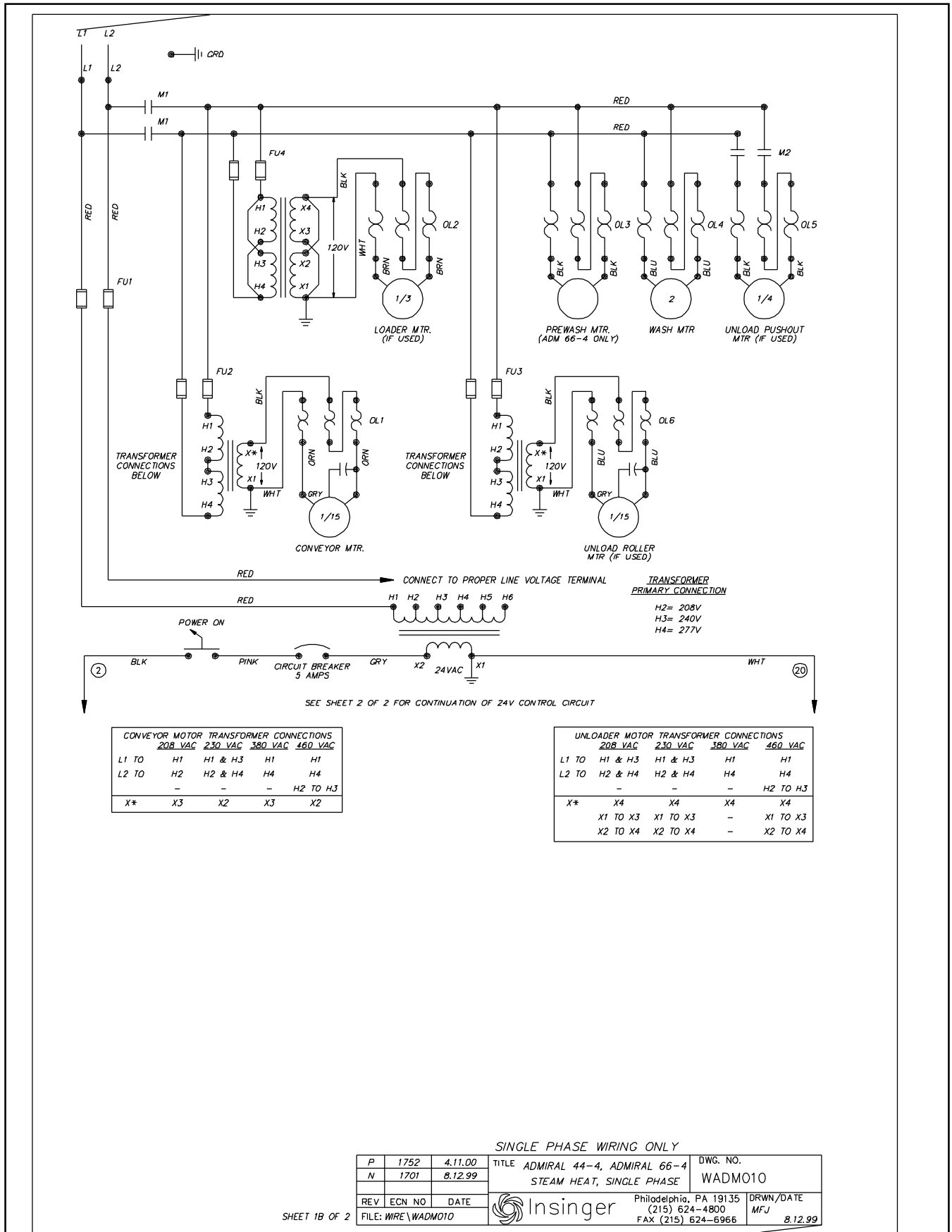

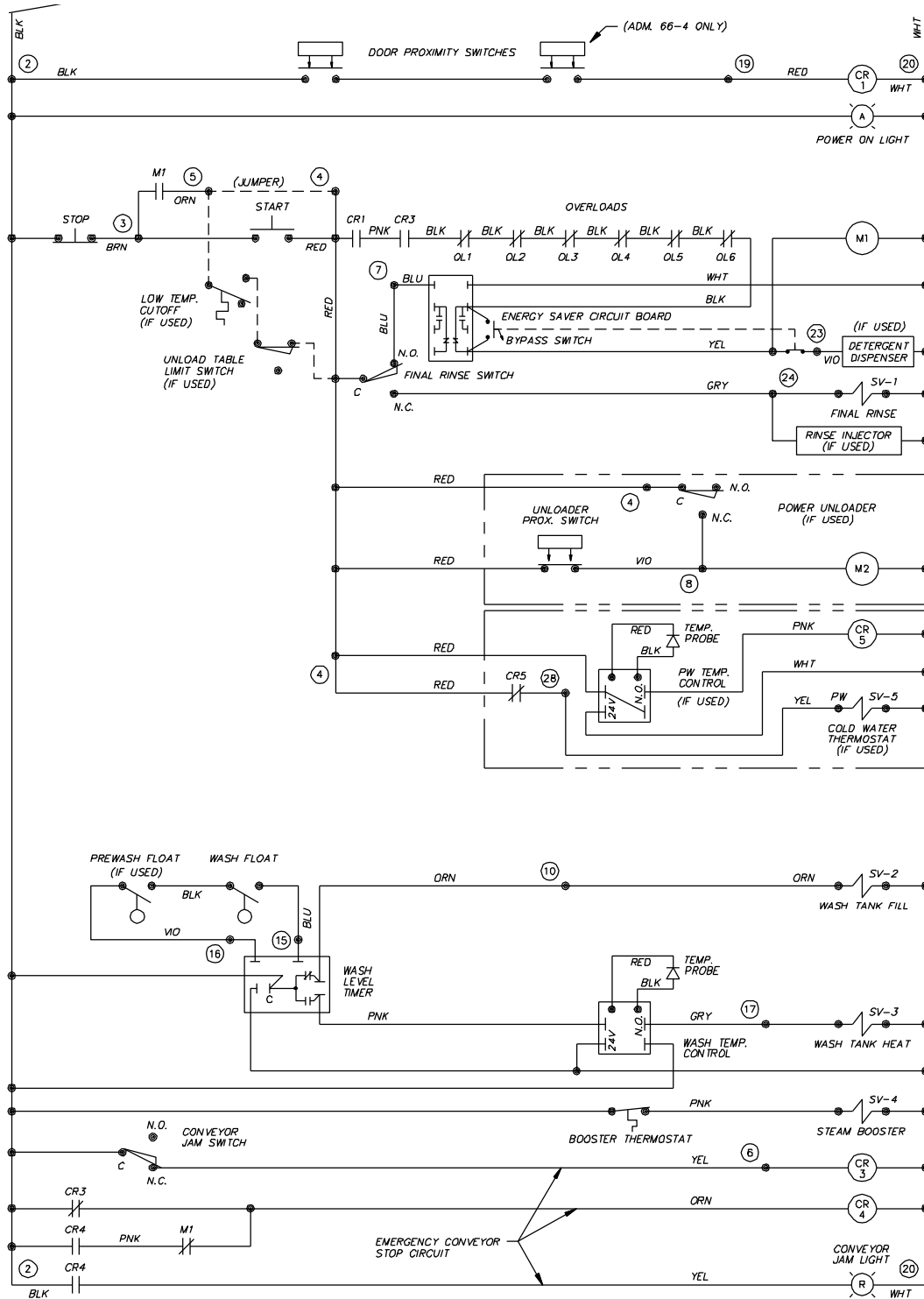

SHEET 2 OF 2

P	1752	4.11.00	TITLE	ADMIRAL 44-4, ADMIRAL 66-4	DWG. NO.	WADM010
N	1701	8.12.99		STEAM HEAT		
M	1583	12.1.97				
REV	ECN NO	DATE	Philadelphia, PA 19135 (215) 624-4800 FAX (215) 624-6966		DRWN/DATE	RAF
FILE:	WIRE\WADM010					04.10.95

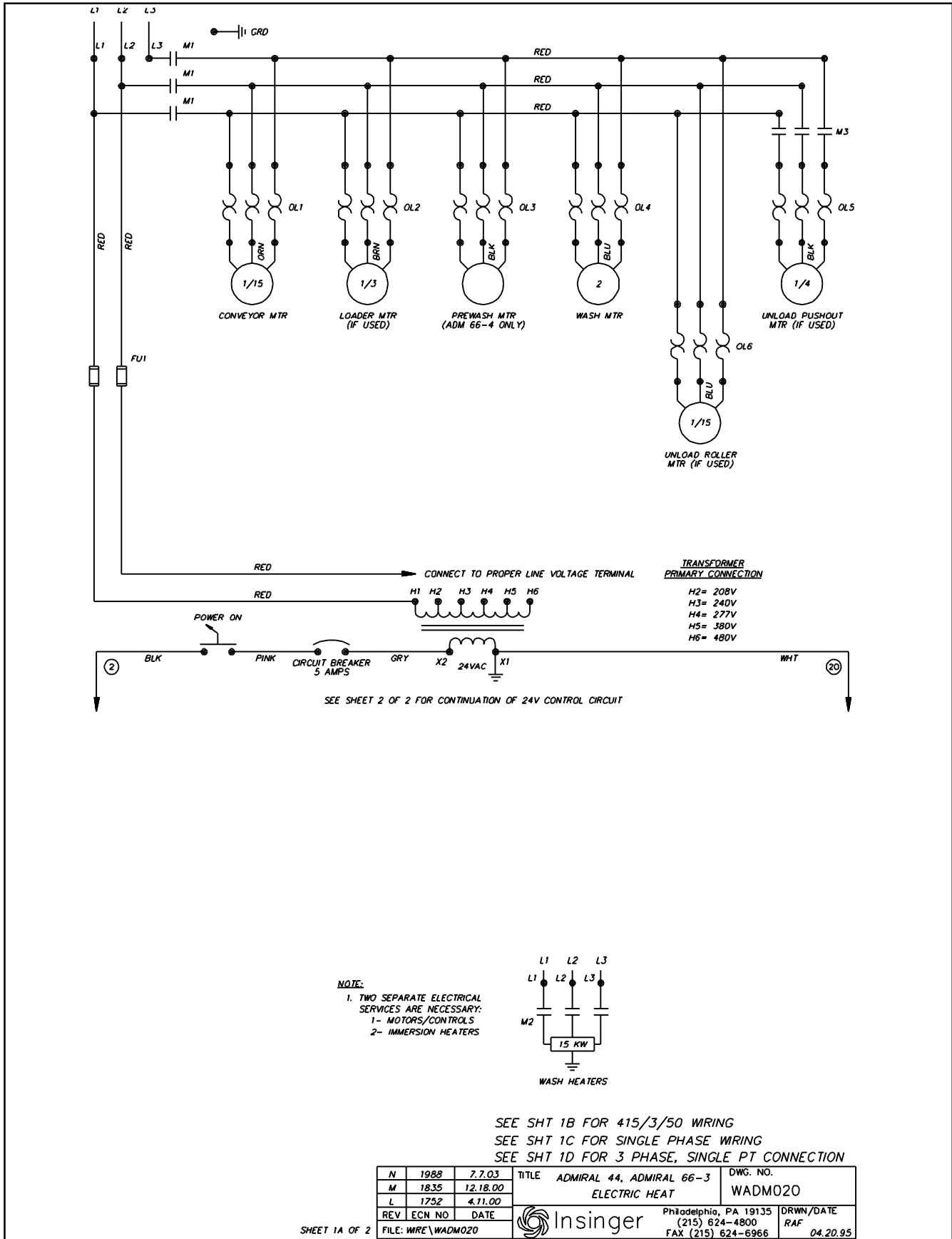

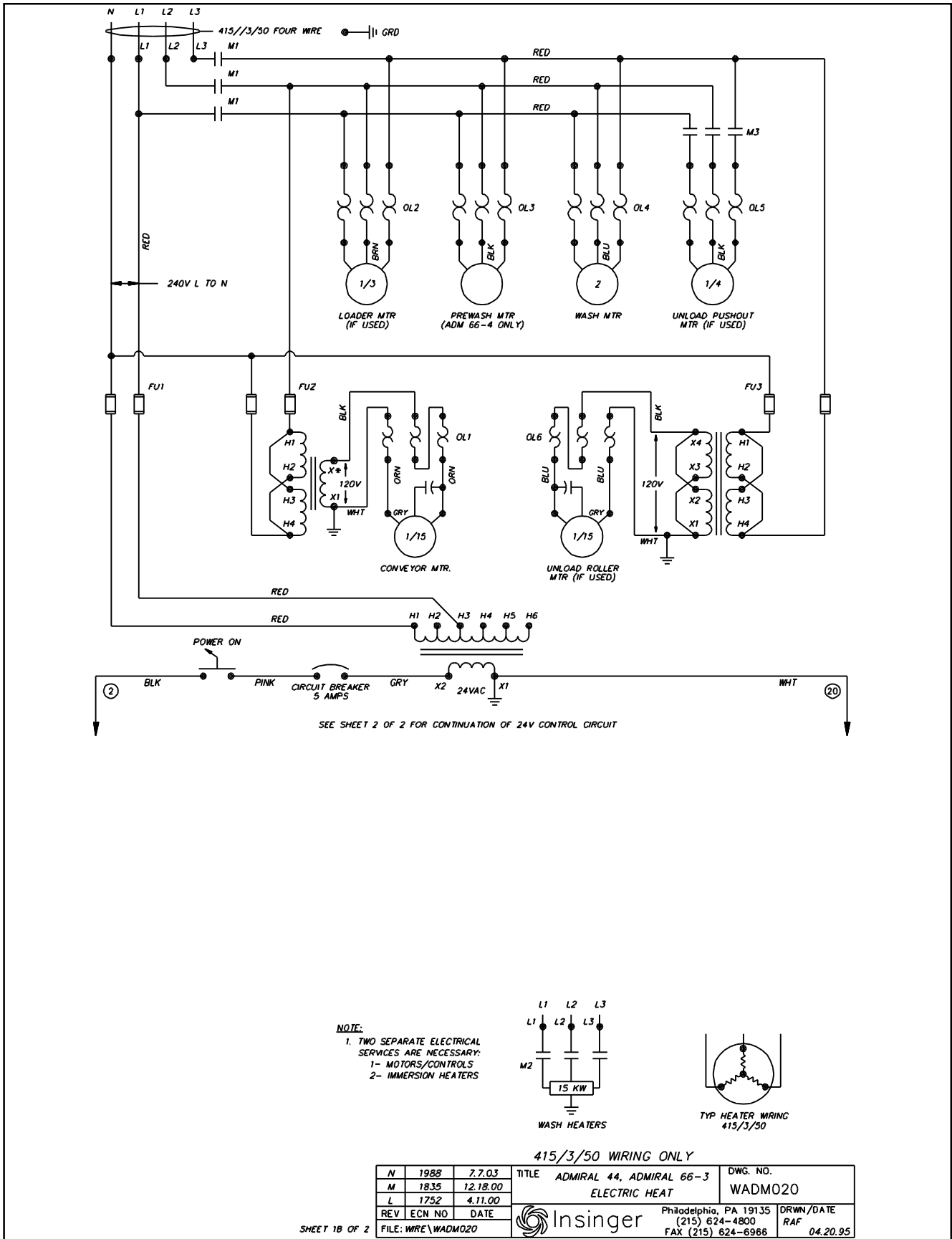

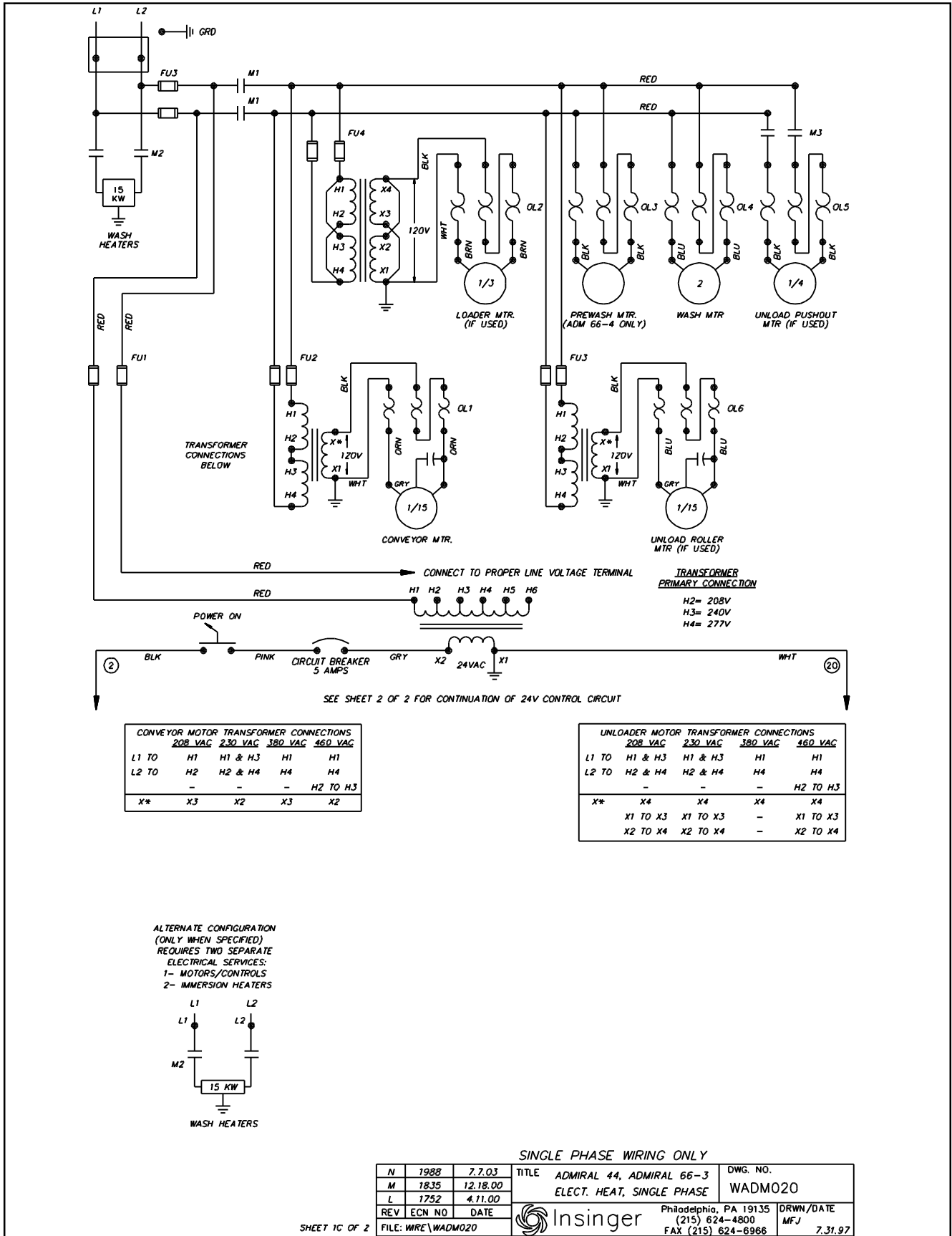

SINGLE PHASE WIRING ONLY

N	1988	7.7.03	TITLE	ADMIRAL 44, ADMIRAL 66-3	DWG. NO.	WADM020
M	1835	12.18.00		ELECT. HEAT, SINGLE PHASE		
L	1752	4.11.00				
REV	ECN NO	DATE				
FILE: WRE\WADM020			Philadelphia, PA 19135 (215) 624-4800 FAX (215) 624-6966		DRWN/DATE	MFJ 7.31.97

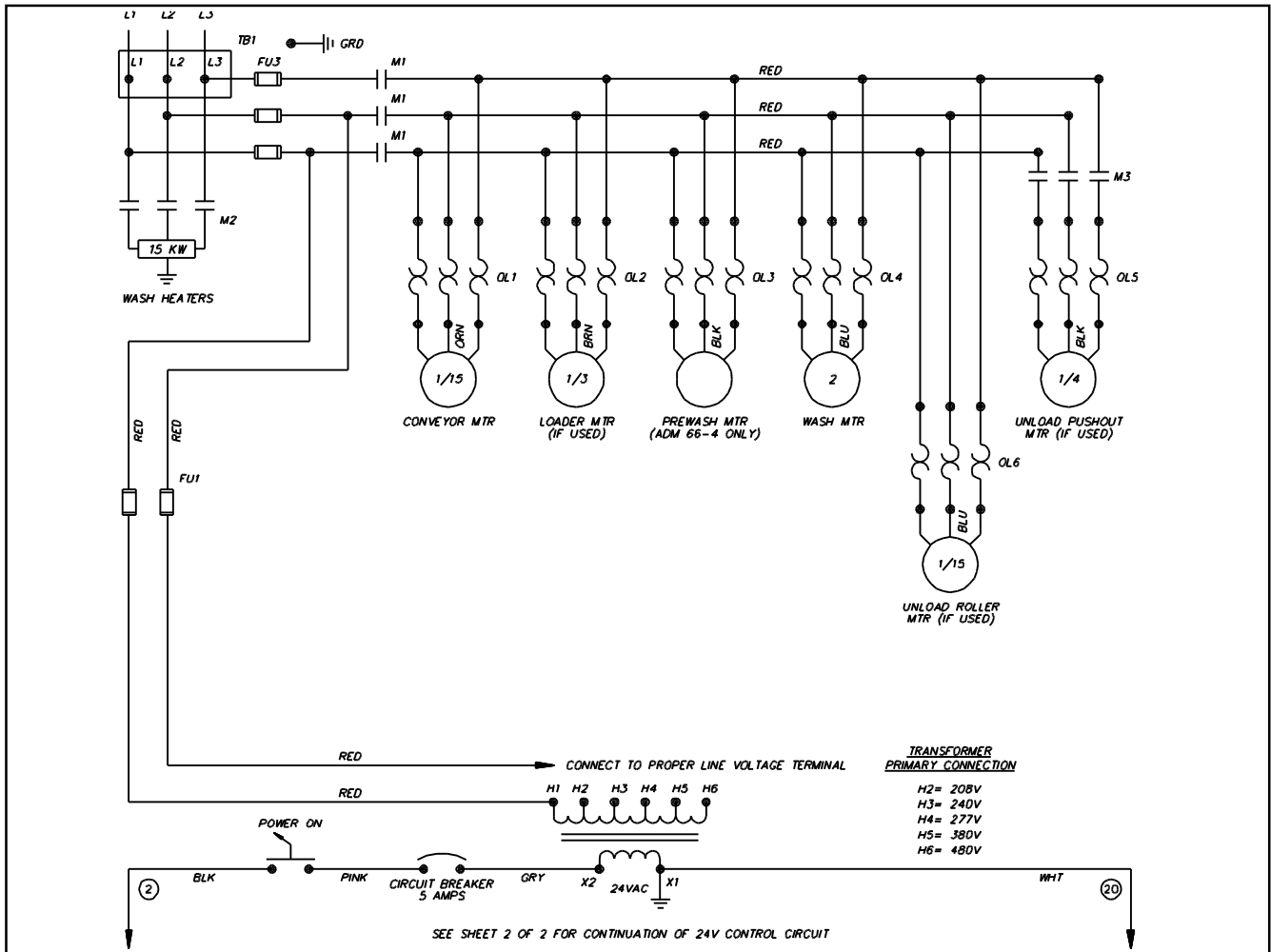

SEE SHEET 2 OF 2 FOR CONTINUATION OF 24V CONTROL CIRCUIT

SINGLE PT CONNECTION ONLY

N	1988	7.7.03	TITLE	ADMIRAL 44, ADMIRAL 66-3	DWG. NO.
M	1835	12.18.00		ELECTRIC W/SINGLE PT. CONN.	WADMO20
L	1752	4.11.00			
REV	ECN NO	DATE	Philadelphia, PA 19135 (215) 624-4800 FAX (215) 624-6966		DRWN/DATE
			FILE: WIRE\WADMO20		RAF 04.21.95

SHEET 10 OF 2

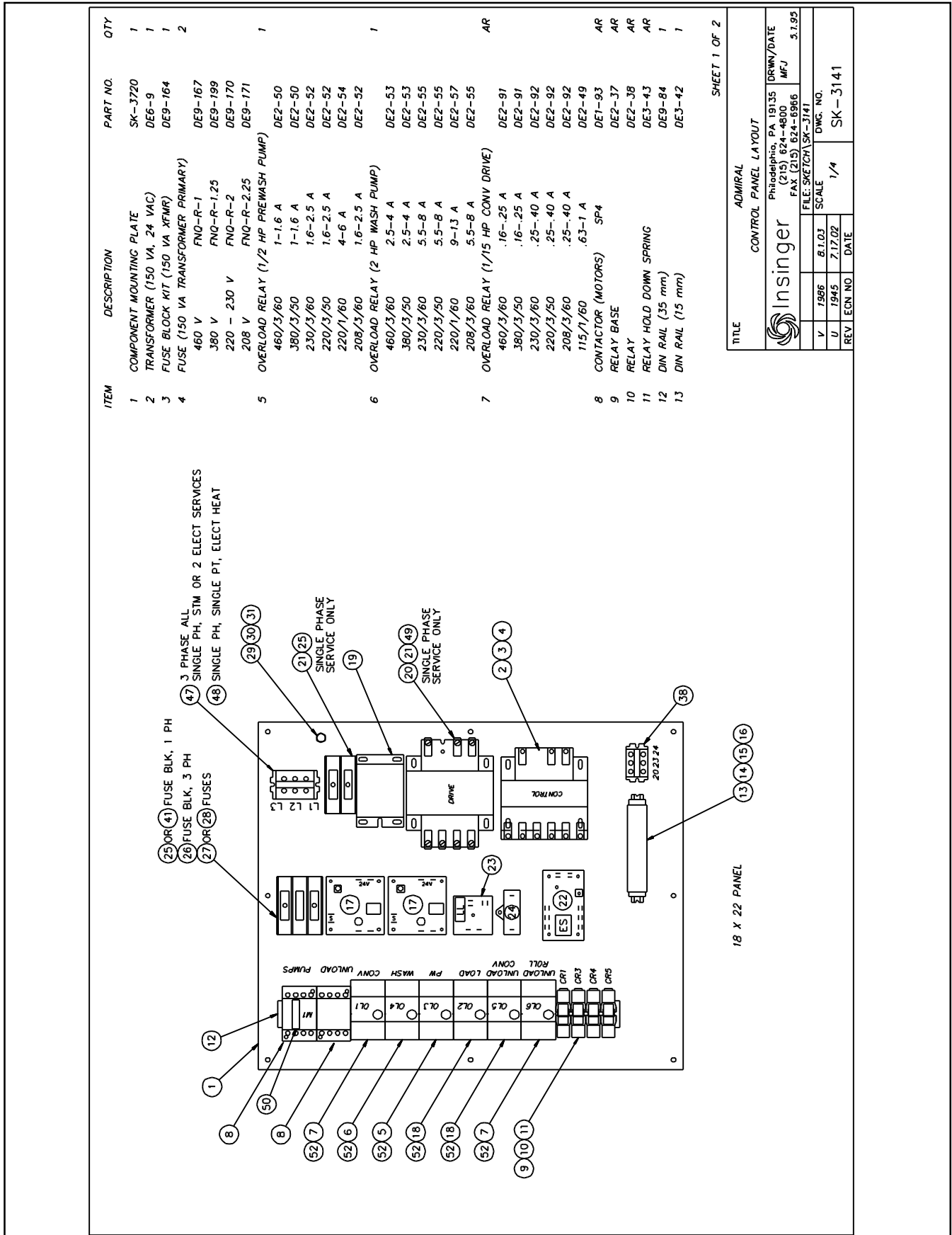

ITEM	DESCRIPTION	PART NO.	QTY
1	COMPONENT MOUNTING PLATE	SK-3720	1
2	TRANSFORMER (150 VA, 24 VAC)	DE6-9	1
3	FUSE BLOCK KIT (150 VA XFMR)	DE9-164	1
4	FUSE (150 VA TRANSFORMER PRIMARY)	DE9-167	2
	460 V	FNO-R-1	
	380 V	FNO-R-2	
	220 - 230 V	FNO-R-1.25	
	208 V	FNO-R-2.25	
5	OVERLOAD RELAY (1/2 HP PREWASH PUMP)	DE9-170	1
	460/3/60	DE9-171	
	1-1.6 A	DE2-50	
	380/3/50	DE2-50	
	1-1.6 A	DE2-50	
	230/3/60	DE2-52	
	1.6-2.5 A	DE2-52	
	220/3/50	DE2-52	
	1.6-2.5 A	DE2-54	
	220/1/60	DE2-54	
	4-6 A	DE2-52	
	208/3/60	DE2-52	
	1.6-2.5 A	DE2-53	
6	OVERLOAD RELAY (2 HP WASH PUMP)	DE2-53	1
	460/3/60	DE2-53	
	2.5-4 A	DE2-53	
	380/3/50	DE2-53	
	2.5-4 A	DE2-53	
	230/3/60	DE2-55	
	5.5-8 A	DE2-55	
	220/3/50	DE2-55	
	5.5-8 A	DE2-57	
	220/1/60	DE2-57	
	9-13 A	DE2-55	
	208/3/60	DE2-55	
	5.5-8 A	DE2-55	
7	OVERLOAD RELAY (1/15 HP CONV DRIVE)	DE2-91	AR
	460/3/60	DE2-91	
	.16-.25 A	DE2-91	
	380/3/50	DE2-91	
	.16-.25 A	DE2-91	
	230/3/60	DE2-92	
	.25-.40 A	DE2-92	
	220/3/50	DE2-92	
	.25-.40 A	DE2-92	
	208/3/60	DE2-92	
	.25-.40 A	DE2-92	
	115/1/60	DE2-49	
	.63-1 A	DE1-93	AR
8	CONTACTOR (MOTORS)	DE2-37	AR
	SP4	DE2-37	
9	RELAY BASE	DE2-38	AR
10	RELAY	DE3-43	AR
11	RELAY HOLD DOWN SPRING	DE9-84	1
12	DIN RAIL (.35 mm)	DE3-42	1
13	DIN RAIL (.15 mm)	DE3-42	1

TITLE ADMIRAL CONTROL PANEL LAYOUT

Philadelphia, PA 19135 DRWN/DATE
 (215) 372-4800 MFJ 5.1.95
 FAX (215) 624-0906
 FILE: SKETCH\SP-3141

SCALE 1/4 DWG. NO. SK-3141

REV ECN NO DATE

V 1996 8.1.03
 U 1945 7.17.02

SHEET 1 OF 2

RECOMMENDED ADMIRAL SERIES SPARE PARTS LIST

Part Number	Quantity	Description
Mechanical Parts		
32-541	1	Suction Strainer
D2242	1	Vacuum Breaker Repair Kit
D2-554-3	4	End Plug
D2-554-2	4	End Plug
D2498	3	Spray Nozzle, FR
D2700	3	Spray Nozzle, FR
D2390	1	Temperature Gauge– Wash
UP15	1	Seal, Pump
954-30K	1	Drain Assembly
D2-104	1	Shaft Bearings
D2-761	1	O-ring, Manifold
D2495	1	Temperature Gauge– FR
D2930RK	1	Solenoid Valve Repair Kit, 1/2" Water
Electrical Components		
DE3-68	1	Timer
DE7-33	1	Timer, Level
DE5-60	1	Level Float
DE9-251	1	Temperature Control Board
DE1-93	1	Magnetic Switch
DE9-252	1	Switch
For Electric Tank Heat Add:		
DE13-SE73		Immersion Heater
For Steam Tank Heat Add:		
D2946		Kit, 3/4" Steam

ITEM#	PART#	DESCRIPTION	REQ.	ITEM#	PART#	DESCRIPTION	REQ.
1	**	PUMP & MOTOR, WASH	1	31	D2606	SOLENOID VALVE	2
2	D2762	GEAR MOTOR	1	31A	D2641	SOLENOID VALVE REPAIR KIT	2
3	**	MOTOR	1	32	1089-189	FLOAT SWITCH ASSEMBLY	1
4	1397-1	DRIVE MECHANISM ASSEMBLY (SEE PARTS LIST)	1	33	D2857	DRIVEN SPROCKET	1
5	1169-60	DRAIN ASSEMBLY (SEE PARTS LIST)	1	34	512-207A	DRIVE SPROCKET	1
6	D2-554-3	PIPE PLUG 7/8-9UNC-2A	2	35	9014-TAB	CONVEYOR CHAIN	1
7	D2-554-2	PIPE PLUG 3/4-10UNC-2A	8	36	1183-12	FRONT TRACK	1
8	D514	DISCHARGE GASKET	1	37	1169-25	REAR TRACK ASSEMBLY (SEE PARTS LIST)	1
9	D530	SUCTION GASKET	1	38	1183-9	TRACK BRACKET	3
10	1162-110	BEARING BRACKET FRONT & REAR	2	39	1183-48	SCRAP SCREEN SPACER	1
11	1162-16	CONVEYOR DRIVE SHAFT	1	40	1472-18A	SPRAY PIPE FINAL RINSE - LOWER	1
12	D2099	DOOR HANDLE	1	41	1169-159	CHAIN TENSIONER ASSEMBLY (SEE PARTS LIST)	1
13	DE5-37	MAGNETIC SWITCH	1	42	1169-53	MANIFOLD ASSEMBLY - UPPER	1
14	D2914	VACUUM BREAKER 1/2	2	43	1169-54	MANIFOLD ASSEMBLY - LOWER	1
15	D2914RK	VACUUM BREAKER REPAIR KIT 1/2	2	44	1169-45	FINAL RINSE-INSIDE PIPING (STANDARD)	1
16	D2856	SPRAY NOZZLE - UPPER	3	45	1169-43	FINAL RINSE-INSIDE PIPING (CHEMICAL SANITIZER)	1
17	1472-19A	SPRAY PIPE FINAL RINSE - UPPER	1	46	1169-145	FINAL RINSE - LEVER ASSEMBLY	1
18	D2339	BALL VALVE 1/2	1	46	D2390	THERMOMETER	1
19	D2349	LATCH ASSEMBLY (SPRAY PIPE)	1	47	1169-62	CONTROL BOX & CHANNEL	1
20	D2406	ADJUSTABLE FOOT	1	48	1162-60	MECHANISM GUARD	1
21	D3-528	CURTAIN - EXIT	4	49	1169-165	CONVEYOR FOLLOWER SHAFT	1
22	D3-525	CURTAIN - ENTER	1	50	D3-849	STOP BRACKET, UPPER MANIFOLD	1
23	D3-508	CURTAIN - CENTER	1	51	D2-564	O-RING, MANIFOLD	2
24	1472-22	DOOR	1	52	1182-29	SCRAP SCREEN	2
25	D2715-R	DOOR LATCH, RIGHT	2	53	D2853	SPRAY NOZZLE - LOWER	4
26	D2715-L	DOOR LATCH, LEFT	2	54	816-58	SPRING	1
27	1169-40	PRESSURE GAUGE	1	55	DE5-4	SWITCH, FINAL RINSE	1
28	1162-31	DISCHARGE TUBE ASSEMBLY (SEE PARTS LIST)	1	56	828-52	BRACKET, PIPING	1
29	D2-541	STATIONARY STOP	1	57	D2495	THERMOMETER, FINAL RINSE	1
30	D2858	SUCTION STRAINER	1	58	1169-56	TOP BAFFLE INSTALLATION	1
		HUB SPACER	1	59	SK-3700	LABEL LOCATION	1
			1	60	D3-550	CURTAIN - VESTIBULE	2

SHEET 2 OF 2

NEXT ASSY/DWG. NO.		PARTS LIST	
REQ'D	NOTED	ADMIRAL 44-4	
SCALE	FULL	NOTED	
USED ON	ADM 44-4		
Philadelphia, PA 19135 (215) 624-4800 FAX (215) 624-8966			

** = MUST SPECIFY SERIAL NO. OF MACHINE

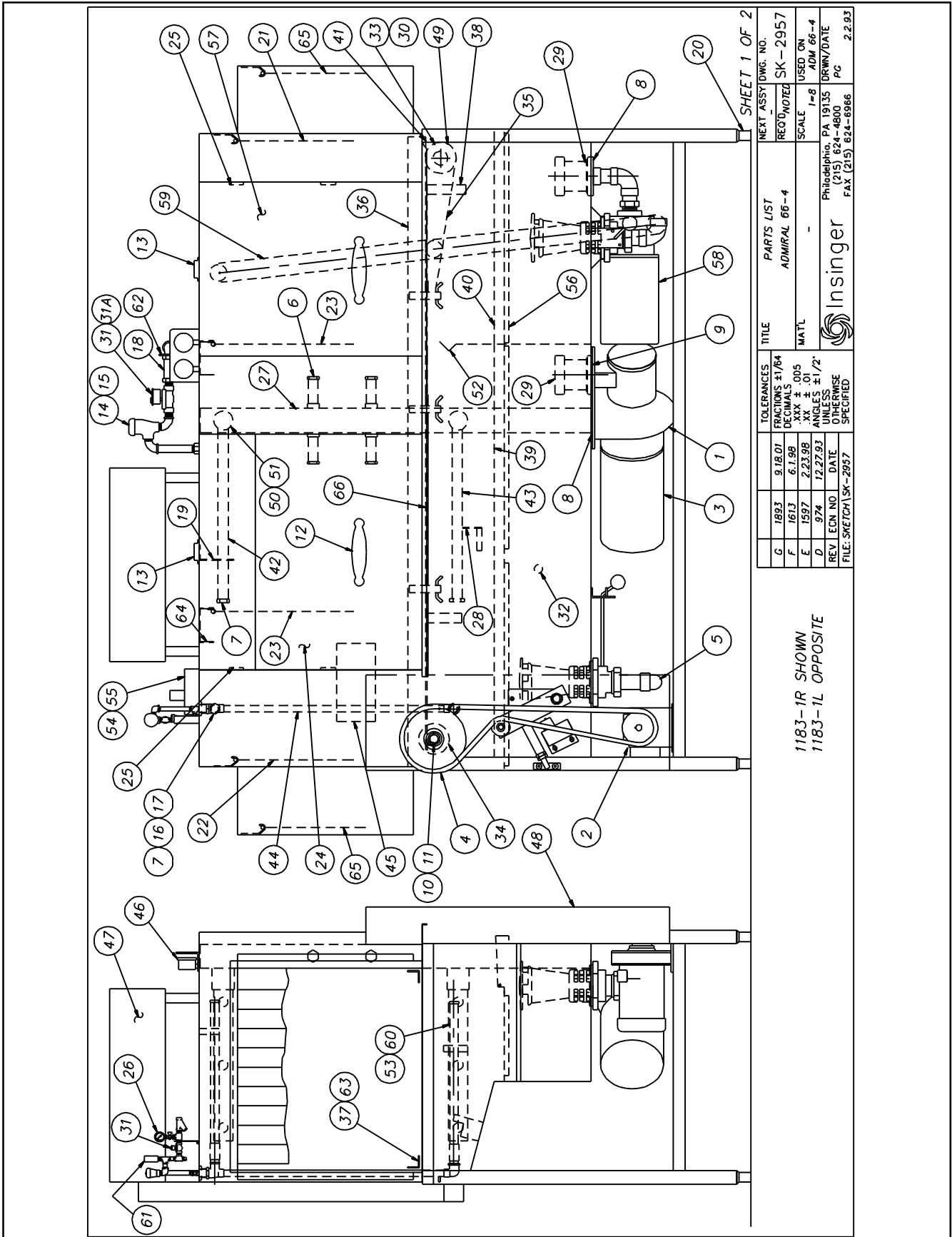

SHEET 1 OF 2

NEXT ASSY/DWG. NO.		SK-2957	
RECD/NOTED		ADMIRAL 66-4	
SCALE		1-8	
USED ON		ADM 66-4	
DRWN/DATE		PC	
FILE: SKETCH/ SK-2957		2.2.93	

TOLERANCES	FRACTIONS ±1/64
	DECIMALS .005
	ANGLES ±1/2°
	UNLESS OTHERWISE SPECIFIED

TITLE	PARTS LIST
ADMIRAL 66-4	
MAT'L	

1183-1R SHOWN
1183-1L OPPOSITE

Insinger
Philadelphia, PA 19135
(215) 624-4800
FAX (215) 624-6966

ITEM#	PART#	DESCRIPTION	REQ.	ITEM#	PART#	DESCRIPTION	REQ.
1	**	PUMP & MOTOR, WASH	1	32	1089-189	FLOAT SWITCH ASSEMBLY	1
2	D2762	GEAR MOTOR	1	33	512-206A	DRIVEN SPROCKET	1
3	**	MOTOR	1	34	512-207A	DRIVE SPROCKET	1
4	1397-1	DRAIN MECHANISM ASSEMBLY (SEE PARTS LIST)	1	35	9014-010	CONVEYOR CHAIN	1
5	1169-60	DRAIN ASSEMBLY (SEE PARTS LIST)	2	36	1183-12	FRONT TRACK	1
6	D2-554-3	PIPE PLUG 7/8-9UNC-2A	4	37	1460-11	REAR TRACK ASSEMBLY (SEE PARTS LIST)	1
7	D2-554-2	PIPE PLUG 3/4-10UNC-2A	10	38	1440-10	TRACK BRACKET - FRONT	3
8	D514	DISCHARGE GASKET	2	39	1183-48	SCRAP SCREEN SPACER - WASH	1
9	D530	SUCTION GASKET	1	40	1182-28	SCRAP SCREEN SPACER - PREWASH	1
10	1162-110	BEARING BRACKET	2	41	1169-159	CHAIN TENSIONER ASSEMBLY (SEE PARTS LIST)	1
11	1162-16	CONVEYOR DRIVE SHAFT	1	42	1169-53	MANIFOLD ASSEMBLY - UPPER	1
12	D2099	DOOR HANDLE	2	43	1169-54	MANIFOLD ASSEMBLY - LOWER	1
13	DE5-37	MAGNETIC SWITCH	2	44	1169-45	FINAL RINSE - INSIDE PIPING	1
14	D2914	VACUUM BREAKER 1/2	2	45	1169-145	FINAL RINSE - LEVER ASSEMBLY	1
15	D2914RK	VACUUM BREAKER REPAIR KIT 1/2	2	46	D2390	THERMOMETER	2
16	D2856	SPRAY NOZZLE - UPPER	3	47	1183-23	CONTROL BOX & CHANNEL	2
17	1472-19A	SPRAY PIPE FINAL RINSE - UPPER	1	48	1162-60	MECHANISM GUARD	1
18	D2339	BALL VALVE 1/2	1	49	1169-165	CONVEYOR FOLLOWER SHAFT	1
19	D2349	LATCH ASSEMBLY (SPRAY PIPE)	1	50	D3-849	STOP BRACKET, UPPER MANIFOLD	1
20	D2406	ADJUSTABLE FOOT	4	51	D-580	O-RING, MANIFOLD	2
21	D3-527	CURTAIN - ENTER	1	52	1169-38R	TANK BAFFLE	1
22	D3-528	CURTAIN - EXIT	1	53	D2853	SPRAY NOZZLE - LOWER	4
23	D3-508	CURTAIN - CENTER	2	54	816-58	SPRING	1
24	1169-22	DOOR (WASH)	1	55	DE5-4	SWITCH, FINAL RINSE	1
25	D2715-R	DOOR LATCH, RIGHT	2	56	1182-29	SCRAP SCREEN	3
26	D2715-L	DOOR LATCH, LEFT	2	57	1460-14	DOOR (PREWASH)	1
27	SK-1433	PRESSURE GAUGE	1	58	**	MOTOR (PREWASH)	1
28	1183-50	DISCHARGE TUBE ASSEMBLY - WASH	1	59	1460-21	DISCHARGE LINE ASSEMBLY - PREWASH	1
29	1162-31	STATIONARY STOP	1	60	1472-18A	SPRAY PIPE FINAL RINSE - LOWER	1
30	D2-541	SUCTION STRAINER	2	61	D2495	THERMOMETER, FINAL RINSE	1
31	D2858	HUB SPACER	1	62	828-52	BRACKET, PIPING SUPPORT	1
31A	D2606	SOLENOID VALVE	2	63	1440-13	TRACK BRACKET - REAR	3
	D2641	SOLENOID VALVE REPAIR KIT	2	64	1183-21	TOP BAFFLE INSTALLATION	1
				65	D3-550	CURTAIN - VESTIBULE	2
				66	1440-13	TRACK BRACKET - REAR	3



** = MUST SPECIFY SERIAL NO. OF MACHINE

SHEET 2 OF 2

TOLERANCES	TITLE	PARTS LIST	NEXT ASSY/DWG. NO.
FRACTIONS ±1/84	ADMIRAL 66-4	ADMIRAL 66-4	REC'D - SK-2957
DECIMALS ±.005	MATL	NOTED	SCALE USED ON
XXX ±.01			FULL ADM 66-4
ANGLES ±1/2°			UNLESS OTHERWISE SPECIFIED
UNLESS OTHERWISE SPECIFIED			
REV ECN NO DATE	Insinger		Philadelphia, PA 19135
G 1893 9.18.01			(215) 624-4800
FILE: SKETCH/ASK-2957			FAX (215) 624-6966
			10.18.93

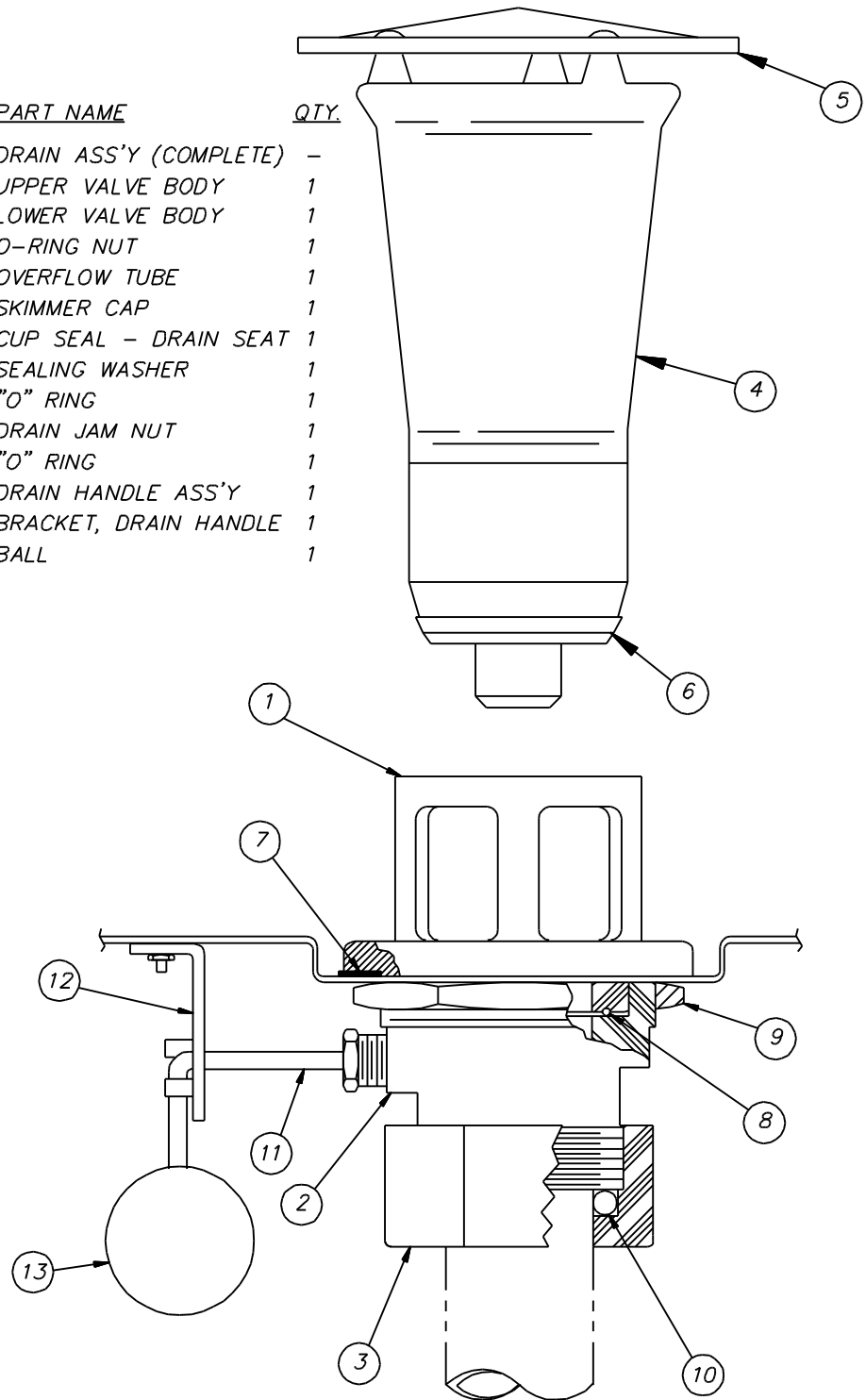
<u>ITEM</u>	<u>PART NO.</u>	<u>PART NAME</u>	<u>QTY.</u>
	954-50	DRAIN ASS'Y (COMPLETE)	-
1	954-50A	UPPER VALVE BODY	1
2	954-50B	LOWER VALVE BODY	1
3	954-50C	O-RING NUT	1
4	1169-179D	OVERFLOW TUBE	1
5	D193	SKIMMER CAP	1
6	D2-557	CUP SEAL - DRAIN SEAT	1
7	954-9	SEALING WASHER	1
8	D2-549	"O" RING	1
9	D305A	DRAIN JAM NUT	1
10	D2-550	"O" RING	1
11	1100-79A	DRAIN HANDLE ASS'Y	1
12	954-8C	BRACKET, DRAIN HANDLE	1
13	D2-507	BALL	1



-  ECN# 1989 7.7.03
-  ECN# 1761 5.5.00
-  ECN# 1512 12.20.96

FILE: SKETCHA\SK-3028

MAM 2.11.93

SK-3028

Insinger

 Philadelphia, PA 19135
 (215) 624-4800
 FAX (215) 624-6966

ITEM	PART NO.	DESCRIPTION	QTY.
1		MOTOR 1/2 H.P.	1
2	D431	ADAPTER	1
3	D432	IMPELLER 3"	1
4	D434	CASING	1
5	D2-532	"O" RING	1
6	D2-533	FLINGER	1
7	D2-534	SEAL ASSEMBLY	1
8		DRAIN PLUG 1/4 IPS	1
9	D3-808	IMPELLER RETAINING NUT	1

* - 3 PHASE MOTORS ONLY

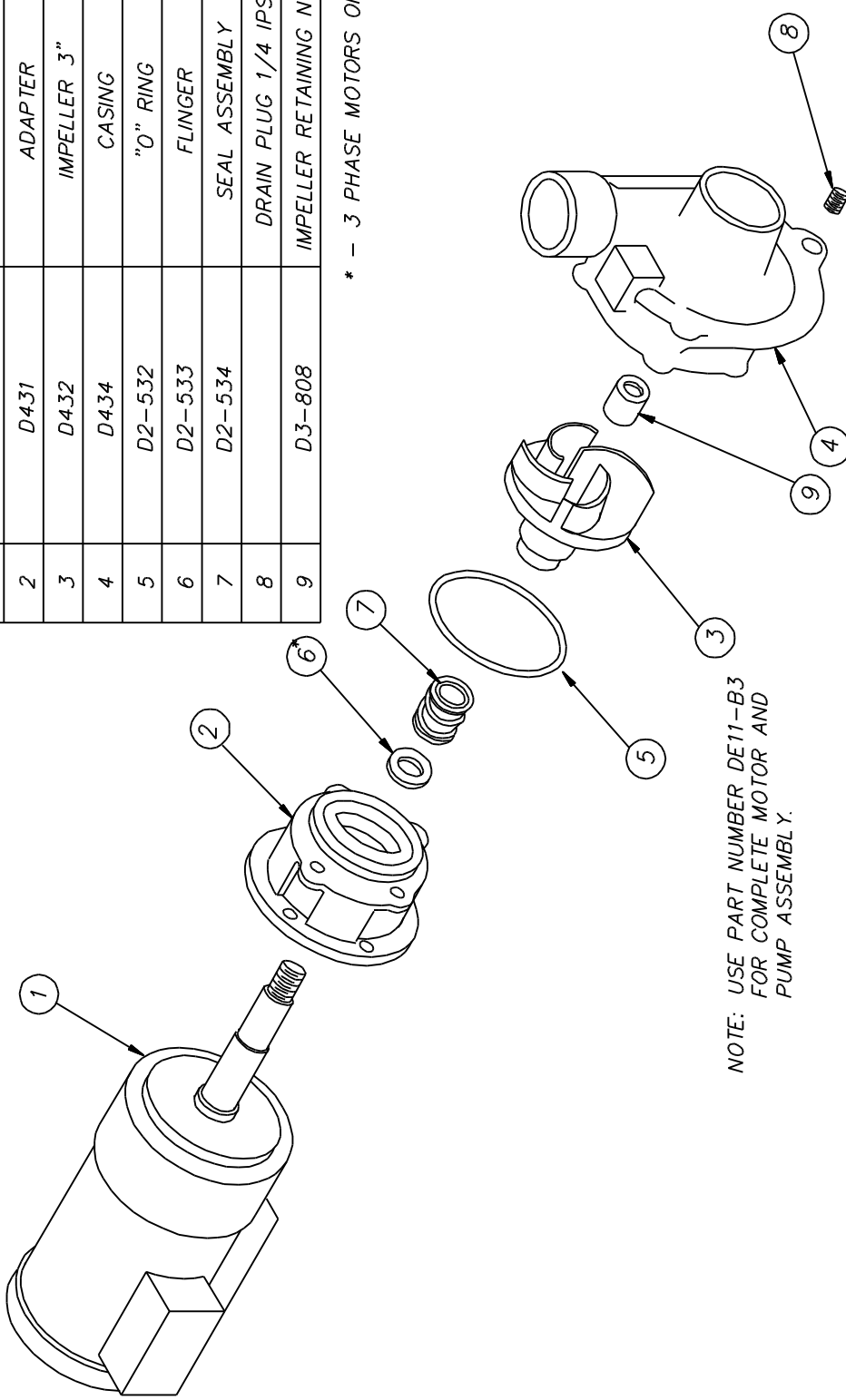

NOTE: USE PART NUMBER DE11-B3 FOR COMPLETE MOTOR AND PUMP ASSEMBLY.

	TOLERANCES	NEXT ASSY DWG. NO.	REQ'D	SCALE	USED ON
	FRACTIONS ±1/64		-	-	VARIOUS
	DECIMALS				
B	.XXX ± .005				
A	.XX ± .01				
REV	ECN NO	DATE			
	FILE: SKETCHA \ SK-2397				
 Insinger		Philadelphia, PA 19135 (215) 624-4800 FAX (215) 624-6966		DRWN/DATE MAM 11.11.93	

ITEM	PART NO.	DESCRIPTION	QTY.
1	UP-1	PUMP BODY	1
2	D-435	ADAPTER	1
3	NOTED	IMPELLER	1
4	SUP-3	END COVER PLATE	1
5	D3-805	PUMP SHAFT	1
6	D3-816	HOUSING COVER GASKET	1
7		FLINGER	1
8	UP-8	END COVER GASKET	1
9	UP-9	HOUSING COVER GASKET	1
10	UP-13	CERAMIC SEAL	1
11	UP-15	END COVER BOLT	12
12	D309C-JC-6A	KEY	1
13		WASHER	1
14	D302-1	LOCKWASHER	1
15	D3-824A	IMPELLER BOLT	1
16	D313C-J2	WASHER	12
17	D309C-JC-5A	SET SCREW	2
18	D313A-J1		
19			
20	D309C-GC-2H		

NOTE: FOR COMPLETE ASSEMBLY USE PART NO. D2471A
 IMPELLER PART NO. & SIZE:
 SUP-2A 4 1/2" (MODULAR SPEEDER SUPER W & R)
 SUP-3A 5" (ADMIRAL WASH, CLIPPER/MASTER/CENTURY PW)

TOLERANCES	TITLE	NEXT ASSY/DWG. NO.
FRACTIONS ±1/64	PUMP ASSEMBLY	RECD 1 SK-2456A
DECIMALS .XXX ± .005	MODEL 2 1/2 SUP	SCALE FULL USED ON
.XX ± .01	MATL	
ANGLES ± .1/2°		
OTHERWISE SPECIFIED		
REV A	965	11.12.93
ECN NO.		DATE
FILE: SKETCH\SK-2456A		

Insinger Philadelphia, PA 19135 (DRWN/DATE)
 (215) 824-4800 (PC)
 FAX (215) 624-6966 8.28.94

ITEM	PART NO.	DESCRIPTION	QTY
1	1162-16	CONVEYOR DRIVE SHAFT (Rev F)	1
2	975-55	SPROCKET	1
3	D302-4	#11 WOODRUFF KEY S/S	2
4	D2-525	WASHER, NYLON (1 3/8 X 7/8 X 1/8)	2
5	D-311-1	COTTER PIN S/S 1/8 X 1 1/2	1
6	1162-110	BEARING BRACKET	2
7	D312C-HC-5	LOCKNUT 5/16-18	8
8	D2-565	"O" RING (O1-115)	1
9	D309C-CH-3H	SET SCREW S/S 5/16-18 X 3/8	1
10	D309C-HC-7A	HEX HD SCREW S/S 5/16-18 X 1 3/8	8
11	1528-5	RACK EJECTOR PADDLE	1
12	D313C-HI	WASHER, PLAIN 5/16	8
13	D309C-GC-22A	HEX HD SCREW S/S 1/4-20 X 2 3/4	1
14	D312C-GC-5	LOCKNUT 1/4-20	1

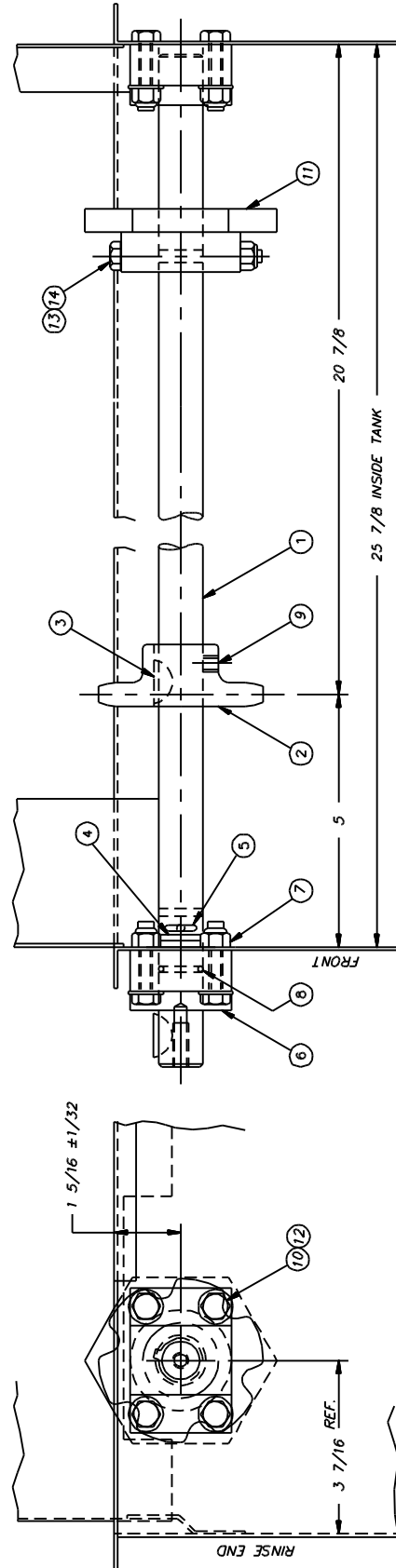

RH SHOWN - LH OPPOSITE

TOLERANCES		TITLE		NEXT ASSY DWG. NO.	
D	1996	9.19.03	CONVEYOR DRIVE	REQ'D/NDZED	1162-111
C	1905	11.08.01	SHAFT ASSEMBLY	SCALE	USED ON
B	1763	8.1.00	MATL	1/2	ADM/SPDR
A	1591	7.28.99	NOTED	1/2	DRWN/DATE
REV	ECN NO	DATE	Philadelphia, PA 19135		
			(215) 624-4800		
			PC		
			FILE: PARTS\1162-111		

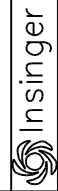

Insinger
 (215) 624-4800
 FAX (215) 624-6966

SECTION A-A FULL SIZE

NOTES:

1. THESE DIMENSIONS LOCATE THE CENTERS OF (2) 9/16 DIA HOLES TO BE DRILLED THRU SIDE OF MACHINE.
2. SEE SK-3875 FOR RETRO-FIT
3. BE SURE SPROCKET IS ALIGNED WITH TRACK BEFORE INSTALLING CHAIN. RE-POSITION WASHERS (ITEM #14) IF NECESSARY.

USED ON:
ADMIRAL 44 & 66-3
SPEEDER 64 & 86-3

R.H. SHOWN, L.H. OPPOSITE

ITEM	PART NO.	DESCRIPTION	QTY.
1	1169-160	FRAME (5/8 DIA HOLES)	1
2	1169-199	YOKE (SHEET METAL)	1
3	1169-162	ADJUSTMENT SCREW	2
4	D3-549	RUBBER GROMMET 5/16 ID	2
5	D313C-H1	FLAT WASHER 5/16	4
6	1169-189	SHAFT	1
7	-	-	-
8	D309C-EF-4G	WELD STUD #10-32 x 1/2	2
9	D312C-EF-5	SEAL NUT #10-32	3
10	D312C-HC-2	HEX NUT 5/16-18	4
11	D2857	SPROCKET (UHMW)	1
12	D2858	HUB SPACER 1 1/16 LG	1
13	-	-	-
14	D2-525	WASHER	3
15	D309C-EF-6C	WELDSTUD #10-32 x 3/4	1

TOLERANCES		NEXT ASSY DWG. NO.	
F	1/64	5.31.00	1169-159
E	1/32	9.18.97	RECD 1
D	1/64	6.6.96	SCALE 1:2
C	1/32	2.19.96	USED ON
REV	ECN NO.	DATE	SEE ABOVE
FILE	PARTS\1169-159		DRWN/DATE
			MAM 11.11.94

Insinger

Philadelphia PA 19135
(215) 824-4800
FAX (215) 624-6966

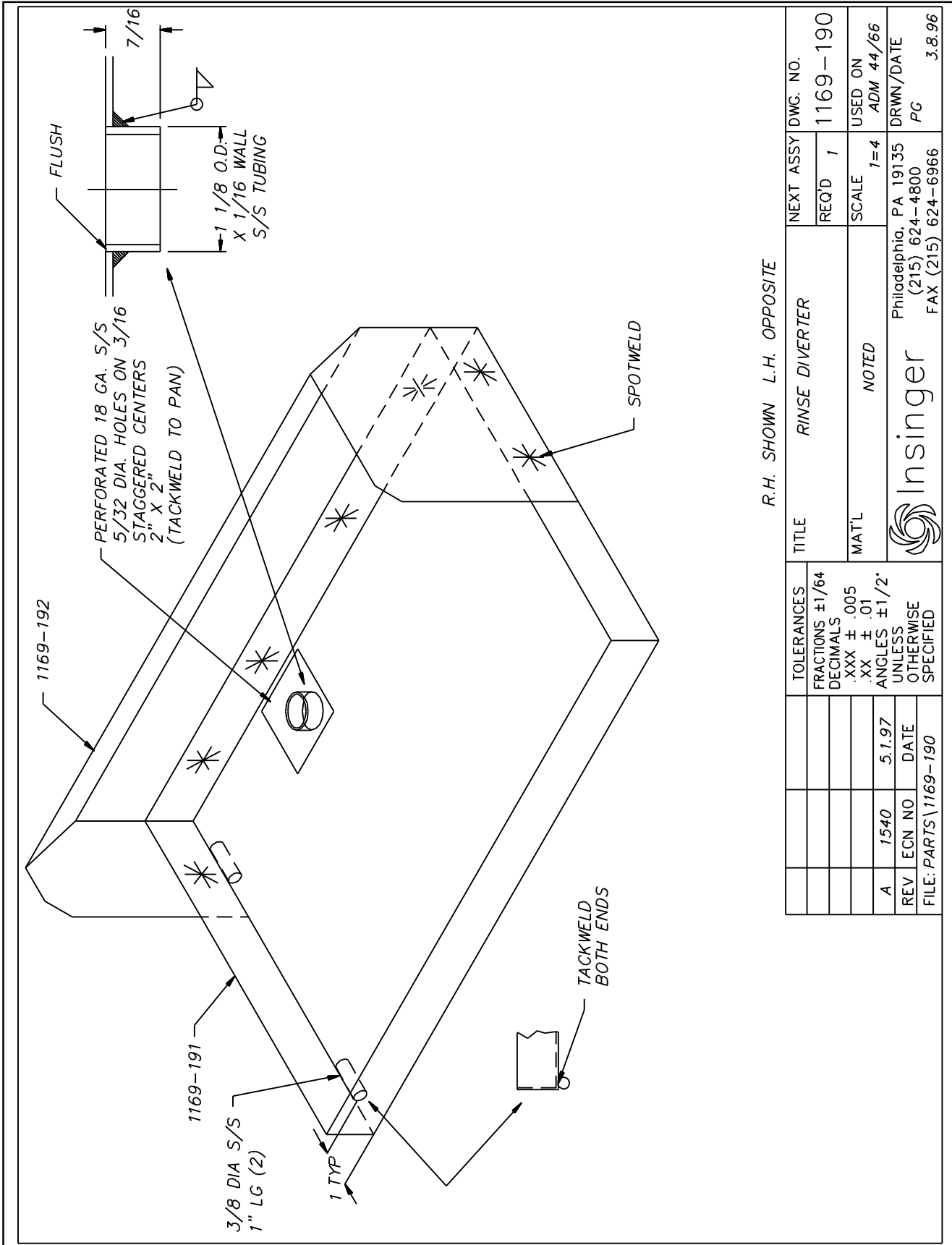

ITEM	PART NO.	DESCRIPTION	QTY.	ITEM	PART NO.	DESCRIPTION	QTY.
1	D2-158	TANK FLANGE	1	12	D313A-J1	WASHER-COPPER 3/8	3
2	1162-105R	DISCHARGE TUBE ASSY	1	13	D309C-JC-10A	HEX HD.SCR. 3/8-16 x 1 1/4	1
3	1169-96	SUPPORT INSTALLATION	1	14	D309C-JC-11A	HEX HD.SCR. 3/8-16 x 1 3/8	3
4	1169-53R	UPPER MANIFOLD ASSY	1	15	D312C-JC-5	LOCKWUT. 3/8-16	3
5	1169-54R	LOWER MANIFOLD ASSY	1	16			
6	1440-32	CAPTIVE END PLUG INSTALLATION	9	17			
7	D2935	SPRING PLUNGER PIN	2	18	1162-109	EXTENSION-WASH MANIFOLD (90°)	2
8	D-580	"O" RING (01-029)	2	19	D2773	SPRAY NOZZLE (80100)	2
9	D-514	GASKET	1	20			
10							
11	D3-511	CUPSEAL/PARKER #8406-0250-4180	1				

TOLERANCES	TITLE	DISCHARGE LINE	NETV ASSY/DWG. NO.
FRACTIONS ±1/64	ASSEMBLY - RH MACHINE		1169-40R
DECIMALS ±.005	MATL		REC'D 1
XXX ±.005			SCALE 1=8
ANGLES ±1/2°			USED ON ADM 44
UNLESS OTHERWISE SPECIFIED			DRWN/DATE PC

REV	ECN NO	DATE	FILE: PARTS\1169-40R
J	1983	6.3.03	

NOTES:
 1. END PLUG (INCLUDED IN ITEM 6)
 IS D2-554-2.

ITEM	PART NO.	DESCRIPTION	QTY.
1	1182-29	SCRAP SCREEN	2
2	1183-48L	SPACER, SCRAP SCREEN	1
3	D309C-OP-3G	WELDPIN 1/4 DIA X 3/8	10

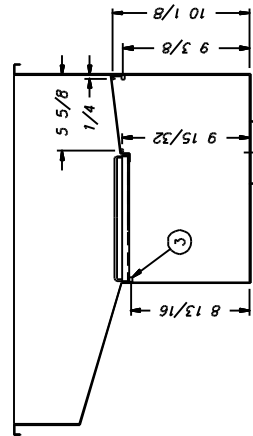
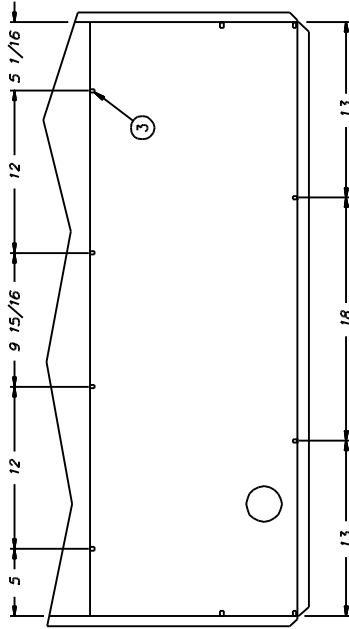

END WALLS & TANK DIVIDER

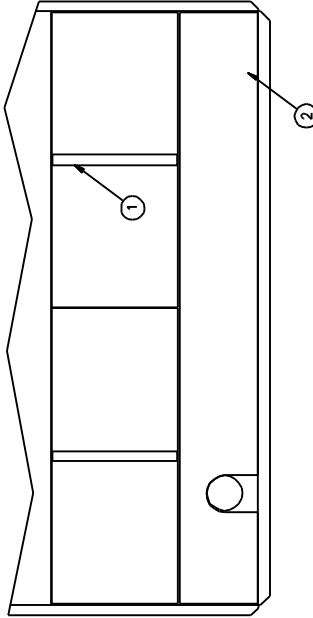

LEFT HAND MACHINE ONLY

TOLERANCES		TITLE		NEXT ASSY DWG. NO.	
FRACTIONS	±1/64	SCRAP SCREEN	REC'D	1	1169-12L
DECIMALS	.XXX ± .005	ARRANGEMENT	SCALE		USED ON
.XXX ± .01		MAT'L		1-8	ADM 44
ANGLES	±1/2°	AS NOTED			DRWN/DATE
UNLESS OTHERWISE SPECIFIED					PC
REV	ECN NO	DATE	Philadelphia, PA 19135 (215) 824-4800 FAX (215) 624-6986		
FILE: PARTS\1169-12L		12.2.92			

ITEM	PART NO.	DESCRIPTION	QTY.
1	1182-29	SCRAP SCREEN	3
2	1182-28	SPACER, SCRAP SCREEN	1
3	1183-48R	SPACER, SCRAP SCREEN	1
4	D309C-GP-3G	WELDPIV 1/4 DIA X 3/8	16

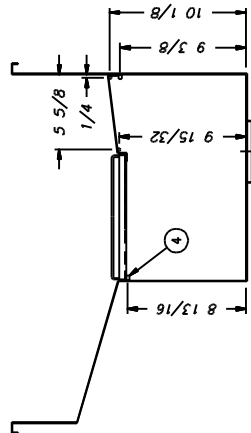
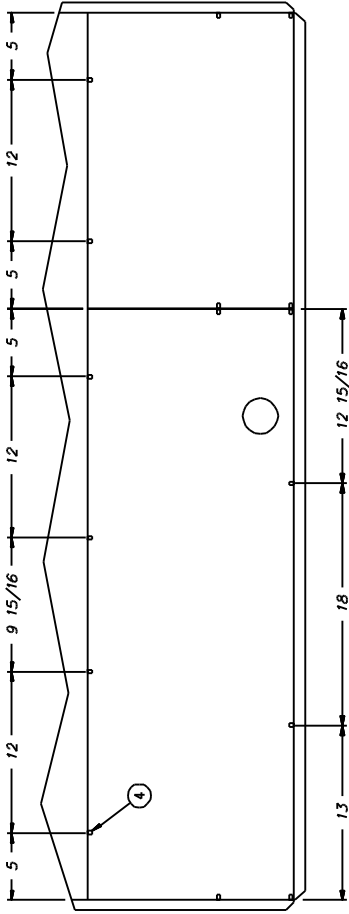

END WALLS & TANK DIVIDER

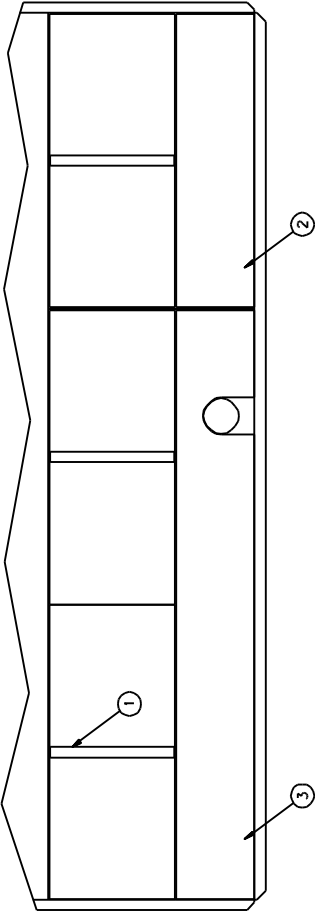

RIGHT HAND MACHINE ONLY

TOLERANCES		TITLE		NETF ASSY/DWG. NO.	
FRACTIONS ±1/64	DECIMALS ±	SCRAP SCREEN ARRANGEMENT	REC'D	1183-20R	1183-20R
XXX ± .005	XXX ± .005	MATL	1	USED ON	ADM66-J
ANGLES ±1/2°	UNLESS OTHERWISE SPECIFIED	AS NOTED	1=8	DRWN/DATE	PC
REV ECN NO DATE		Philadelphia, PA 19135 (215) 624-4800 FAX (215) 624-6966			
FILE: PARTS\1183-20R		17.19.92			

ITEM	PART NO.	DESCRIPTION	QTY.
1	1182-29	SCRAP SCREEN	3
2	1182-28	SPACER, SCRAP SCREEN	1
3	1183-48L	SPACER, SCRAP SCREEN	1
4	D309C-GP-3G	WELD PIN 1/4 DIA X 3/8	16

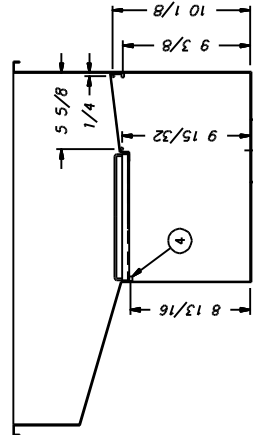
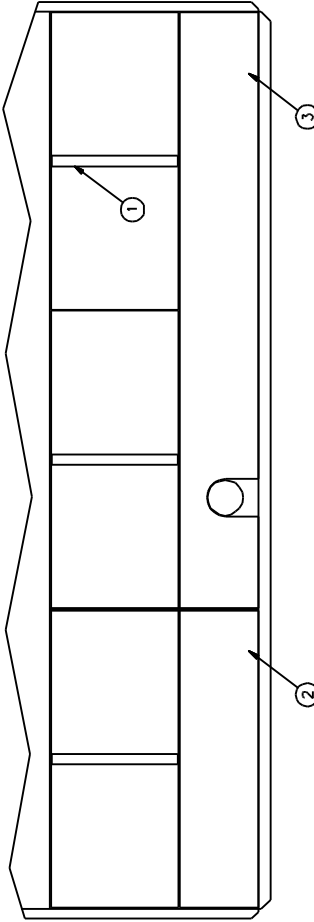
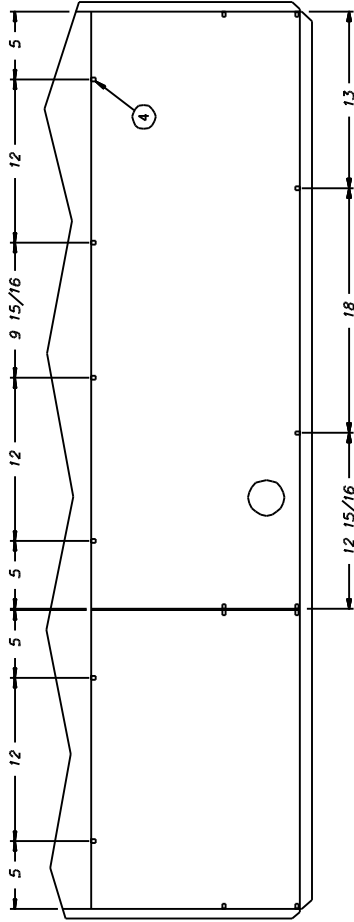

END WALLS & TANK DIVIDER

LEFT HAND MACHINE ONLY

TOLERANCES		TITLE		NEXT ASSY DWG. NO.	
FRACTIONS	±1/64	SCRAP SCREEN	ARRANGEMENT	7183-7	1183-20L
D	1556	6.10.97	MAT'L	RECD	1
C	605	2.8.93	AS NOTED	SCALE	1=8
B	783	72.2.92	USED ON	40466-3	
REV	ECN NO.	DATE	PHILADELPHIA, PA 19135 DRWN/DATE		
FILE:	PARTS\1183-20L		PHILADELPHIA, PA 19135 DRWN/DATE		
			INSINGER		
			PHILADELPHIA, PA 19135 DRWN/DATE		
			FAX (215) 624-8966		
			11.19.92		

ITEM	PART NO.	SIZE	DESCRIPTION	QTY.	
				STD	2 X-H @ X-H
1	D2-881	A	ROD X 25 1/2 LG.	2	2
2	D3-527	A	CURTAIN - ENTER (14 5/8 LG.)	1	1
	D3-530	A	CURTAIN - ENTER (16 5/8 LG.)		
	D3-544	A	CURTAIN - ENTER (20 5/8 LG.)		
3	D3-508	A	CURTAIN - CENTER (14 3/8 LG.)	1	1
4	D3-528	A	CURTAIN - EXIT (19 LG.)	1	1
	D3-531	A	CURTAIN - EXIT (21 LG.)		
	D3-543	A	CURTAIN - EXIT (25 LG.)		
5	D3-550	A	CURTAIN - ENTER & EXIT VESTIBULE (14 3/8 LG.)	2	2
	D3-552	A	CURTAIN - ENTER & EXIT VESTIBULE (20 3/8 LG.)		
6	D2-881	A	ROD X 21 1/2 LG.	2	2
7	D2-881	A	ROD X 24 1/2 LG.	2	2
8	1440-23	A	SUPPORT-CURTAIN CLIP	2	2
9	1183-53	A	BAFFLE. PREWASH	1	1
10	D3-508	A	CURTAIN - PREWASH-WASH (14 3/8 LG.)	1	1
	D3-508	A	CURTAIN - PREWASH-WASH (14 3/8 LG.)		
	D3-540	A	CURTAIN - PREWASH-WASH (20 3/8 LG.)		
11	1460-32	B	TOP BAFFLE	1 SET	1 SET
12	1183-60	A	BAFFLE- INSIDE SPLASH	1	1

F	REV	ECN NO	DATE	TOLERANCES	FILE: PARTS\1183-21
1607				5.71.98	
1588				12.5.97	
1572				2.31.97	
984				2.14.94	
974				72.29.93	

TITLE		RODS LOCATION	SCALE	USED ON
R.H. MACHINE SHOWN L.H. MACHINE OPPOSITE			1:8	ADM 66-3
TOP BAFFLES. CURTAINS				DRWN/DATE
NEXT ASSY DWG. NO.				PC
1183-21				

MATERIAL		INSINGER	
Phidolphia, PA 19135		(215) 624-4800	
FAX (215) 624-6966		4.28.88	

ITEM	PART NO.	SIZE	DESCRIPTION	QTY.	
				STD	2 X-HH 6 X-HH
1	D2-881	A	ROD X 25 1/2 LG.	2	2
2	D3-530	A	CURTAIN - ENTER (16 5/8 LG.)	1	1
	D3-529	A	CURTAIN - ENTER (CUT TO 18 5/8 LG.)		
	D3-551	A	CURTAIN - ENTER (22 5/8 LG.)		
3	D3-508	A	CURTAIN - CENTER (14 3/8 LG.)	1	1
4	D3-528	A	CURTAIN - EXIT (19 LG.)	1	1
	D3-531	A	CURTAIN - EXIT (21 LG.)		
	D3-543	A	CURTAIN - EXIT (25 LG.)		
5	D309-EF-4	-	WELDSTUD #10-32 X 1/2 LG.	3	3
6	D312-EF-5	-	LOCKNUT #10-32	3	3
7	1440-27	B	TOP BAFFLE	1	1
8	D3-550	A	CURTAIN - EXIT & ENTER VESTIBULE (14 3/8 LG.)	2	2
	D3-552	A	CURTAIN - EXIT & ENTER VESTIBULE (20 3/8 LG.)		
9	D2-881	A	ROD X 21 1/2 LG.	2	2
10	D2-881	A	ROD X 24 1/2 LG.	1	1
11	1440-26	A	ENTRANCE BAFFLE	1	1
12	1472-16	A	BAFFLE	1	1

L.H. SHOWN

R.H. SHOWN

VEIW A-A
L.H. MACH. SHOWN

VEIW B-B
L.H. MACH. SHOWN

TOLERANCES		NEXT ASSY/DWG. NO.	
L 1782	±0.00	TITLE TOP BAFFLES, CURTAINS, RODS	REQ'D 1 1169-56
K 1770	±0.00	LOCATION	SCALE 1:8
J 1634	±0.00	MAT'L	USED ON ADM 44
H 1602	±0.01	PHILADELPHIA, PA 19135	DRWN/DATE
REV. ECN NO. DATE	UNLESS OTHERWISE SPECIFIED	INSINGER	MAK
FILE:PARTS\1169-56		Philadelphia, PA 19135	DRWN/DATE
		FAX (215) 624-4800	2-3-93

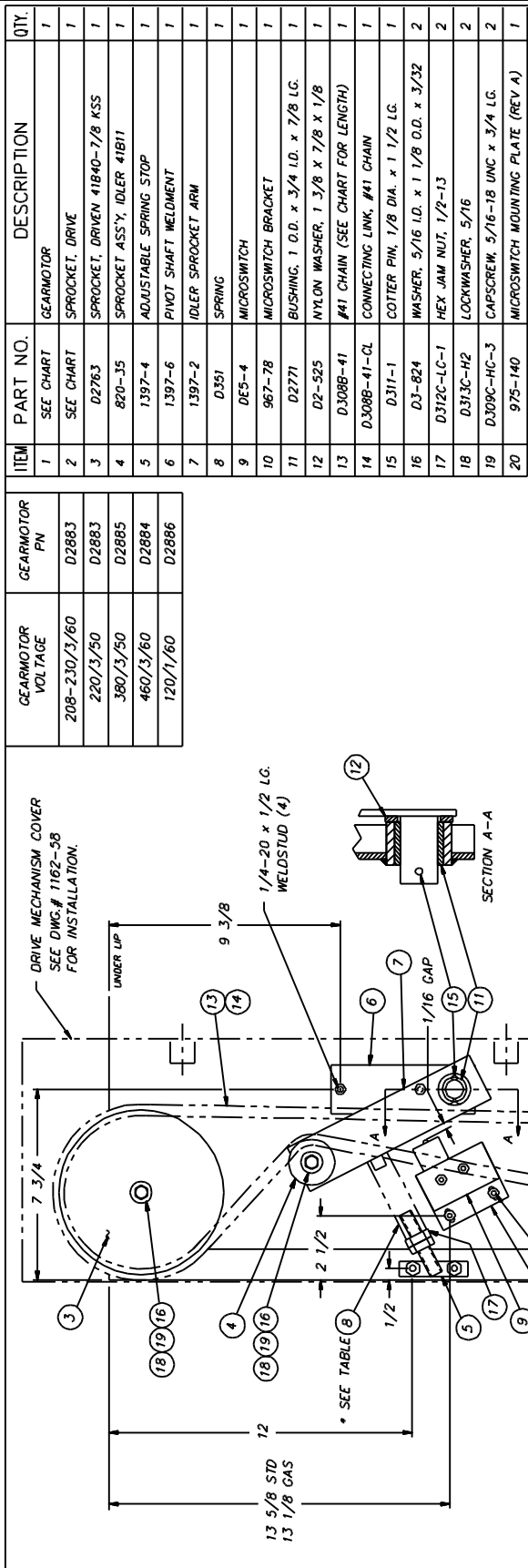

ITEM	PART NO.	DESCRIPTION	QTY.
1	SEE CHART	GEARMOTOR	1
2	SEE CHART	SPROCKET, DRIVE	1
3	D2763	SPROCKET, DRIVEN 41B40-7/8 KSS	1
4	820-35	SPROCKET ASS'Y, IDLER 41B11	1
5	1397-4	ADJUSTABLE SPRING STOP	1
6	1397-6	PIVOT SHAFT WELDMENT	1
7	1397-2	IDLER SPROCKET ARM	1
8	D351	SPRING	1
9	0E5-4	MICROSWITCH	1
10	967-78	MICROSWITCH BRACKET	1
11	D2771	BUSHING, 1 O.D. x 3/4 I.D. x 7/8 LG.	1
12	D2-525	NYLON WASHER, 1 3/8 x 7/8 x 1/8	1
13	D308B-41	#41 CHAIN (SEE CHART FOR LENGTH)	1
14	D308B-41-CL	CONNECTING LINK, #41 CHAIN	1
15	D311-1	COTTER PIN, 1/8 DIA. x 1 1/2 LG.	1
16	D3-824	WASHER, 5/16 I.D. x 1 1/8 O.D. x 3/32	2
17	D312C-LC-1	HEX JAM NUT, 1/2-13	2
18	D313C-H2	LOCKWASHER, 5/16	2
19	D309C-HC-3	CAPSCREW, 5/16-18 UNC x 3/4 LG.	2
20	975-140	MICROSWITCH MOUNTING PLATE (REV A)	1

GEARMOTOR VOL TAGE	GEARMOTOR PN
208-230/3/60	D2883
220/3/60	D2883
360/3/60	D2885
460/3/60	D2884
120/1/60	D2886

MODEL NUMBER	GEARMOTOR PN	HP	RPM	FREQ (HZ)	DRIVE SPROCKET NUMBER	SPROCKET PN	CHAIN LINKS	CHAIN OFFSET CONN	* SPRING COMPRESSION
ADMIRAL 44 & 66-4	SEE ABOVE TABLE	1/15	15	60	41B20-3/4 KSS	D2889	119	1	3 11/16
ADMIRAL 44 & 66-4			12.5	50	41B24-3/4 KSS	D2890	121	1	3 11/16
SPEEDER 64 & 86-3			15	60	41B25-3/4 KSS	D2891	123	1	3 11/16
SPEEDER 64 & 86-3			12.5	50	41B30-3/4 KSS	D2892	126	0	3 11/16
ADM 44 & 66-4 GAS			15	60	41B20-3/4 KSS	D2889	115	1	3 9/16
ADM 44 & 66-4 GAS			12.5	50	41B24-3/4 KSS	D2890	117	1	3 9/16
SUPER 106-2	62818	1/6	30	60	41B16-5/8 KSS	D2779	0	1	3 9/16
SUPER 106-2	62818	1/6	25	50	41B19-5/8 KSS	D2767	0	1	3 9/16

R.H. SHOWN, L.H. OPPOSITE

TOLERANCES	FRACTIONS ±1/64	DECIMALS .005	ANGLES ±.01	UNLESS OTHERWISE SPECIFIED
FILE: PARTS \1397-1 <td></td> <td></td> <td></td> <td></td>				
REV	ECN NO	DATE		
H	1752	4.11.00		
TITLE				DRIVE MECHANISM ASSEMBLY
NEXT ASSY DWG. NO.				1397-1
SCALE				1:4
USED ON				SEE ABOVE
MATERIAL				NOTED
INSINGER				Philadelphia, PA 19135 (215) 624-4800 FAX (215) 624-6966
				1.71.93

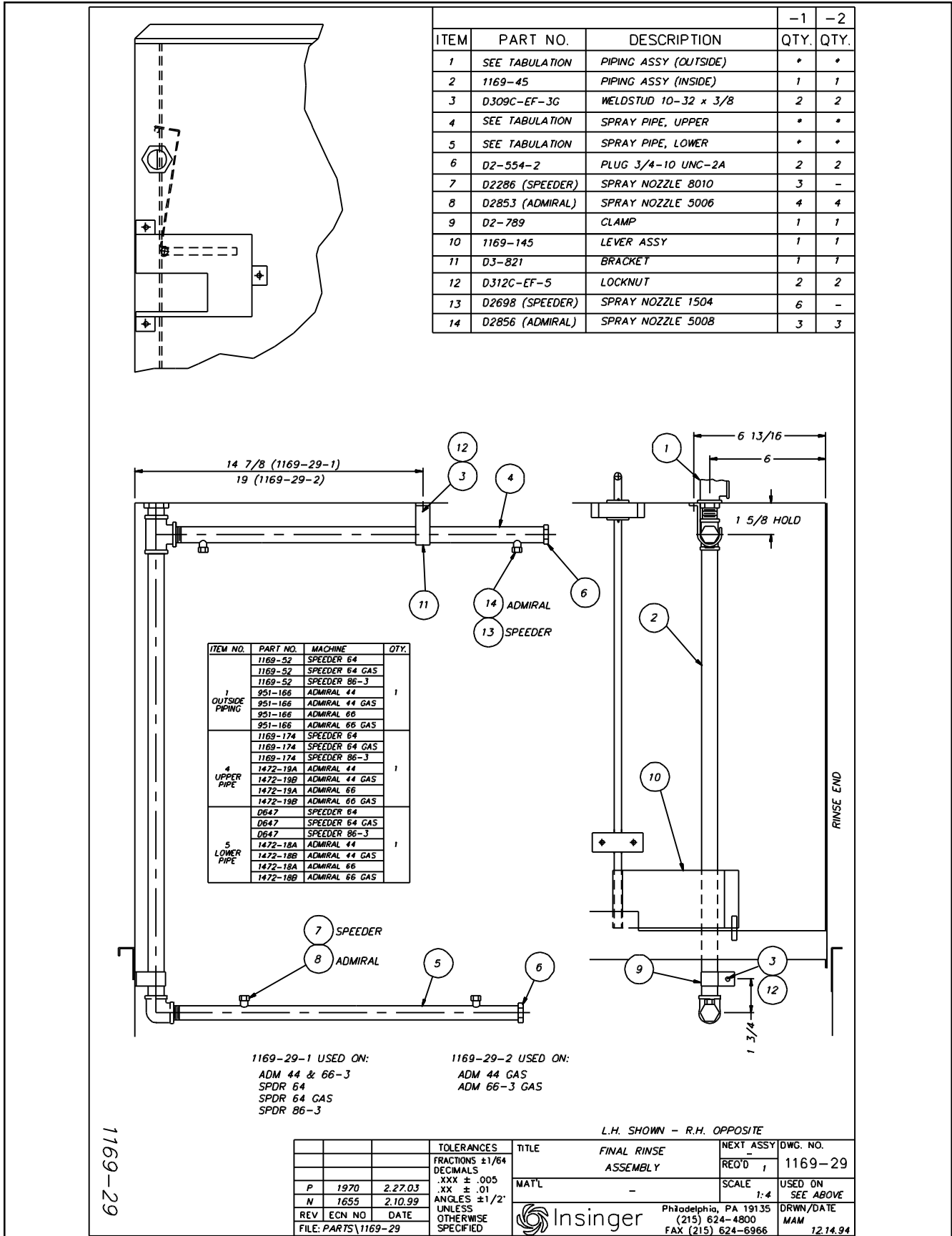

ITEM	PART NO.	SIZE	DESCRIPTION	QTY.
1	1169-146	B	LEVER WELDMENT	1
2	1169-150	A	MICRO-SWITCH BRACKET	1
3	D312C-GC-2	-	HEX NUT 1/4-20	6
4	1169-152	A	COVER	1
5	D313C-1J	-	WASHER 3/8	1
6	D310-10	-	COTTER PIN 1/8 X 1 LG.	2
7	816-58	A	SPRING	1
8	D2215A	-	MICRO-SWITCH BZE6-2RN	1
9	791-99	A	PIN, SPRING	1
10	-	-	-	-
11	-	-	-	-
12	D309C-FE-4G	-	#10-32 x 1/2 WELDSTUD	5
13	D313C-1E	-	WASHER #10	2
14	D312C-EF-5	-	LOCKNUT #10-32	2
15	D309C-CG-10A	-	HEX HD SCR 1/4-20 X 1 1/4 LG. ALL THD	2
16	D313C-2G	-	-	4
17	D309C-GC-9G	-	1/4-20 X 1 1/8 LG. WELDSTUD	2
18	D313C-1G	-	LOCKWASHER #10	3
19	D312C-EF-2	-	HEX NUT #10-32	3
20	D313C-1G	-	WASHER 1/4	2

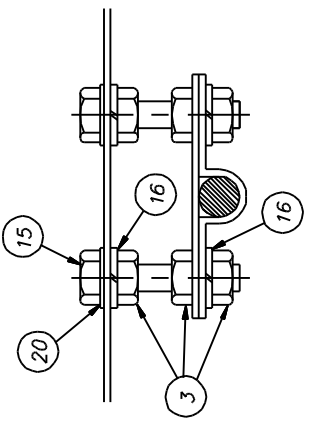
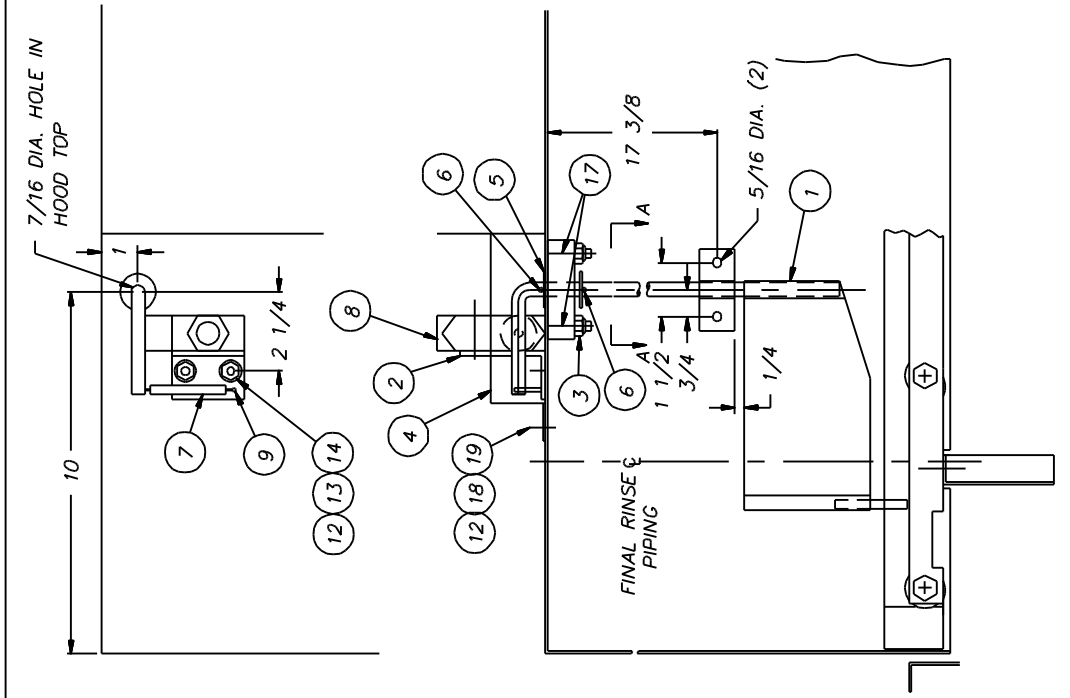

SECTION A-A

TOLERANCES		TITLE		NEXT ASSY DWG. NO.	
D	1591	1.28.98	FRACNS ±1/64	LEVER ASSEMBLY	RECD 1 1169-145
C	1557	10.6.87	DECIMALS	FINAL RINSE	SCALE 1=J USED ON ADM 44
B	809	1.25.93	XXX ± .005	NOTED	PC
A	302	8.7.89	.XX ± .01		
UNLESS OTHERWISE SPECIFIED		ANGLES ±1/2°		Philadelphia, PA 19135 DRWN/DATE	
REV	ECN NO	DATE	FILE: PARTS\1169-145	PC	

R. H. SHOWN L. H. OPPOSITE

Philadelphia, PA 19135
(215) 824-4800
FAX (215) 624-6966

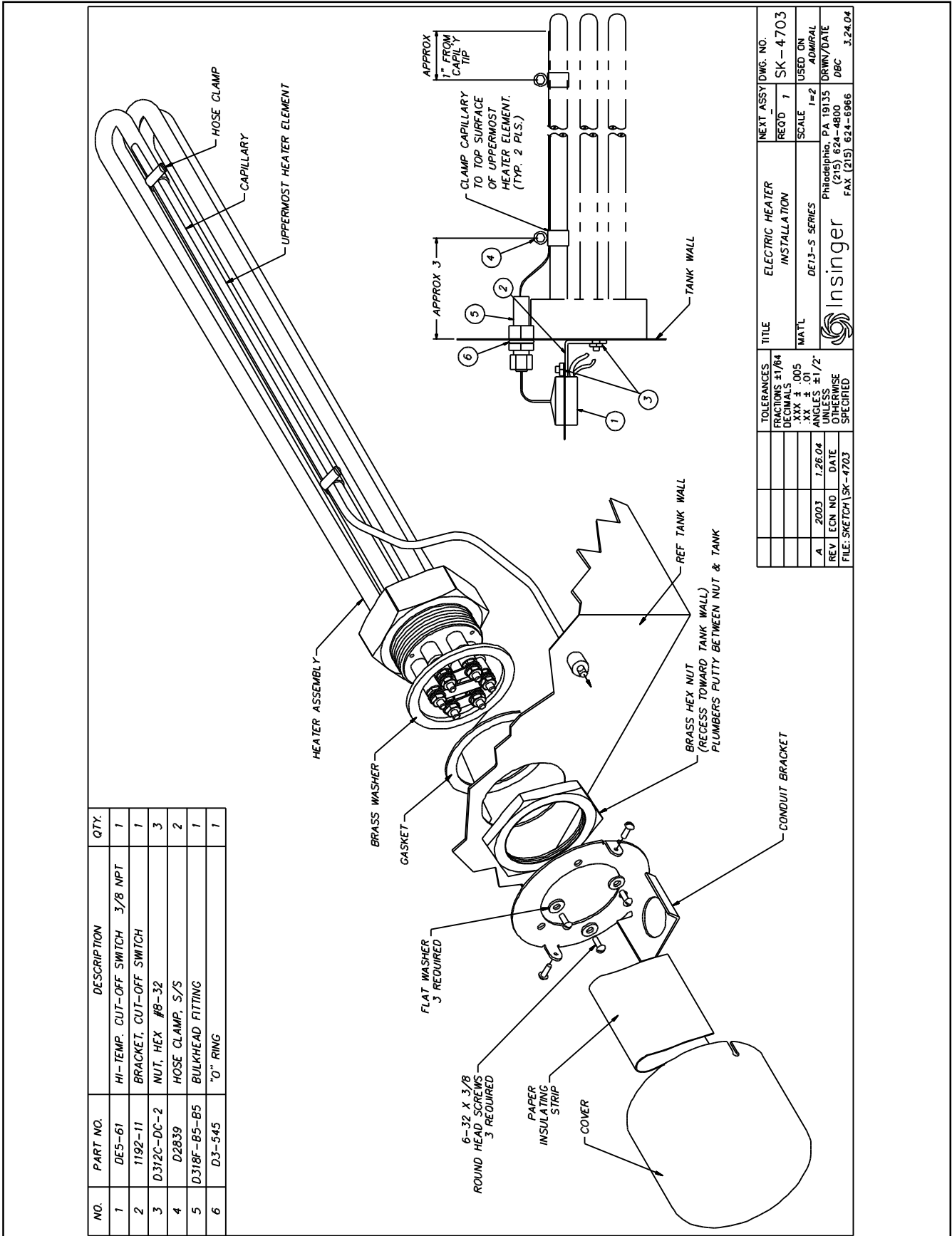

NO.	PART NO.	DESCRIPTION	QTY.
1	DE5-61	HI-TEMP. CUT-OFF SWITCH 3/8 NPT	1
2	1192-11	BRACKET, CUT-OFF SWITCH	1
3	D312C-DC-2	NUT, HEX #8-32	3
4	D2839	HOSE CLAMP, S/S	2
5	D318F-B5-B5	BULKHEAD FITTING	1
6	D3-545	"0" RING	1

TOLERANCES	FRACTIONS ±1/84	DECIMALS .XXX ±.01	ANGLES ±1/2°	UNLESS OTHERWISE SPECIFIED
REV	A	2003	1/26/04	DATE
ECN NO	FILE: SKETCH\SK-4703			
TITLE	ELECTRIC HEATER INSTALLATION	MATL	DE13-S SERIES	SCALE 1=2
REQ'D	1	USED ON	ADMIRAL	DRWN/DATE
NEXT ASSY DWG. NO.	SK-4703			DBC 3/24/04

Philadelphia, PA 19135
 (215) 624-4800
 (215) 624-6966

ITEM	PART NO.	DESCRIPTION	QTY.
1	C24-58	ELECTRIC BOOSTER	1
2	-	RELIEF VALVE 3/4" IPS	1
3	D316A-D3	90° ELBOW 1/2" C	2
4	951-49	BRACKET	1
5	D2508	3/4" STRAINER	1
6	D2340	BALL VALVE 3/4" IPS	1
7	D320F-E1	TEE 3/4" IPS	1
8	D322F-E2-B1	REDUCER 3/4" MIPS x 1/4" FIPS	1
9	D328F-B2A	PIPE PLUG 1/4" IPS	1
10	D316A-E3	90° ELBOW 3/4" C	1
11	D320F-D1-E1	TEE 1/2" FIPS x 3/4" FIPS x 3/4" FIPS	1
12	D318A-D3-D2	UNION 1/2" MIPS x 1/2" C	1
13	D207A-B4-164	COPPER TUBING 1/2" x 41" LG.	1
14	D319A-D3-D4	90° UNION ELL 1/2" MIPS x 1/2" C	1
15	D316A-D3-D4	90° FTG. ELBOW 1/2" C x 1/2" FTG.	1
16	D207A-B4-47	COPPER TUBING 1/2" CTS x 11 3/4" LG.	1
17	D207A-B4-42	COPPER TUBING 1/2" CTS x 10 1/2" LG.	1
18	D314F-E2	NIPPLE CLOSE 3/4 IPS	2
19	D207A-B6-39	COPPER TUBING 3/4" CTS x 9 3/8" LG.	1
20	D207A-B6-20	COPPER TUBING 3/4" CTS x 5" LG.	1
21	D207A-B6-47	COPPER TUBING 3/4" CTS x 11 5/8" LG.	1
22	D317A-E3-E2	ADAPTER 3/4" MIPS x 3/4" C	1
23	D316A-E1-D1	90° ELBOW 3/4" FIPS x 1/2" FIPS	1
24	D207A-B4-48	COPPER TUBING 1/2" CTS x 12" LG.	1
25	D3290-S	DRAIN COCK 1/4" IPS	1
26	D322F-D2-B1	REDUCER 1/2" MIPS x 1/4" FIPS	1
27	D318A-E3-B2	UNION 3/4" C x 3/4" MIPS	1

R.H. SHOW - L.H. OPPOSITE

TOLERANCES	NEXT ASSY DWG. NO.	RECD -	1182-47
D 1990	8.8.03	ELECTRIC BOOSTER ASSEMBLY	
C 1700	8.17.99	SCALE 1=12	
B 1506	12.4.96	USED ON SEE ABOVE	
A 510	11.26.90	F1=12	
REV. ECN NO.	DATE	UNLESS OTHERWISE SPECIFIED	
FILE: PARTS\1182-47			

Philadelphia, PA 19135 DRWN/DATE
 (215) 624-4800
 FAX (215) 624-6966 EMM 5.12.88

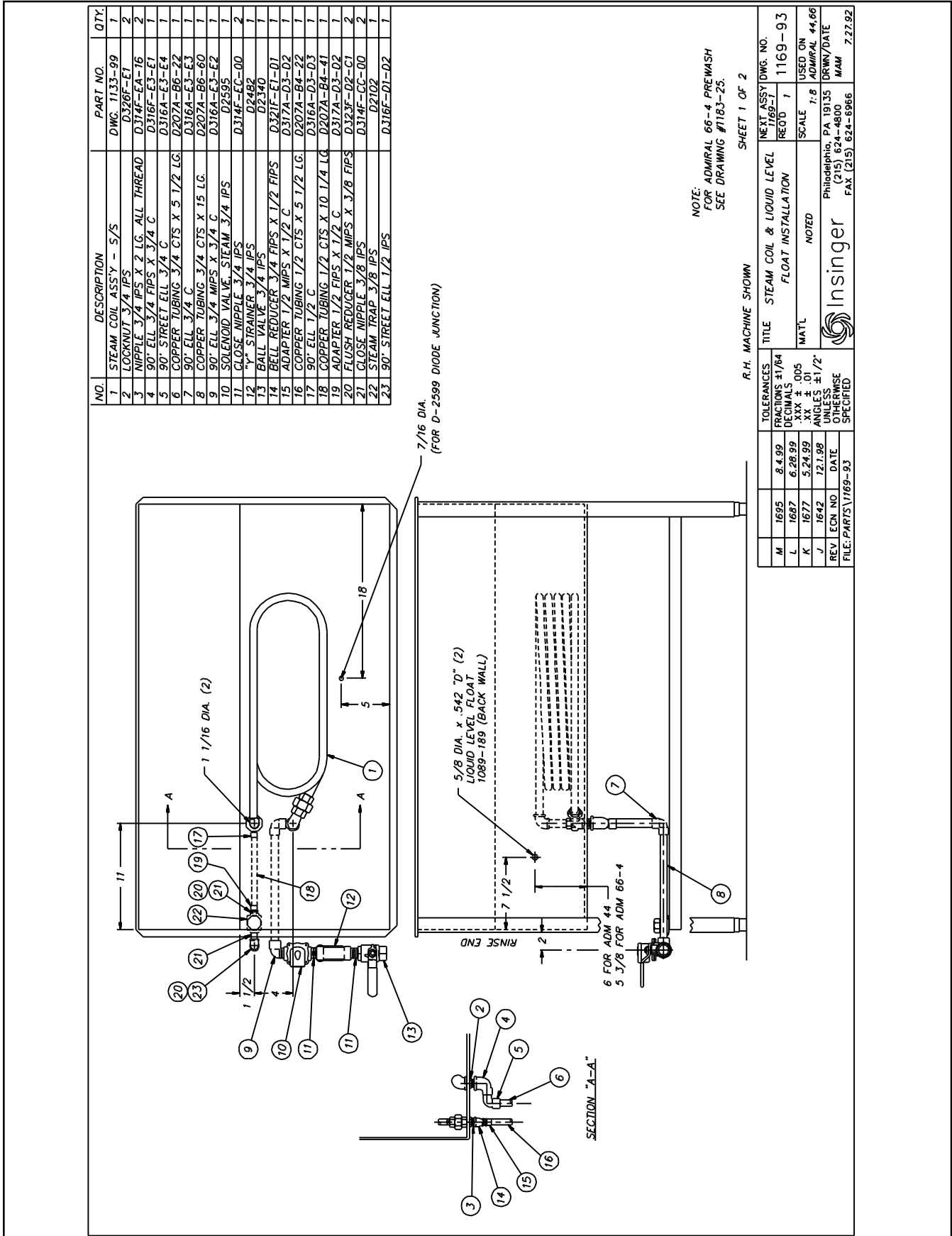

NO.	DESCRIPTION	PART NO.	QTY.
1	STEAM COIL ASSY - S/S	DWC. 1133-99	1
2	LOCKNUT 3/4 IPS	D326F-E1	2
3	NIPPLE 3/4 IPS X 2 LG. ALL THREAD	D314F-EA-16	2
4	90° ELL 3/4 FIPS X 3/4 C	D316F-E3-E1	1
5	90° STREET ELL 3/4 C	D316A-E3-E4	1
6	COPPER TUBING 3/4 CTS X 5 1/2 LG.	D207A-B6-22	1
7	90° ELL 3/4 C	D316A-E3-E3	1
8	COPPER TUBING 3/4 CTS X 15 LG.	D207A-B6-60	1
9	90° ELL 3/4 MIFS X 3/4 C	D316A-E3-E2	1
10	SOLENOID VALVE, STEAM 3/4 IPS	D2595	1
11	CLOSE NIPPLE 3/4 IPS	D314F-EC-00	2
12	"Y" STRAINER 3/4 IPS	D2482	1
13	BALL VALVE 3/4 IPS	D2340	1
14	BELL REDUCER 3/4 FIPS X 1/2 FIPS	D321F-E1-01	1
15	ADAPTER 1/2 MIFS X 1/2 C	D317A-D3-02	1
16	COPPER TUBING 1/2 CTS X 5 1/2 LG.	D207A-B4-32	1
17	90° ELL 1/2 C	D316A-D3-03	1
18	COPPER TUBING 1/2 CTS X 10 1/4 LG.	D207A-B4-41	1
19	ADAPTER 1/2 FIPS X 1/2 C	D317A-D3-02	1
20	FLUSH REDUCER 1/2 MIFS X 3/8 FIPS	D323F-D2-C1	2
21	CLOSE NIPPLE 3/8 IPS	D314F-CC-00	2
22	STEAM TRAP 3/8 IPS	D2102	1
23	90° STREET ELL 1/2 IPS	D316F-D1-02	1

TOLERANCES	FRACTIONS 31/64	DECIMALS .005	ANGLES ±1/2°	UNLESS OTHERWISE SPECIFIED
M	1695	8.4.99		
L	1687	6.28.99		
K	1677	5.24.99		
J	1642	12.1.98		
REV	ECN NO.	DATE		
FILE: PARTS\1769-93				

TITLE	STEAM COIL & LIQUID LEVEL FLOAT INSTALLATION	SCALE	USED ON ADMIRAL 44, 66
MATL	NOTED	7:8	
RECD	1		
DRWN/DATE			
MAM			

NEXT ASSY DWG. NO.	1169-93
PHILADELPHIA, PA 19135	
(215) 624-4800	
FAX (215) 624-6966	
7.27.92	

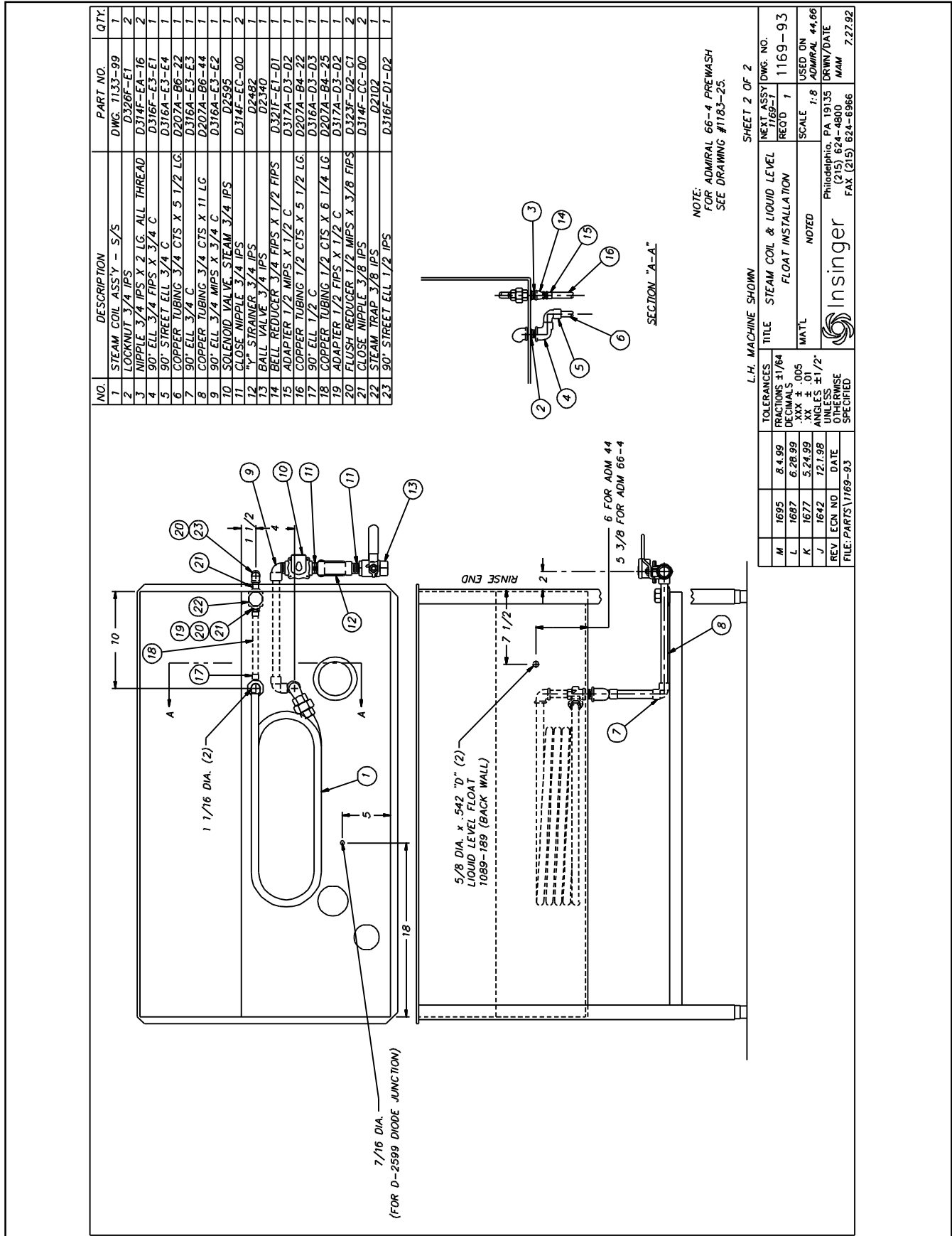

NO.	DESCRIPTION	PART NO.	QTY.
1	STEAM COIL ASS'Y - S/S	DWG. 1133-99	1
2	LOCKWUT 3/4 IPS	D326F-E1	2
3	NIPPLE 3/4 IPS X 2 LG. ALL THREAD	D314F-EA-16	2
4	90° ELL 3/4 FIPS X 3/4 C	D316F-E3-E1	1
5	90° STREET ELL 3/4 C	D316A-E3-E4	1
6	COPPER TUBING 3/4 CTS X 5 1/2 LG.	D207A-B6-22	1
7	90° ELL 3/4 C	D316A-E3-E3	1
8	COPPER TUBING 3/4 CTS X 11 LG.	D207A-B6-44	1
9	90° ELL 3/4 MIFS X 3/4 C	D316A-E3-E2	1
10	SOLENOID VALVE STEAM 3/4 IPS	D2595	1
11	CLOSE NIPPLE 3/4 IPS	D314F-EC-00	2
12	Y* STRAINER 3/4 IPS	D2482	1
13	BALL VALVE 3/4 IPS	D2340	1
14	BELL REDUCER 3/4 FIPS X 1/2 FIPS	D321F-F1-01	1
15	ADAPTER 1/2 MIFS X 1/2 C	D317A-D3-02	1
16	COPPER TUBING 1/2 CTS X 5 1/2 LG.	D207A-B4-22	1
17	90° ELL 1/2 C	D316A-D3-D3	1
18	COPPER TUBING 1/2 CTS X 6 1/4 LG.	D207A-B4-25	1
19	ADAPTER 1/2 FIPS X 1/2 C	D317A-D3-02	1
20	FLUSH REDUCER 1/2 MIFS X 3/8 FIPS	D323F-D2-C1	2
21	CLOSE NIPPLE 3/8 IPS	D314F-CC-00	2
22	STEAM TRAP 3/8 IPS	D2102	1
23	90° STREET ELL 1/2 IPS	D316F-D1-D2	1

NOTE:
FOR ADMIRAL 66-4 PREWASH
SEE DRAWING #1183-25.

TOLERANCES		L.H. MACHINE SHOWN	
M	1695	8.4.99	FRACIONS ±1/64
L	1687	6.28.99	DECIMALS .005
K	1677	5.24.99	.XX ± .01
J	1642	12.1.98	ANGLES ±1/2°
REV	ECN NO	DATE	UNLESS OTHERWISE SPECIFIED
	FILE:PARTS1769-93		

TITLE		NEXT ASSY/DWS. NO.	
STEAM COIL & LIQUID LEVEL FLOAT INSTALLATION		1169-93	
MAT'L	NOTED	SCALE	1:8
USED ON	ADMIRAL 44.66	DRWN/DATE	
Insinger		Philadelphia, PA 19135	
		(215) 624-4800	
		FAX (215) 624-6966	
		MAM 7.27.92	

NO.	DESCRIPTION	PART NO.	QTY.
1	STEAM INJECTOR 3/4 IPS	D-942A	1
2	90° ELBOW 3/4 MIPS X 3/4 C	D316A-E3-E2	1
3	BALL CHECK 3/4 IPS	D2454	1
4	CLOSE NIPPLE 3/4 IPS	D314F-EC-00	3
5	SOLENOID 3/4 IPS (24V)	D2595	1
6	1/2" STRAINER 3/4 IPS	D2482	1
7	90° STREET ELL 3/4 MIPS X 3/4 MIPS	D316A-E1-E2	1
8	NIPPLE 3/4 IPS X 2 1/2 ALL THD.	D314F-EA-20	1
9	LOCKNUT 3/4 IPS	D326F-E1	2
10	ADAPTER 3/4 MIPS X 3/4 C	D317A-E3-E1	1
11	COPPER TUBE 3/4 C X 6 LG.	D207A-B6-24	1
12	90° ELBOW 3/4 C	D316A-E2-E3	1
13	COPPER TUBE 3/4 C X 15 LG.	D207A-B6-60	1
14	BALL VALVE 3/4 IPS	D2340	1

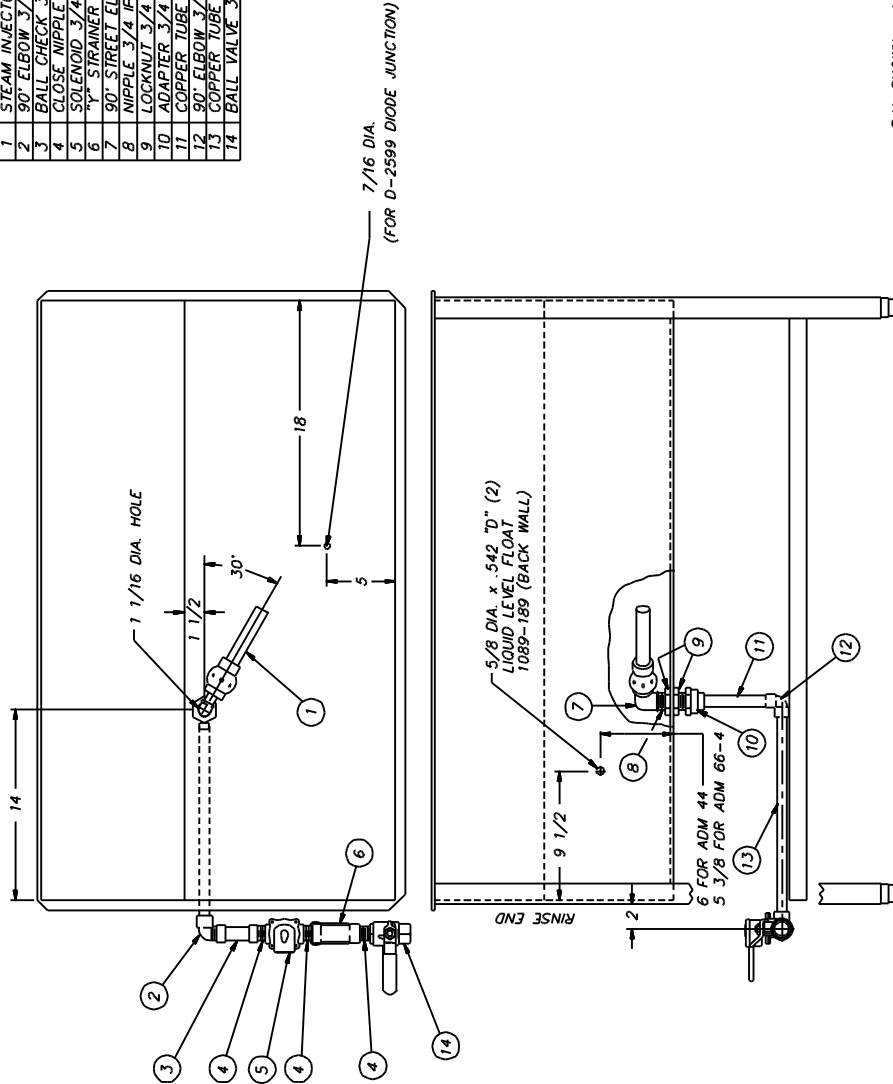

NOTE:
FOR ADMIRAL 66-4 PREWASH
SEE DRAWING #1183-25.

TOLERANCES		TITLE		NEXT ASSY DWG. NO.	
FRACTIONS	±1/64	STEAM INJECTOR & LIQUID LEVEL		REQ'D	1
DECIMALS	.005	FLOAT INSTALLATION		SCALE	1:8
XXX ±	.01	MATERIAL NOTED		USED ON	ADMIRAL #4,66
ANGLES	±1/2°	UNLESS OTHERWISE SPECIFIED		DRWN/DATE	PC
OTHERWISE		Insinger		Philadelphia, PA 19135	
FILE:PARTS\1169-94		Rev. ECN NO. DATE		Fax (215) 624-4800	
		REV. ECN NO. DATE			
H	1677	5.24.99			
G	1642	727.98			
F	1593	727.97			

R.H. SHOWN - L.H. OPPOSITE

SHEET 1 OF 2

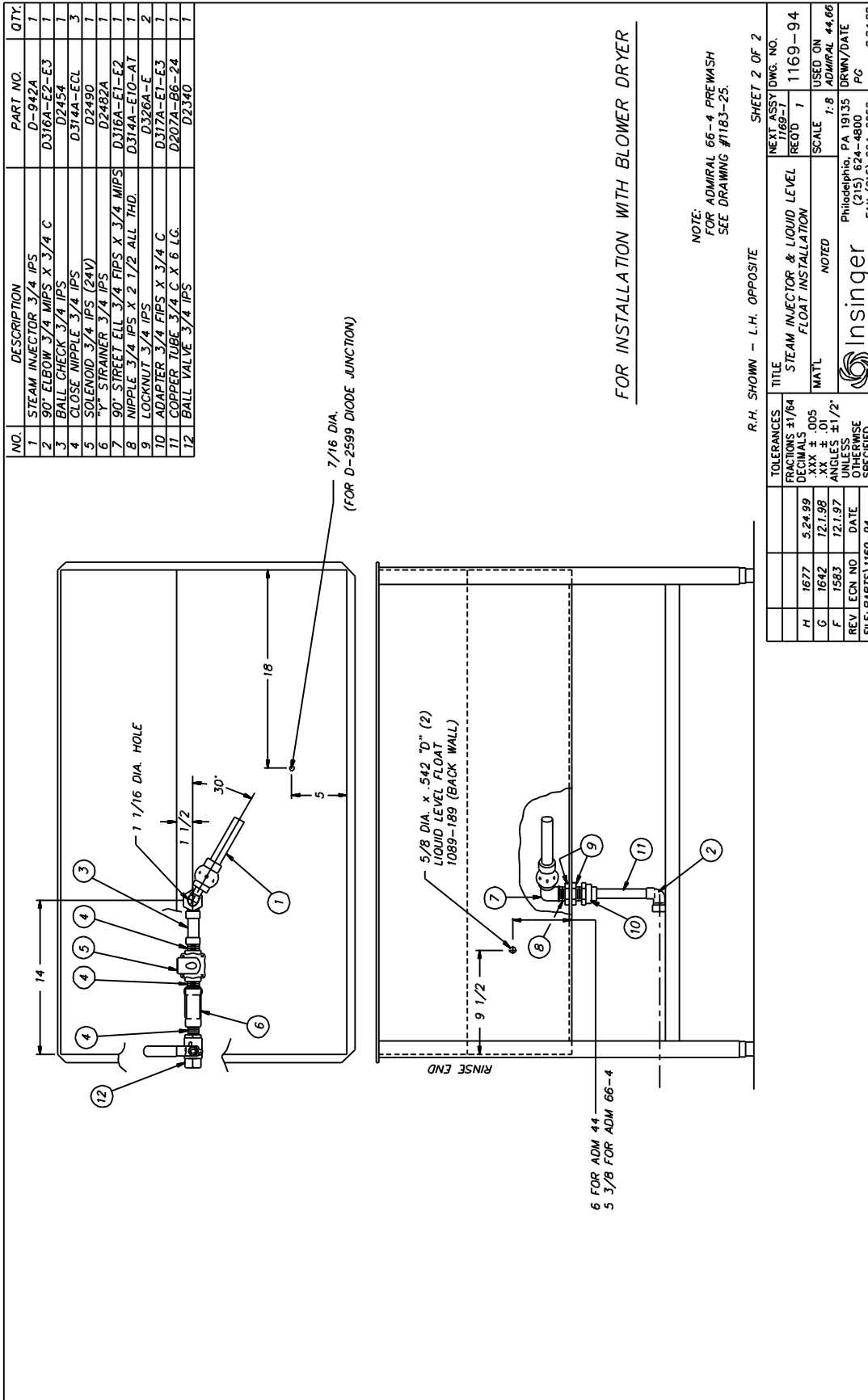

NO.	DESCRIPTION	PART NO.	QTY.
1	STEAM INJECTOR 3/4 IPS	D-942A	1
2	90° ELBOW 3/4 MIPS X 3/4 C	D316A-E2-E3	1
3	BALL CHECK 3/4 IPS	D2454	1
4	CLOSE NIPPLE 3/4 IPS	D314A-ECL	3
5	SOLENOID 3/4 IPS (24V)	D2490	1
6	1/2" STRAINER 3/4 IPS	D2482A	1
7	90° STREET ELL 3/4 FIPS X 3/4 MIPS	D316A-E1-E2	1
8	NIPPLE 3/4 IPS X 2 1/2 ALL THD.	D314A-E10-AT	1
9	LOCKNUT 3/4 IPS	D326A-F	2
10	ADAPTER 3/4 FIPS X 3/4 C	D317A-E1-E3	1
11	COPPER TUBE 3/4 C X 6 LG.	D207A-B6-24	1
12	BALL VALVE 3/4 IPS	D2340	1

TOLERANCES	TITLE	NEXT ASSY DWG. NO.
FRACTIONS ±1/64	STEAM INJECTOR & LIQUID LEVEL FLOAT INSTALLATION	1169-94
DECIMALS .xxx ± .01	MATL	SCALE 1:8
ANGLES ± 1/2° UNLESS OTHERWISE SPECIFIED	NOTED	USED ON ADMIRAL #4,66
FILE: PARTS\1169-94	Insinger	Philadelphia, PA 19135 (215) 624-4800 FAX (215) 624-6966

ITEM	PART NO.	DESCRIPTION	QTY.	ITEM	PART NO.	DESCRIPTION	QTY.	ITEM	PART NO.	DESCRIPTION	QTY.
1	D-2100	STEAM BOOSTER (1-2) (NOTE #1)	1	10	D2594	SOLENOID VALVE 1/2 IPS	1	19	D322F-E2-D1	HEX. REDUCER 3/4 MIPS X 1/2 FIPS	1
2	SK-3555	BOOSTER STAND (NOTE #3)	1	11	D2483A	"Y" STRAINER 1/2 IPS	1	20	D314F-DS-20	NIPPLE 1/2 IPS X 2 1/2 LG.	1
3	D314F-FC-00	CLOSE NIPPLE 1" IPS	1	12	D316A-E2-D3	90° ELBOW 3/4 MIPS X 1/2 C	1	21	D316F-D1-D2	90° STREET ELBOW 1/2 IPS	1
4	D316F-F2-F1	90° STREET ELL 1 MIPS X 1 FIPS	1	13	D2508A	PRESS. REG. & STRAINER 1/2 IPS	1	22	D2102A	STEAM TRAP 1/2 IPS	1
5	D316A-D3-D2	90° ELBOW 1/2 C X 1/2 MIPS	2	14	D314F-DC-00	CLOSE NIPPLE 1/2 IPS	3	23	D314F-DS-48	NIPPLE 1/2 IPS X 6 LG.	1
6	D317A-D3-F2	ADAPTER 1/2 C X 1 MIPS	1	15	D2339	BALL VALVE 1/2 IPS	2	24	D320F-E1D1D1	TEE 3/4 FIPS X 1/2 FIPS X 1/2 FIPS	1
7	D207A-K4-17	COPPER TUBING 1/2 CTS X 4 1/4 LG.	2	16	D320F-F1D1D1	TEE 1" IPS X 1/2 IPS X 1/2 IPS	1	25	D2507	PRESSURE RELIEF VALVE 3/4 IPS	1
8	D316A-D3-D3	90° ELBOW 1/2 C	1	17	D322F-D2-C1	HEX. REDUCER 1/2 MIPS X 3/8 FIPS	1	26	-	-	-
9	D207A-K4-7	COPPER TUBING 1/2 CTS X 1 3/4 LG.	1	18	D2396	THERMOSTAT (SEE NOTE #2)	1	27	D318A-D3-D2	UNION, 1/2 C X 1/2 M	1

VIEW A-A

* FOR 40° RISE ONLY

USED ON:
 *ADM 44-4
 *ADM 66-4
 *SPOR 64
 *SPOR 86-3
 *SUPER 106-2

TOLERANCES		FRACTIONS ±1/64		DECIMALS	
D	1916	2.14.02	XXX ± .01	1.17.94	AS NOTED
C	979	1.17.94	UNLESS ±1/2"	12.27.93	AS NOTED
B	964	12.27.93	UNLESS OTHERWISE SPECIFIED	70.8.93	AS NOTED
A	952	70.8.93	UNLESS OTHERWISE SPECIFIED	DATE	AS NOTED

R.H. MACHINE SHOWN - L.H. MACHINE OPPOSITE

TITLE: STEAM BOOSTER ASS'Y W/ POWER UNLOADER

SCALE: 1"=4'

USED ON: AS NOTED

REV: ECN NO. DATE

FILE: PARTS\1394-2

Philadelph, PA 19135
 (215) 624-4800
 FAX (215) 624-6966

Insinger

824-4800
 624-6966

1394-2
 1
 1
 1=4
 AS NOTED
 DRWN/DATE
 PG 7.9.93

NOTES:
 1. (ITEM #1) ADD SUFFIX "NM" FOR NON-MAGNETIC MACHINES.
 2. (ITEM #18) USE PART NO. D-2396 AS STANDARD AND PART NO. D-2301 WHEN LOW TEMP. CUT-OFF IS SPECIFIED.
 3. (ITEM # 2) USE PART NO. 975-129 FOR SHIPBOARD USE.

ITEM	PART NO.	DESCRIPTION	QTY.
1	1182-51A	NIPPLE	1
2	1460-22	DISCHARGE TUBE WELDMNT	1
3	1182-18	GASKET	1
4	D309C-CG-5G	WELDS TUD 1/4-20 x 5/8 LG.	8
5	D312C-CC-5	LOCKNUT 1/4-20 S/S	8
6	959-95	ADAPTER WELDMNT (LOWER)	1
7	D-91	LOCK PIN	2
8	1182-67	UPPER SPRAY PIPE	1
9	D2273	SPRAY NOZZLE (80-100)	3
10	D2-554-3	PLUG 7/8-9 UNC-2A	1
12	D2748	HOSE CLAMP, S/S	2
13	D2850	Braid Reinforced PVC Hose NYLONRADE 1 1/2 ID / 1.929 OD 24" LG.	1
14	1460-24	ADAPTER WELDMNT (UPPER)	1
15	1182-68	LOWER SPRAY PIPE	1
16	D2712	SPRAY NOZZLE (8070)	3
17	D-580	O" RING	1
18	D2-570	O" RING	1
19	1182-70	GASKET	1
20	1183-60	BAFFLE	1
21	1455-21	LOWER SPRAY PIPE (R86-3)	1

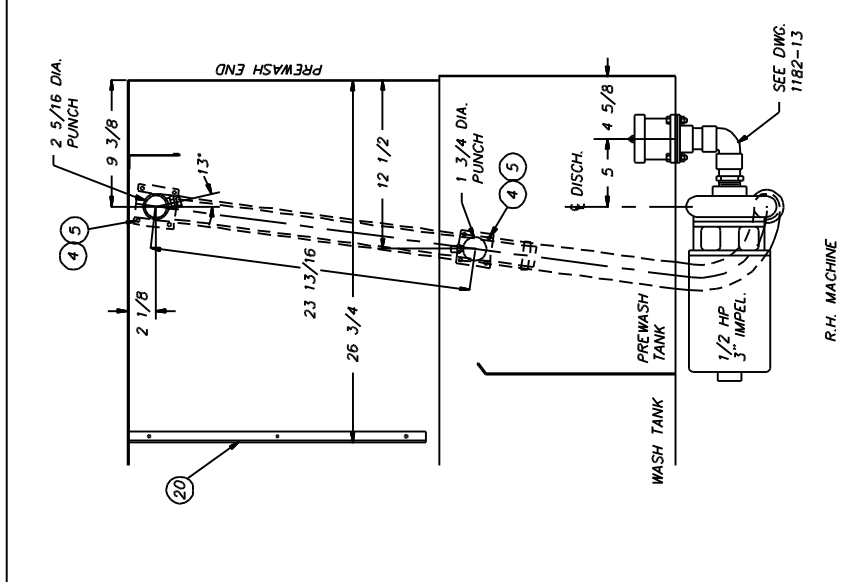
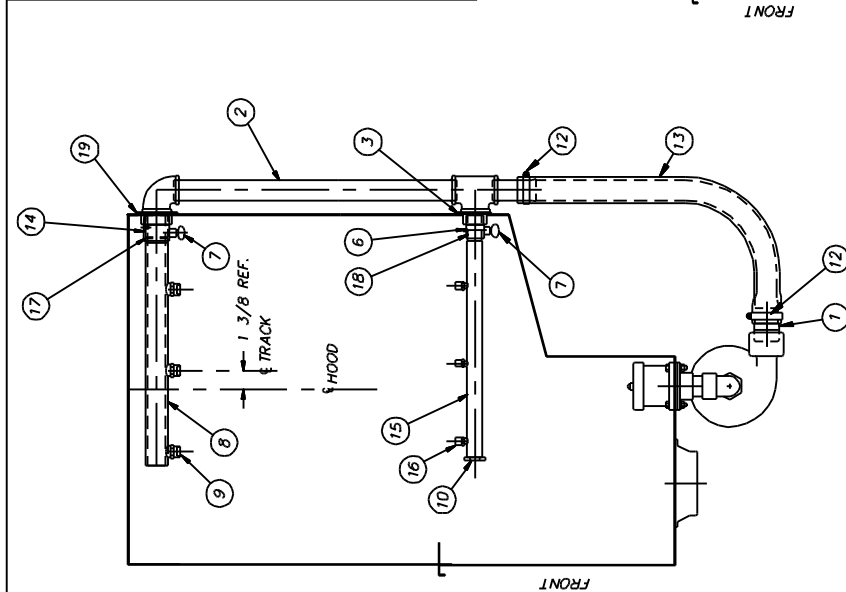

TOLERANCES	TITLE	DISCHARGE LINE ASSEMBLY	NEXT ASSY DWG. NO.
FRACTIONS ±1/64	PREWASH	REQ'D 1	1460-21
DECIMALS .005	MAT'L	SCALE	USED ON
XXX ± .01	NOTED	1=8	NOTED
ANGLES ±1/2°	INSINGER	PHILADELPHIA, PA 19135	DRWN/DATE
UNLESS OTHERWISE SPECIFIED	INSINGER	(215) 624-4800	PC
		FAX (215) 674-6966	3.16.98

ITEM	PART NO.	DESCRIPTION	QTY.
1	1182-29	SCRAP SCREEN	2
2	1183-48R	SPACER, SCRAP SCREEN	1
3	D309C-GP-3G	WELD PIN 1/4 DIA X 3/8	10

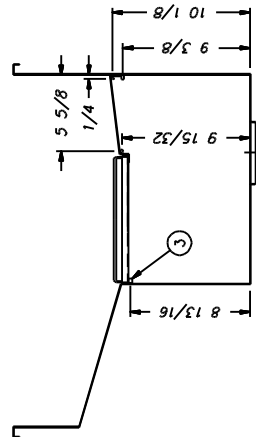
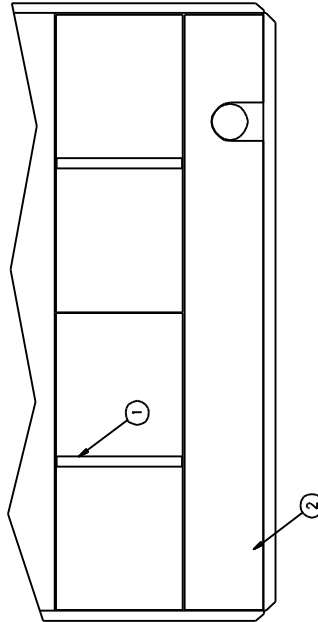
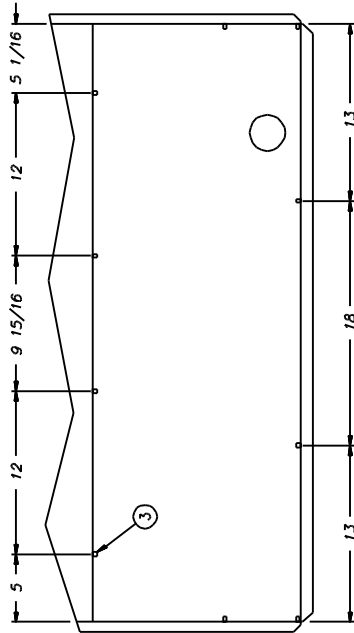

END WALLS & TANK DIVIDER

RIGHT HAND MACHINE ONLY

TOLERANCES		TITLE		NEXT ASSY DWG. NO.	
FRACTIONS ±1/8"	DECIMALS ±	SCRAP SCREEN	ARRANGEMENT	RECD	1169-12R
.xxx ± .005	.xxx ± .005	MATL	AS NOTED	SCALE	USED ON
ANGLES ±1/2°	UNLESS OTHERWISE SPECIFIED	Insinger		1-8	ADM 44
FILE: PARTS\1169-12R	DATE	Philadelphia, PA 19135		DRWN/DATE	PC
REV	EON NO	(215) 624-4800		FAX	(215) 624-6966
B	283	12.2.92		12.2.92	
C	805	2.8.93			
D	1556	6.10.97			

ITEM	PART NO.	DESCRIPTION	QTY.
1	D2-158	TANK FLANGE	1
2	1162-105L	DISCHARGE TUBE ASSY	1
3	1169-96	SUPPORT INSTALLATION	1
4	1169-53L	UPPER MANIFOLD ASSY	1
5	1169-54L	LOWER MANIFOLD ASSY	1
6	1440-32	CAPTIVE END PLUG INSTALLATION	9
7	D29.35	SPRING PLUNGER PIN	2
8	D-580	"O" RING (01-029)	2
9	D-514	GASKET	1
10			
11	D3-571	CUPSEAL/PARKER #8406-0250-4180	1
12	D373A-J1	WASHER-COPPER 318	3
13	D309C-JC-10A	HEX.HD.SCR.3/8-16 X 1 1/4	1
14	D309C-JC-11A	HEX.HD.SCR.3/8-16 X 1 3/8	3
15	D372C-JC-5	LOCKNUT 3/8-16	3
16			
17			
18	1162-109	EXTENSION-WASH MANIFOLD (90°)	2
19	D2773	SPRAY NOZZLE (80-100)	2
20			

ITEM	PART NO.	DESCRIPTION	QTY.
1	D2-158	TANK FLANGE	1
2	1162-105L	DISCHARGE TUBE ASSY	1
3	1169-96	SUPPORT INSTALLATION	1
4	1169-53L	UPPER MANIFOLD ASSY	1
5	1169-54L	LOWER MANIFOLD ASSY	1
6	1440-32	CAPTIVE END PLUG INSTALLATION	9
7	D29.35	SPRING PLUNGER PIN	2
8	D-580	"O" RING (01-029)	2
9	D-514	GASKET	1
10			
11	D3-571	CUPSEAL/PARKER #8406-0250-4180	1
12	D373A-J1	WASHER-COPPER 318	3
13	D309C-JC-10A	HEX.HD.SCR.3/8-16 X 1 1/4	1
14	D309C-JC-11A	HEX.HD.SCR.3/8-16 X 1 3/8	3
15	D372C-JC-5	LOCKNUT 3/8-16	3
16			
17			
18	1162-109	EXTENSION-WASH MANIFOLD (90°)	2
19	D2773	SPRAY NOZZLE (80-100)	2
20			

SECTION A-A

VIEW B

SECTION C-C

TOLERANCES	DISCHARGE LINE	NEXT ASSY DWG. NO.
FRACTIONS ±1/84	ASSEMBLY - LH MACHINE	1169-40L
DECIMALS	MATL	RECD 1
.XXX ± .005		SCALE 1-8
.XX ± .01		USED ON
.X ± .01		ADM 44
ANGLES ±1/2°		DRWN/DATE
UNLESS OTHERWISE SPECIFIED		PG 1,27,93

Insinger	
Philadelphia, PA 19135	
(215) 624-4800	
FAX (215) 624-6966	

NOTES:
1. END PLUG (INCLUDED IN ITEM 6)
IS D2-554-2.

ITEM	PART NO.	DESCRIPTION	QTY
1	1169-26	REAR TRACK	1
2	1169-27	TIE STRIP	1
3	D-582	BELT ROLLER	16
4	D309C-GC-14A	SCREW 1/4-20 x 1 3/4	8
5	D312C-GC-5	LOCKNUT 1/4-20	8
6	1162-50	SPACER	8

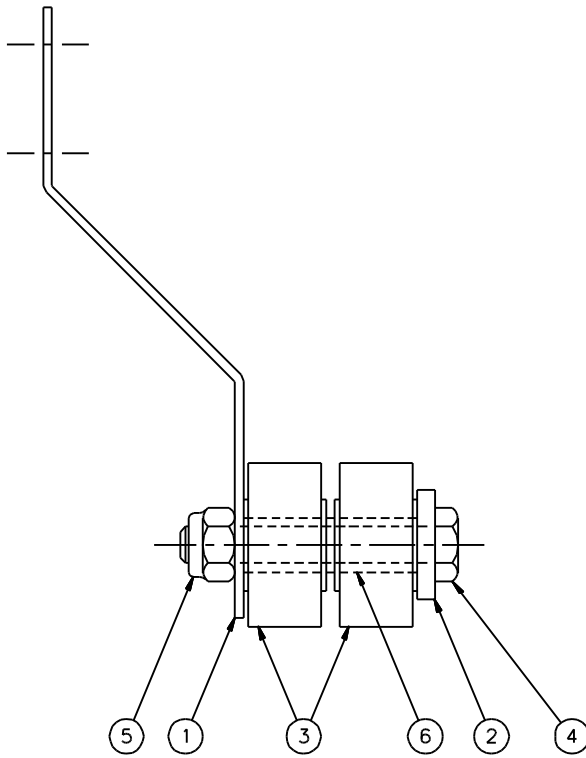

			TOLERANCES	TITLE	NEXT ASSY	DWG. NO.
			FRACTIONS ±1/64	REAR TRACK	1169-23R	1169-25
			DECIMALS	ASSEMBLY	REQ'D NOTED	
			.XXX ± .005	MAT'L	SCALE	USED ON
			.XX ± .01	NOTED	FULL	ADMIRAL 44
			ANGLES ±1/2°	 Philadelphia, PA 19135 (215) 624-4800 FAX (215) 624-6966	DRWN/DATE	
REV	ECN NO	DATE	UNLESS OTHERWISE SPECIFIED		RAF	
FILE: PARTS\1169-25						04.06.87

ITEM	PART NO.	SIZE	DESCRIPTION	QTY.
1	1431-21	B	REAR TRACK	1
2	1431-22	A	TIE STRIP	1
3	D-582	A	BELT ROLLER	24
4	D309C-GC-14A	-	SCREW 1/-20 X 1 3/4 LG.	12
5	D312C-GC-5	-	LOCKNUT 1/4-20	12
6	1162-50	A	SPACER	12

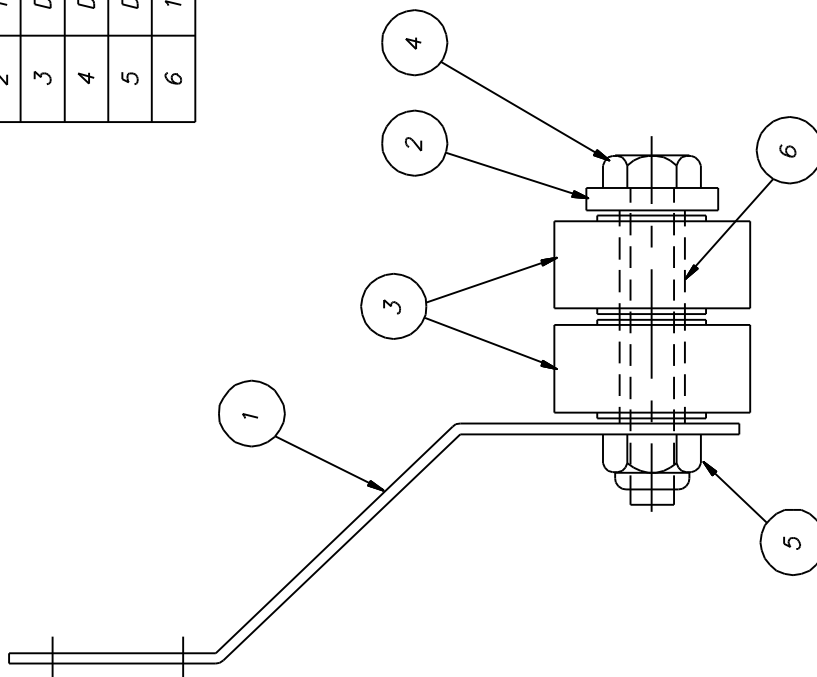

TOLERANCES	TITLE		NEXT ASSY DWG. NO.
FRACTIONS ±1/64	REAR TRACK	REQ'D 1	1183-13
DECIMALS	ASSEMBLY	SCALE 1=1	USED ON ADM 66-3
.XXX ± .005	MAT'L	NOTED	DRWN/DATE RAF
.XX ± .01	Philadelphia, PA 19135		3.10.88
ANGLES ±1/2°	(215) 624-4800		
UNLESS OTHERWISE SPECIFIED	FAX (215) 624-6966		
REV	ECN NO	DATE	
FILE: PARTS\1183-13			



Insinger Machine Company
6245 State Road
Philadelphia, PA 19135-2996
800-344-4802
Fax: 215-624-6966
www.insingermachine.com