



DISPOSERS

Technical Manual

Series I | Series N | Series S | Series G



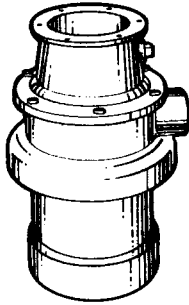

"I" Series

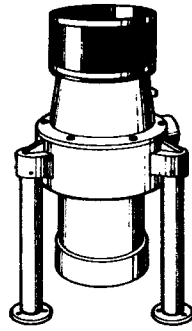

"N" Series

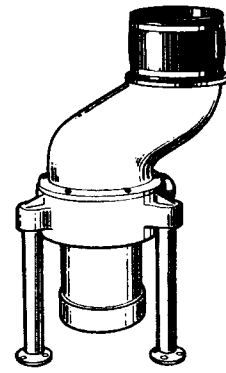

"O" Offset

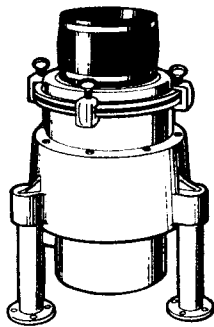

"S" Series

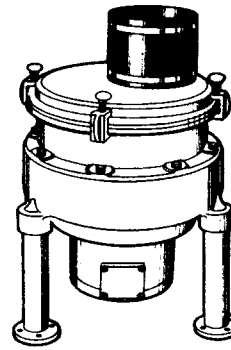

"G" Series

Ordering Instructions.....	2	Maintenance	12
Safety	3	Parts Replacement	14
General Installation	4	Parts Replacement	15
"I" Series Installation & Connection	5	"I" Replacement Parts.....	16
"N" Series Installation & Connection.....	6	"N" Replacement Parts	18
"S" Series Installation & Connection.....	7	"S" Replacement Parts	20
"G" Series Installation & Connection.....	8	"G" Replacement Parts	22
Typical Installation/Start-up & Run.....	9	"RAC1" Replacement Parts	24
Operation/Troubleshooting.....	10	"RAC2" Replacement Parts	25
Troubleshooting.....	11	Warranty.....	26

Insinger Machine Company
 6245 State Road
 Philadelphia, PA 19135
 800-344-4802
 215-624-6966 fax

ORDERING INSTRUCTIONS

Contact the Factory-authorized Parts Distributor for all parts orders or contact us directly for the name and phone number of the parts distributor nearest you:

Call : 800-344-4802

FAX : 215-624-6966

WARRANTY

All products (and parts) manufactured and sold by INSINGER DISPOSERS (the "Manufacturer") are warranted to be free from defects in material and workmanship for a period of one year following the date of their initial installation or eighteen months from the date of shipment from the factory or factory warehouse, whichever expires first. Notice of a claim under this Warranty must be received by the Manufacturer at its offices before the expiration of such period in order for Warranty coverage of **PARTS AND LABOR** to apply.

If notice of a claim is timely made, the Manufacturer will repair or replace the product or part which is defective either at the user's facility or at the Manufacturer's plant, as the Manufacturer shall decide. In addition, the Manufacturer warrants that the basic body components of every Insinger Disposer will remain serviceable for a period of at least **TEN YEARS**. Should any of these basic body components require replacement during the first ten years of normal usage following installation the Manufacturer will furnish new duplicate parts to the original user at no charge. Manufacturer cannot warrant products returned to the factory not properly packaged, causing additional damage.

This Warranty shall not apply to the extent that products or parts have been used other than in conformance with operating and maintenance instructions, subjected to misuse or abuse or damage by accident, act of God, abnormal use or stress or any other matter unrelated to the Manufacturer, and beyond its reasonable control or otherwise altered or modified by third parties. In addition, this Warranty does not cover normal wear items, such as sizing rings, impact bars and rotors. **THIS WARRANTY IS EXCLUSIVE AND IS IN LIEU OF ALL OTHER WARRANTIES, EXPRESSED AND IMPLIED, INCLUDING THE IMPLIED WARRANTIES OF MERCHANTABILITY AND FITNESS FOR PURPOSE.** In no event shall the Manufacturer be liable for loss of use, revenue or profit or for indirect or consequential damages.

SAFETY



RECOGNIZE SAFETY INFORMATION. When you see this symbol on your machine or in this manual, be alert to the potential for personal injury.

UNDERSTAND SIGNAL WORDS. DANGER, WARNING and CAUTION appear with the safety-alert symbol in this manual and on safety labels on the machine to identify the level of hazard seriousness.

DANGER indicates a hazard that WILL result in severe personal injury or death.

WARNING indicates a hazard or unsafe practice which COULD result in severe personal injury or death.

CAUTION indicates a hazard or unsafe practice which COULD result in minor personal injury or equipment damage.

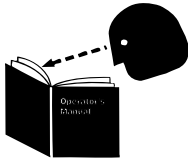

READ ALL INSTRUCTIONS

Read this owner's manual before using the machine. Failure to follow the instructions provided could result in personal injury or equipment damage.

KEEP OUT OF REACH OF CHILDREN

This disposer is intended for commercial use only.



DO NOT PUT HANDS OR ANY IMPLEMENT IN THE DISPOSER WHILE IN OPERATION.

NEVER FEED WASTE BY HAND PAST VINYL SILVER TRAP SCRAPPING RING.

DO NOT OPERATE IF DAMAGED.

Do not install or operate this disposer if the disposer has been dropped or damaged in any manner. Contact the nearest factory-authorized service center for examination, repair or adjustment. (Refer to the service center list included in the Owner's Information Packet.)

DO NOT LEAVE DISPOSER UNATTENDED.

SET THE POWER SWITCH TO OFF BEFORE CLEARING JAMS OR REMOVING OBJECTS FROM DISPOSER.

When the disposer is wired to a Manual Control or Model RAC1 Control Center, SHUT OFF the branch circuit main switch or disconnect.

When disposer is wired to a RAC2 Control Panel, TURN OFF emergency disconnect.

Use long-handled tongs or pliers to remove objects.

TO REDUCE THE RISK OF INJURY BY MATERIALS THAT MAY BE EXPELLED BY DISPOSER, DO NOT PUT THE FOLLOWING INTO DISPOSER: drain cleaner; glass, china or plastic; large, whole bones; metal (bottle cas, tin cans, aluminum foil, etc.); whole cornhusks.

ALWAYS KEEP VINYL SILVER TRAP SCRAPPING RING OR SINK STOPPER IN PLACE ON SERIES "H-RSA", EVEN WHEN NOT IN USE.

This reduces the risk of objects falling into the disposer.



WHEN CLEANING KITCHEN AND DISPOSER AREA, ONLY DAMP WIPE OUTSIDE OF DISPOSER AND CONTROLS. DO NOT AT ANY TIME HOSE DOWN THE EXTERIOR SURFACES OF THE DISPOSER AND CONTROLS.

SAVE THESE INSTRUCTIONS.

Keep this booklet in a convenient location for future reference.



GENERAL INSTALLATION

FABRICATING

1. Consult installation and connection data and installation diagrams on following pages for regular cone or regular sink attachment dishtable cutout sizes.
2. For cone attachment, position cone so water swirl inlet fitting is nearest to operator.
3. Weld the total circumference of cone or sink attachment to prevent leakage.
4. Smooth grind and polish to match and blend weld seams.

NOTE: DO NOT PLACE CONTROL MOUNTING BRACKETS IN DIRECT WATER SPLASH AREAS.

PLUMBING

1. Consult installation and connection data and installation diagrams on following pages for mounting, hookups and pipe sizes.
2. "I" Series is mounted by suspending from dishtable.
3. "N", "G" and "S" Series use a floor leg support system with a neoprene connecting sleeve and two (2) stainless steel clamps. Supplied sleeve (8" length) should be cut to required length for connection of disposer to dishtable.
4. Slide in, or position, disposer to connect to waste line, avoiding as many bends, elbows and tees as possible.
5. Flexible drain connection should be installed as follows:
 - A. Slip coupling over disposer outlet, then onto drain pipe.
 - B. Using a 5/16" nut driver, tighten to a torque of 60 in-lbs.
6. Perform power-rotor reaming of waste line whether connection is made to a new or old waste line. New lines often contain foreign items left in the lines accidentally during construction.
7. Blow new water feed lines out before connections are made. Dirt, solder, or other foreign matter can lodge itself in the flow controls, solenoid valve and vacuum breaker, causing malfunction.
8. Install solenoid valve. Check that inlet and outlet ports are in proper direction.
9. Check that disposer and dishtable opening are in line, level and true. This is visible when neoprene sleeve is not kinked or partially collapsed. If level and in line adjustment is required, turn feet on bottom of legs.
10. Secure disposer to floor using the holes provided in the feet.

ELECTRICAL

NOTE: FOLLOW GUIDELINES SET FORTH BY NEC STANDARD AND LOCAL CODES.

1. Consult installation and connection data and diagrams on following pages for control placement and motor wiring.

NOTE: DO NOT PLACE CONTROL IN DIRECT WATER SPLASH AREAS.

2. Follow supplied wiring schematics for all controls, solenoid valves and pre-wired custom control centers.
3. Size and fuse disposer branch circuit or use circuit breakers as required by motor nameplate rating.
4. Check that motor voltage wiring matches incoming voltage.

NOTE: ALL CONDUIT AND FITTINGS SHALL BE OF THE NEMA 4 WATERTIGHT TYPE.

5. All "I" and "N" disposers have thermal protection of the manual reset type, in motor. Check that reset button is not jammed.
6. All "S" and "G" disposers must have thermal protection (heaters) in control. Check that heaters are sized properly to prevent either motor burnout or nuisance tripping.
7. Check that all connections are tight, secure and well-grounded.

NOTE: Disposers are designed to operate in both a clockwise and counter-clockwise direction. Direction of rotation does not have to be considered when wiring motor.

GROUNDING

Connect disposer to a grounded metal permanent wiring system or run a disposer grounding conductor with the circuit conductors and connect it to the disposer grounding terminal or lead on the disposer.

"I" SERIES - Installation and Connection

NOTE: PLUMBING AND ELECTRICAL CONNECTIONS SHALL BE MADE IN COMPLIANCE WITH APPLICABLE LOCAL CONSTRUCTION CODES.

PLUMBING

Inlet: Cold water supply to disposer shall be 1/2" service line with a minimum of 20 lbs. flow pressure, piped as close to disposer as possible. All disposer and control connections shall be 1/2" pipe size.

Sewer Outlet: 1 1/2" waste line should have trap with conveniently located clean out. *Do not connect through a grease trap.* Avoid bends, elbows, tees, etc., to reduce the possibility of plumbing stoppage. A globe valve, used for metering flow, must be installed between solenoid valve and cone or sink. Water swirl inlet valves should be located nearest operator.

See Typical Installation Diagram.

ELECTRICAL

Follow guidelines set forth by NEC standards. Disposer branch circuit shall be sized and fused (circuit breakers) as required by motor. The disposer must be connected to a grounded, metal, permanent wiring system; or a disposer-grounding conductor must be run with the circuit conductors and connected to the disposer-grounding terminal or lead on disposer. All connections, junction boxes and conduits must be watertight (NEMA 4).

TESTING See Start-up and Run Section.

INSTALLATION DIAGRAM

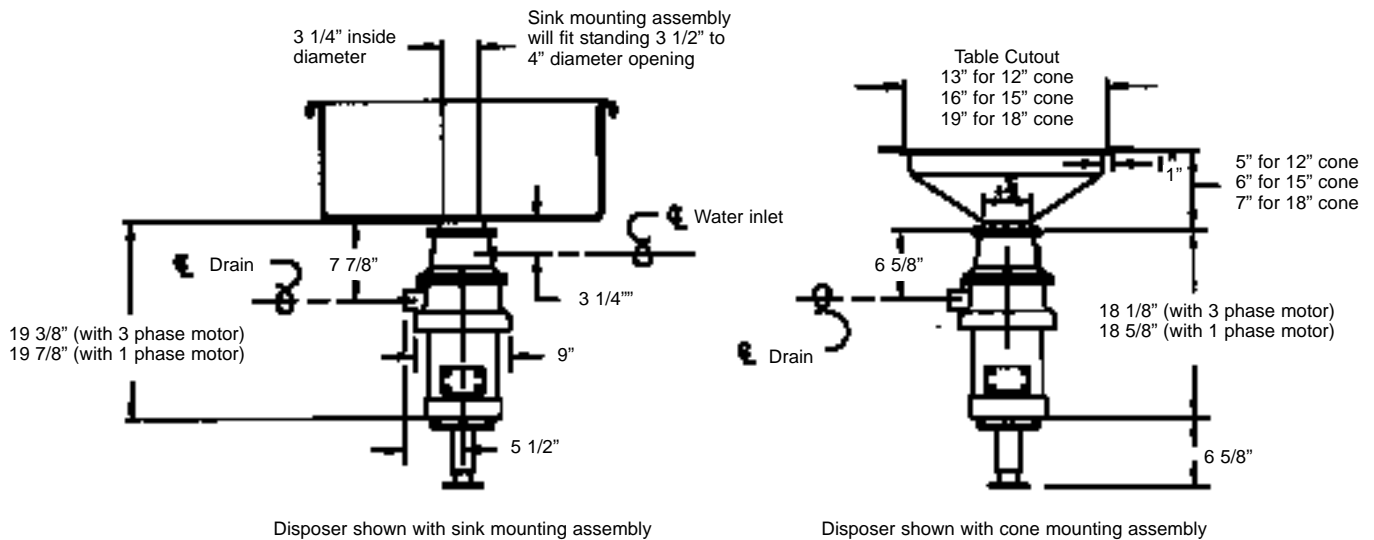

MOTOR WIRING DIAGRAM

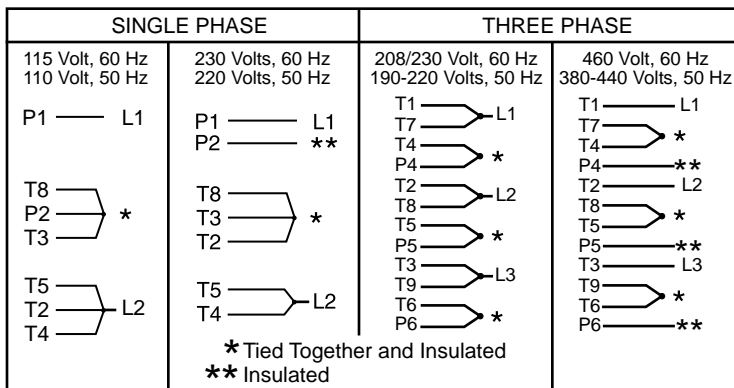

VOLTAGE-AMPERAGE TABLE

HP	SINGLE PHASE		THREE PHASE	
	Volts	Amps*	Volts	Amps*
3/4	115	5.4	208	2.8
	230	10.8	230	2.8
1 1/2	115	12.8	208	3.6
	230	6.4	230	3.6
			460	1.8

*Ratings are for 60 Hz operation.

"N" SERIES - Installation and Connection

NOTE: PLUMBING AND ELECTRICAL CONNECTIONS SHALL BE MADE IN COMPLIANCE WITH APPLICABLE LOCAL CONSTRUCTION CODES.

PLUMBING

Inlet: Cold water supply to disposer shall be 1/2" service line with a minimum of 20 lbs. flow pressure, piped as close to disposer as possible. All disposer and control connections shall be 1/2" pipe size.

Sewer Outlet: 2" waste line should have trap with conveniently located clean out. *Do not connect through a grease trap.* Avoid bends, elbows, tees, etc., to reduce the possibility of plumbing stoppage. A globe valve, used for metering flow, must be installed between solenoid valve and cone or sink. Water swirl inlet valves should be located nearest operator.

See Typical Installation Diagram.

ELECTRICAL

Follow guidelines set forth by NEC standards. Disposer branch circuit shall be sized and fused (circuit breakers) as required by motor. The disposer must be connected to a grounded, metal, permanent wiring system; or a disposer-grounding conductor must be run with the circuit conductors and connected to the disposer-grounding terminal or lead on disposer. All connections, junction boxes and conduits must be watertight (NEMA 4).

TESTING See Start-up and Run Section.

INSTALLATION DIAGRAM

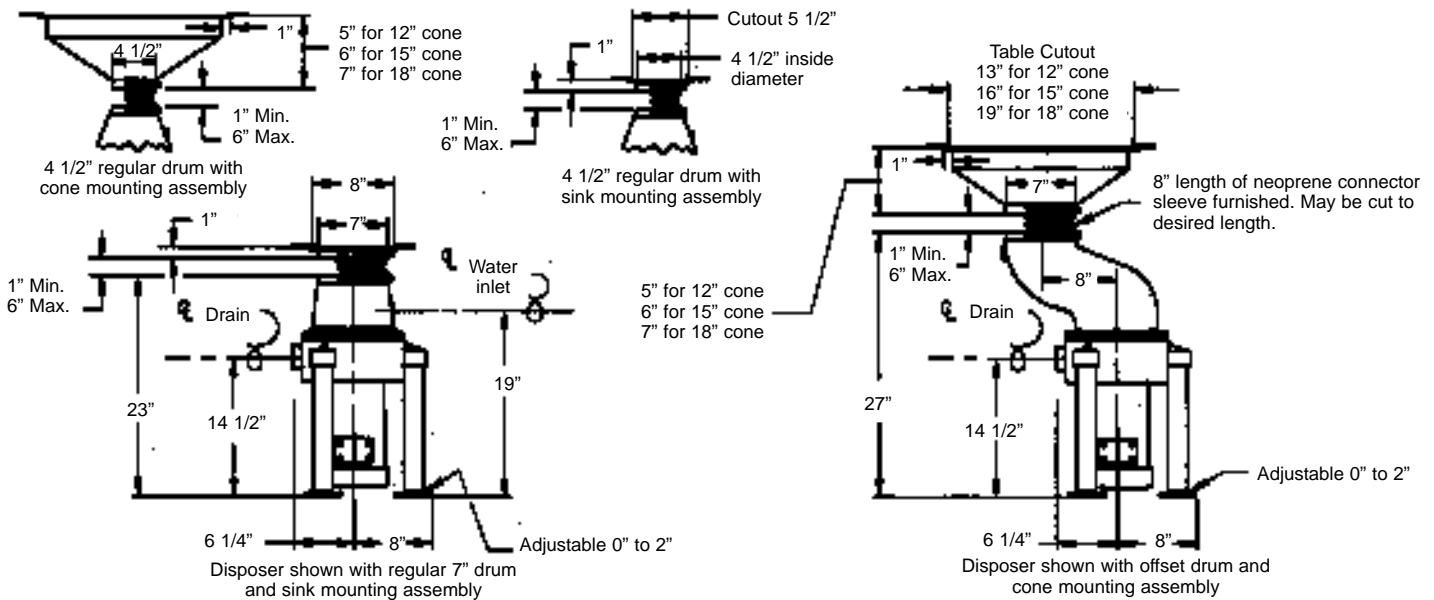

Note: All dimensions shown at 0" foot height adjustment

MOTOR WIRING DIAGRAM

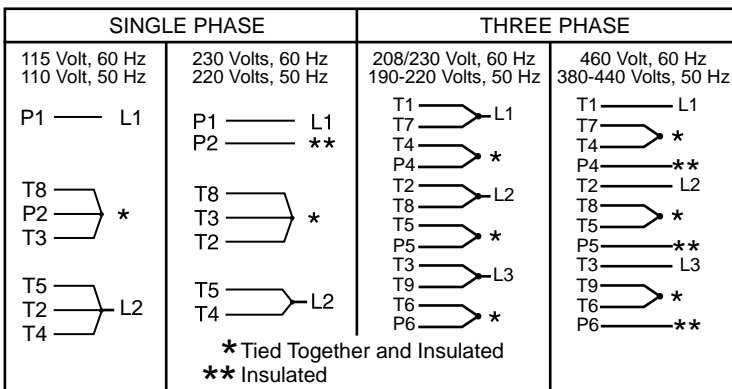

VOLTAGE-AMPERAGE TABLE

HP	SINGLE PHASE		THREE PHASE	
	Volts	Amps*	Volts	Amps*
1 1/2	115	17.2	208	4.9
	230	8.6	230	4.4
2	115	18.4	208	6.9
	230	9.2	230	6.2
3	NA		460	3.1
			208	9.7
			230	8.8
			460	4.4

*Ratings are for 60 Hz operation.

"S" SERIES - Installation and Connection

NOTE: PLUMBING AND ELECTRICAL CONNECTIONS SHALL BE MADE IN COMPLIANCE WITH APPLICABLE LOCAL CONSTRUCTION CODES.

PLUMBING

Inlet: Cold water supply to disposer shall be 1½" service line with a minimum of 20 lbs. flow pressure, piped as close to disposer as possible. All disposer and control connections shall be 1½" pipe size.

Sewer Outlet: 2" waste line should have trap with conveniently located clean out. *Do not connect through a grease trap.* Avoid bends, elbows, tees, etc., to reduce the possibility of plumbing stoppage. A globe valve, used for metering flow, must be installed between solenoid valve and cone or sink. Water swirl inlet valves should be located nearest operator.

See Typical Installation Diagram.

ELECTRICAL

Follow guidelines set forth by NEC standards. Disposer branch circuit shall be sized and fused (circuit breakers) as required by motor. The disposer must be connected to a grounded, metal, permanent wiring system; or a disposer-grounding conductor must be run with the circuit conductors and connected to the disposer-grounding terminal or lead on disposer. All connections, junction boxes and conduits must be watertight (NEMA 4).

TESTING See Start-up and Run Section.

INSTALLATION DIAGRAM

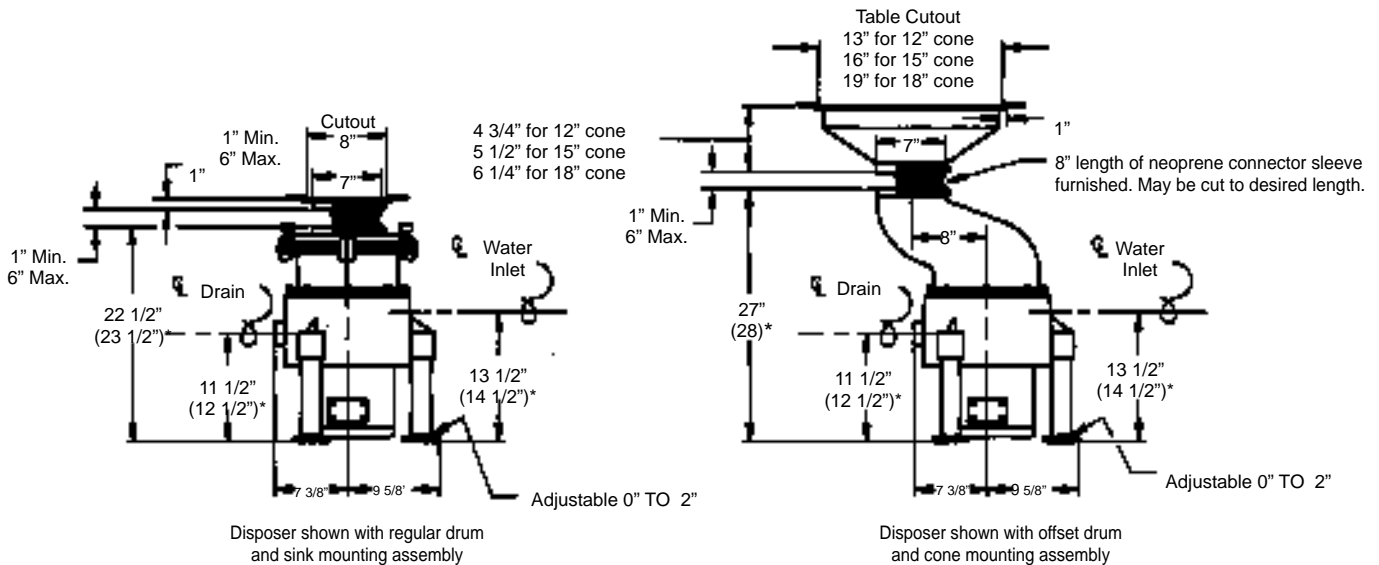

NOTE: All dimensions shown at 0" foot height adjustment.

MOTOR WIRING DIAGRAM

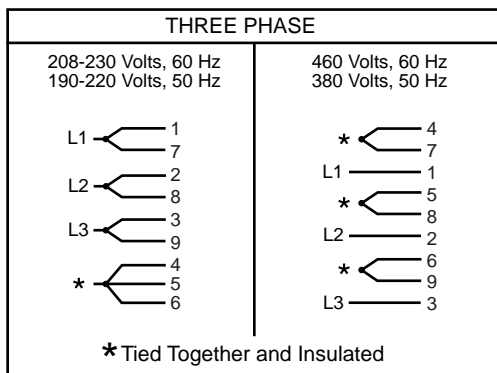

VOLTAGE-AMPERAGE TABLE

HP	THREE PHASE	
	Volts	Amps*
3	208	4.9
	230	4.4
	460	2.2
5	208	6.9
	230	6.2
	460	3.1

*Ratings are for 60 Hz operation.

"G" SERIES - Installation and Connection

NOTE: PLUMBING AND ELECTRICAL CONNECTIONS SHALL BE MADE IN COMPLIANCE WITH APPLICABLE LOCAL CONSTRUCTION CODES.

PLUMBING

Inlet: Cold water supply to disposer shall be 1/2" service line with a minimum of 20 lbs. flow pressure, piped as close to disposer as possible. All disposer and control connections shall be 1/2" pipe size.

Sewer Outlet: 3" waste line should have trap with conveniently located clean out. *Do not connect through a grease trap.* Avoid bends, elbows, tees, etc., to reduce the possibility of plumbing stoppage. A globe valve, used for metering flow, must be installed between solenoid valve and cone or sink. Water swirl inlet valves should be located nearest operator.

See Typical Installation Diagram.

ELECTRICAL

Follow guidelines set forth by NEC standards. Disposer branch circuit shall be sized and fused (circuit breakers) as required by motor. The disposer must be connected to a grounded, metal, permanent wiring system; or a disposer-grounding conductor must be run with the circuit conductors and connected to the disposer-grounding terminal or lead on disposer. All connections, junction boxes and conduits must be watertight (NEMA 4).

TESTING See Start-up and Run Section.

INSTALLATION DIAGRAM

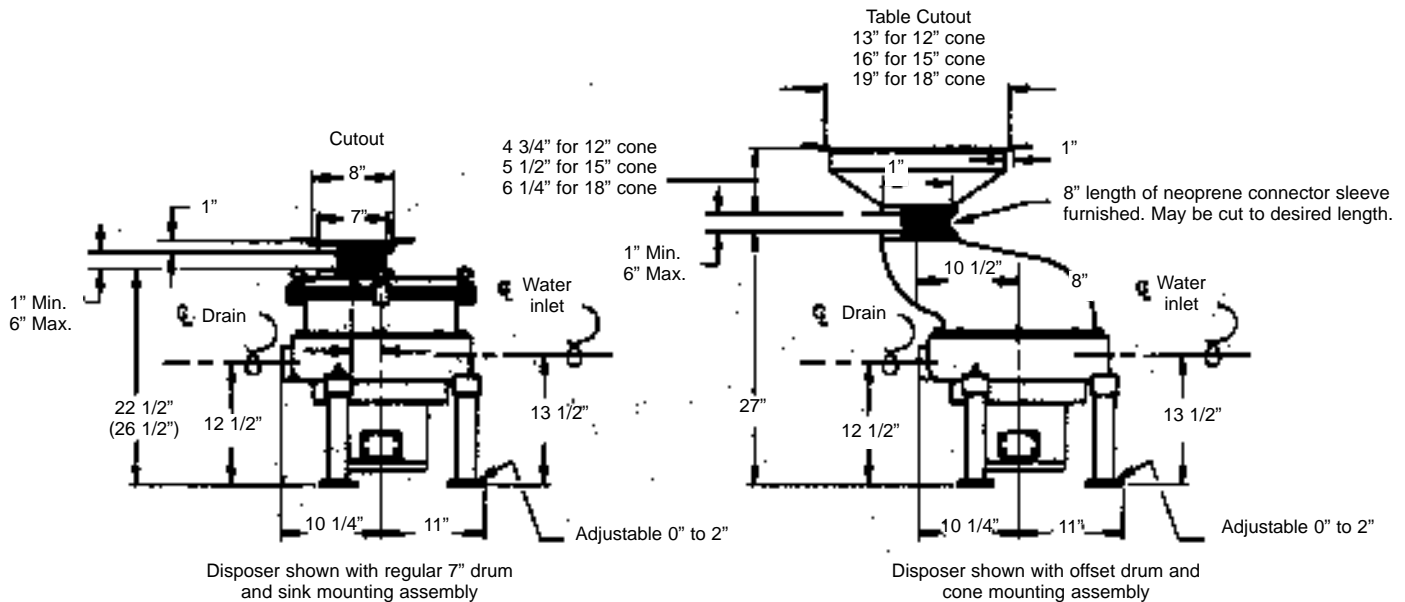

Note: All dimensions shown at 0" foot height adjustment

MOTOR WIRING DIAGRAM

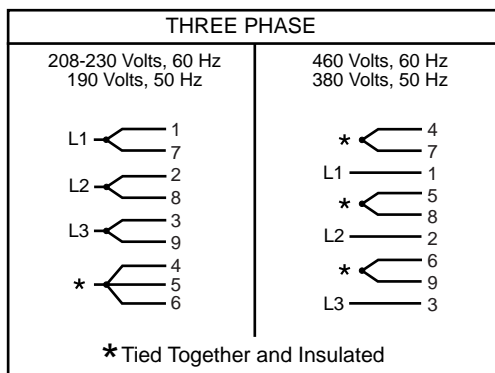

VOLTAGE-AMPERAGE TABLE

HP	THREE PHASE	
	Volts	Amps*
7 1/2	208	23.0
	230	22.0
	460	6.8
10	208	33.0
	230	30.0
	460	15.0

*Ratings are for 60 Hz operation.

TYPICAL INSTALLATION

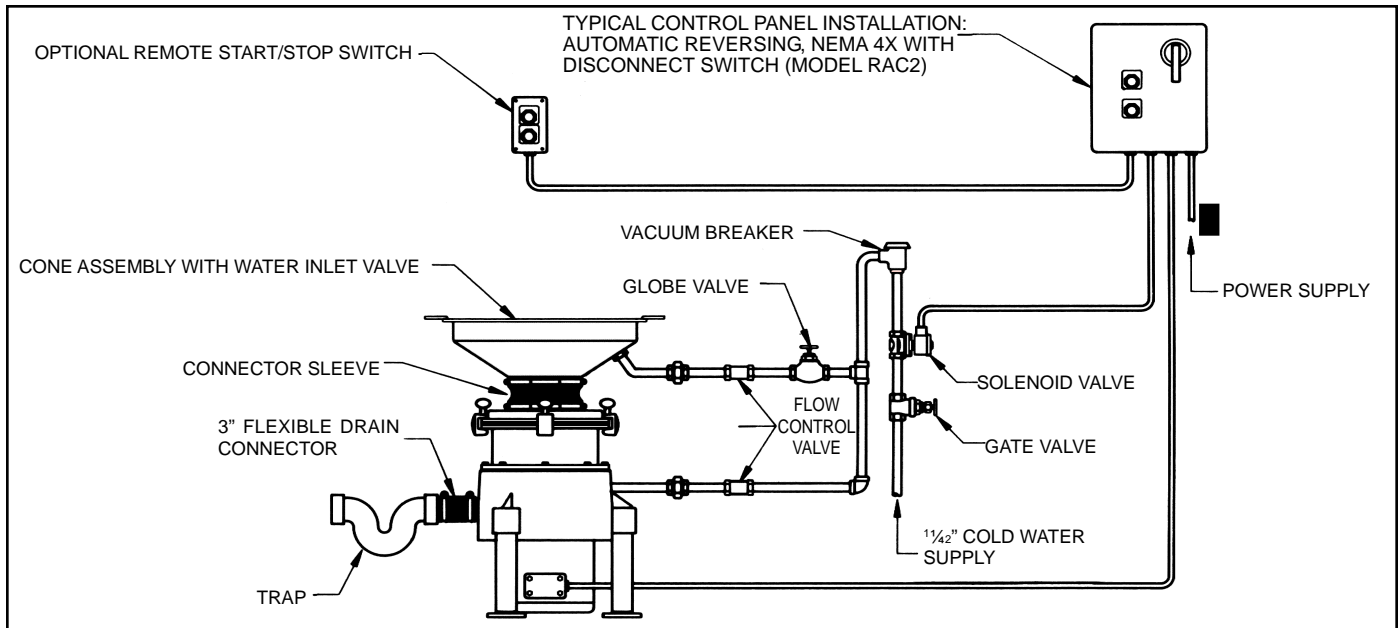

START-UP AND RUN CHECK

1. Check that vinyl silver trap scrapping ring is fully seated.
2. Check that all connections are secure.
3. Check that disposer is secured to floor.
4. Open terminal wiring box on motor; pull out and separate motor leads to permit ampere reading on each leg. Leave all connections and insulation in place.
5. Clamp ammeter over input feed lead.
6. Turn on disposer.
7. Take ampere readings on each leg and verify against factory-checked motor test results (copy attached to disposer and should be attached to Page 15 in this Owner's Manual).
8. Check for leaks, water flow, excessive noise or vibration, and regulate water flow if required.

NOTE: Before checking rotation reversal, be sure disposer is empty. Wear safety glasses or goggles. BE SURE POWER SWITCH IS OFF SHOULD ADJUSTMENTS ON DISPOSER BE NECESSARY. NEVER REACH INTO DISPOSER WHEN DISPOSER IS RUNNING.

9. If disposer is connected to a reversing control, whether automatic or manual, check reversing.
10. If disposer is connected to a manual reversing drum switch or contactor, START motor in forward position and note rotation through top opening as motor coasts to a stop. RESTART motor in reverse position. Verify that disposer restarted in opposite direction.
11. If disposer is connected to a control center with automatic reversing (Model RAC1), verify if disposer reverses.
NOTE: Motor must be stopped or 30 seconds must have elapsed before pushing START; otherwise, motor will not reverse. This is a safety cycle feature. Should START button be pressed earlier, motor will just run in same direction. Push START. When disposer runs, press STOP and note coast down direction. When motor has stopped, push START and note reversing of rotation.
12. If disposer is wired with a RAC2, rotation reversing is done the same as #11 above, except that the control panel will first switch over to a 2-minute clean-out cycle, as shown by the green light. Verify this time, keeping the solenoid valve open and motor running. When the 2 minutes have elapsed and motor has stopped, turn ON disposer and note rotation.
13. In all shutdown phases, be sure water is being shut off by the closing of the solenoid valve.
14. Reinsert all wiring, close all covers and shut all doors that were open during run check.

OPERATION

1. Check that disposer is empty and clean from previous use.
2. Check that vinyl silver trap scrapping ring is in place and properly seated over throat opening in cone or sink.
3. Turn disposer ON. Note that water is flowing into top cone or into sink via the water swirl fitting.



WARNING: Never feed waste by hand past vinyl silver trap ring or reach inside running disposer.

NOTE: Do not feed metal, wood, cloth, rubber, corn husks, plastics, plastic sheets of bags, styrofoam, or other foreign matter. A periodic clean out of such material from the disposer is advisable.

4. Proceed with dish cleanup, feeding waste gradually. DO NOT pack waste into disposer waste chamber.
5. After each use, if disposer is wired with manual controls, allow disposer to run (motor and water) for at least 2 minutes. This clean-out cycle will empty the disposer and flush the waste line, preventing potential drain stoppage.
6. Should motor stop during use cycle, SHUT OFF POWER IMMEDIATELY, via ON-OFF switch. If disposer is connected to Model RAC2 Control Center, shut OFF power at black emergency disconnect handle; on manual switches, turn branch circuit disconnect to OFF.
 - A. Remove vinyl silver saver scrapping ring and check waste chamber through top opening and remove foreign objects that may have caused stoppage.
 - B. Check to see if rotor turns freely.
 - C. If rotor turns freely, replace vinyl silver saver scrapping ring and turn disposer ON.

If disposer fails to start and run, an obstruction may still be binding the rotor.

- A. Turn disposer OFF. Using a wooden bar or wooden handle, pry and push against the impact bars on the rotor to break it free; then remove object.
- B. Turn disposer ON and if motor fails to start, the thermal protector, either in the motor ("H" and "A" Series) or in the controls, may have tripped.
- C. Push reset button on thermal protector.

If disposer still fails to start, check for blown fuses or tripped circuit breakers in the branch circuit (especially on three-phase installations) to be sure that all power legs are feeding motor.

TROUBLESHOOTING

DISPOSER DOES NOT START WHEN NEW

Manual reset button of thermal protector is tripped. On "I" and "N" Series, reset button is on motor; on "S" and "G" Series, reset button is in control box.

Fuses or circuit breaker on branch circuit feed line have tripped.

Electrical connection on motor, in panel or feed lines not tight.

Headers have not been installed in starter, if starter is used in circuit.

DISPOSER DOES NOT START AFTER STANDING UNUSED FOR A PERIOD OF TIME

Clean out cycle too short. When disposer is stopped too early, the remaining water slowly drains out carrying the shattered waste particles into the very close clearance opening between sizing ring and rotor, where it hardens and solidifies, acting as a binding agent between the two parts. The motor at start-up is unable to overcome the dried blockage (usually on low horsepower disposers).

DISPOSER STALLS WHEN IN OPERATION

Large quantities of foreign material (rags, wood pieces, rubber bands, strings, pieces from floor mops, cellophane and polyethylene) which will not disintegrate, cause the motor to overheat and the thermal protector to trip.

Not enough water volume flow (GPM) causing thermal protector to trip.

Thermal protectors (heaters) sized too small, causing nuisance tripping.

TROUBLESHOOTING (continued)

DISPOSER OPERATES BUT DISINTEGRATION AND DISCHARGE IS SLOW

- Not enough water volume flow (GPM).
- Worn shattering mechanism (impact bars, sizing ring, rotor).
- Large amounts of foreign material in waste chamber.

DISPOSER MOVES WHEN STARTED

- Large amounts of unshattered waste in chamber.
- Rotor unbalanced due to loose impact bar.
- Disposer not anchored to floor.

DRAIN LINE CLOGS

- Worn shattering mechanism (impact bars, sizing ring, rotor) permitting large waste particles to flow through.
- Large amount of paper and non-food particles being fed into disposer.
- Not enough water volume flow (GPM).

DISPOSER DOES NOT TURN OFF (AFTER CLEAN OUT CYCLE, IF WIRED WITH RAC2)

- Stop button in switch or control defective.
- Timer in Model RAC2 control center defective.

DISPOSER DOES NOT REVERSE

- Contacts in manual reversing switch burned.
- Contact in auto reversing control center defective.
- Reversing circuit in auto reversing control center defective.
- Time lapse safety circuit in auto reversing control center defective.
- Motor not wired as indicated in wiring diagram.

SEVERE VIBRATION DURING OPERATION

- Loose or broken impact bars.
- Unshattered waste lodged in rotor.
- Severe rotor damage from metal objects being fed into disposer.

MOTOR RUNS BUT NO WATER FLOW

- Solenoid valve improperly wired.
- Defective solenoid valve coil.
- No water flow in main feed line.

MOTOR NUT TURNING AT PROPER RPM

- Low voltage on incoming feed line.
- On three-phase hookups, no voltage on one feeder line (leg).
- Motor not wired as indicated in wiring diagram (low to high, high to low voltsO).

LOUD NOISE FROM MOTOR AREA

- Upper or lower or both bearings worn.
- Leakage of disposer seals.

SMOKE OR BURNING ODOR FROM MOTOR

- Incoming voltage not correct.
- On three-phase hookups, no voltage on one feeder line (leg).
- Water leaking into motor through faulty seals.
- Disposer being overloaded, especially with foreign material.
- Improper motor connections.

TROUBLESHOOTING (continued)

MOTOR BURNS OUT

- Internal winding short.
- Water leaking into motor through faulty seals.
- Disposer being overloaded.
- Incoming voltage not correct.
- Thermal protectors (heaters) not tripping, sized too large.

WATER LEAKING FROM BASE OR DISPOSER

- Defective seals.
- Hole worn in base.
- Motor mounting screws not sealed on "I" and "N" Series units.
- Leaking plumbing connections or leaking sink mounts.

WATER SPLASHING UP FROM DISPOSER

- Building water pressure too high.
- Globe valve not installed or needs adjustment.

WATER FLOWS BUT MOTOR DOES NOT RUN

- Thermal protectors (heaters) not installed in starter.
- Motor not wired as indicated on wiring diagram.
- Control not wired correctly.

MAINTENANCE

Waste disposer troubles usually involve plumbing. A preventative maintenance program is advisable to keep waste line stoppage and disposer repair at a minimum. Any sewer problem occurring shortly after your disposer has begun operation cannot be caused by the new machine. It will be the result of connecting to either an inadequate waste line, or to one that has not been properly cleared before use. On the other hand, if waste line clogging occurs after the disposer has been running trouble-free for a year or more, this indicates probable need for servicing.

The slurry leaving a new disposer contains no discernible solids, so there is nothing to clog the waste line. In regular use, however, wearing of the working parts is to be expected. As the gradual wear occurs, the solid particles passing through the wider gaps in the shatter mechanism will grow increasingly larger, until waste line stoppage may result. See Figures.

MONTHLY WEAR CHECK

NOTE: The following should be performed every two weeks if waste is of a highly abrasive consistency.

1. Shut OFF branch circuit power, or emergency disconnect on control panel when disposer has completed its clean out cycle.
2. Loosen stainless steel clamps on neoprene connector sleeve.
3. Twist neoprene sleeve loose and remove.
4. On "S" and "G" Series, loosen Quick-Release body clamps and lift off aluminum lid.
5. Remove any foreign objects (rubber bands, metal, wood, plastics, etc.) from waste chamber.
6. Check free movement of rotor.
7. The two points of probable wear are the leading edges of the impact bars and the spacing between the outer edges of the rotor and the inner diameter of the sizing ring teeth (Figure 1, Page 13). When one end of each impact bar is worn rounded, as shown in Figure 2, Page 13, they need to be reversed (if disposer is wired to an automatic reversing control).
 - A. Loosen four hex socket head cap Allen screws to release the bars. Should it be necessary, use liquid wrench or a mixture of oil and kerosene to help loosen the screws.

MAINTENANCE (continued)

B. Reverse bars and reinstall Allen screws.

C. When the edges of the reversed impact bars become rounded (Figure 3), the bars must be replaced. See below and Page 14.

8. The second point of wear is the clearance between the outer edge of the rotor and the inner diameter of the sizing ring teeth (Figure 3).

If the space between the rotor and sizing ring has grown to $\frac{3}{32}$ " (.094) and the impact bars are worn (rounded) as shown in Figure 3, replacement of total rotor and sizing ring is advisable. See below and Page 14.

NOTE: If $\frac{3}{32}$ " space between rotor and sizing ring is left to continue to increase, waste line stoppage may result as increasingly large whole sections of waste will pass through sizing ring without breaking up.

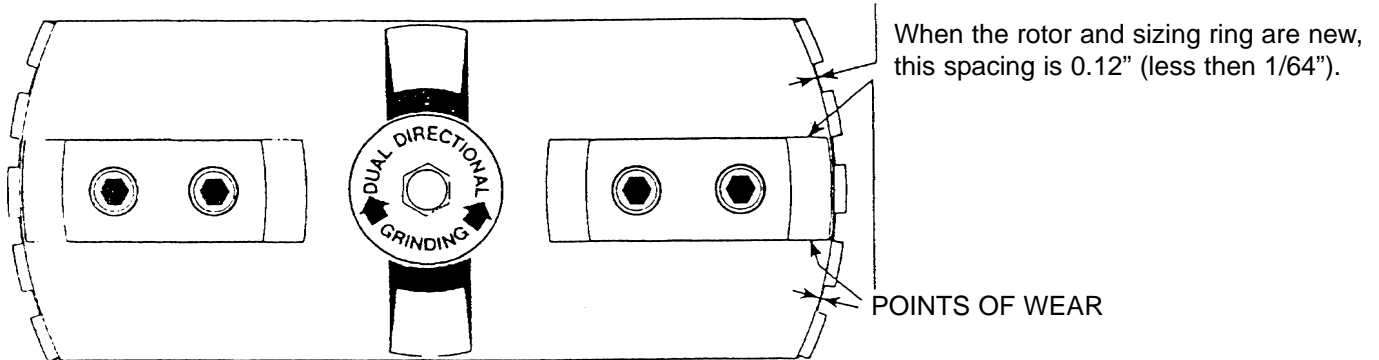
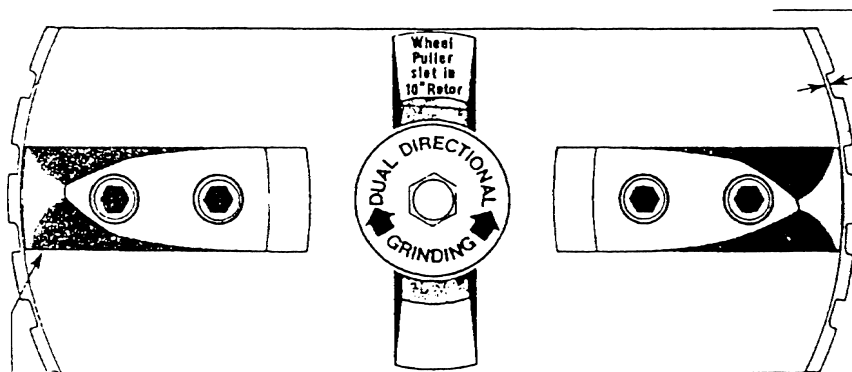

FIG. 1



These bars are badly worn and need reversing.
Remove Allen screws and reverse bars.

FIG. 2

When these impact bars are reversed, presenting new working sides, this disposer will function well even though this space may have grown to $\frac{3}{32}$ ".

At this stage of wear, no new parts are needed.

With uniform wear on the rotor and the teeth, spacing between has increased, but the new faces of the reversed bars restore efficiency.

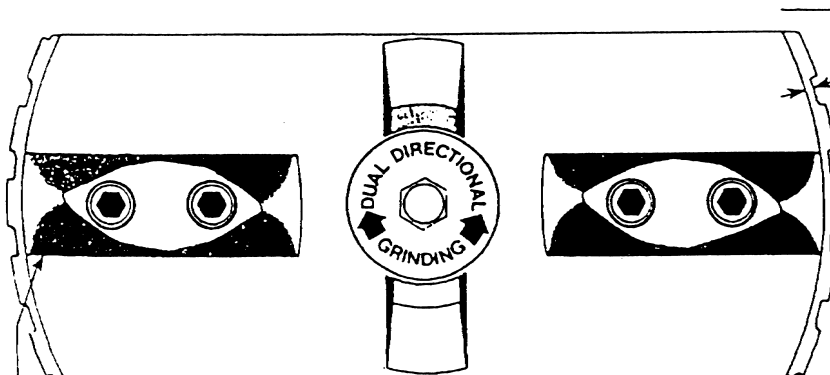

These bars have had their double life.

FIG. 3

With both sides well worn, it is evident that this disposer was properly cared for, getting maximum length of service from all parts.

At this stage of double wear on bars, this space may be $\frac{3}{32}$ " (.094). Check with feeler gauge or U.S. Std. #13 gauge wire.

At this stage, bars only may be renewed—provided spacing between rotor and teeth has not grown to $\frac{3}{32}$ " and if waste line appears capable of handling the slurry output.

PARTS REPLACEMENT



WARNING: ALWAYS SHUT OFF MAIN POWER DISCONNECT BEFORE PERFORMING MAINTENANCE OR PARTS REPLACEMENT.

IMPACT BARS (Series N, S and G)

1. Shut off main power disconnect.
2. Disconnect water line feeding into waste chamber, if applicable.
3. Loosen stainless steel clamps and remove neoprene sleeve.
4. On Series "N" disposers, remove 4 1/2" or 7" waste chamber by loosening and removing the six hex head bolts holding chamber to base.
On Series "S" and "G" disposers, remove aluminum lid by loosening quick-release head clamps.
5. Insert wedge at impact bar between rotor and sizing ring to prevent rotor rotation.
6. Loosen hex socket head cap Allen screws and remove impact bars. Use liquid wrench or a solution of oil and kerosene if necessary.
7. Install new impact bars in milled slots, after cleaning slots of foreign materials. Be sure new bars fit tightly into slots and sit flatly, making metal to metal contact.
8. Remove anti-rotation wedge.
9. Replace removed components and reconnect disposer to sink or dishtable.

ROTOR AND/OR SIZING RING

1. Shut off main power disconnect.
2. Disconnect water line feeding into waste chamber, if applicable.
3. Loosen and disconnect disposer from sink or dishtable.
4. Remove waste chamber by loosening and removing the hex head bolts holding chamber to base.
5. Remove center cover bolt and plate.
6. Remove the two centering hold down studs from sizing ring and lift off sizing ring.
7. Remove old gaskets from base sizing ring or waste chamber.
8. Lift off rotor. On "S" and "G" Series, provisions for use of a wheel puller are cast into rotor. When using wheel puller, thread back cover bolt onto motor shaft 1/2". This will protect the threaded motor shaft.
9. Remove key from shaft.
10. Clean and inspect keyway.
11. Inspect motor seal system. If replacement is necessary, do so now. See Instructions on Page 13.
12. Oil motor shaft and slide on new rotor. Be sure rotor has seated fully on motor shaft shoulder and that shaft is below machined surface on rotor.
13. Reinsert key. Series "S" and "G" use two keys. BE SURE the keys make metal to metal contact on all surfaces in the rotor and motor shaft keyways and that the key is the full length of the keyway. Short keys will shear at peak loads. Rotate rotor slightly to be sure there is no radial play between the rotor and motor shaft.
14. Insert cover gasket, plate and bolt to lock down rotor.
15. Torque cover bolt to 34 ft-lbs.
16. Install one new gasket on base.
17. Place sizing ring over gasket on base and thread in new centering studs.
18. Center sizing ring on rotor, turning rotor several complete turns. There should now be approximately 1/64" running clearance between rotor and sizing ring.
19. Lock sizing ring into place with the centering studs. BE SURE sizing ring did not move and that running clearance has been maintained.
20. Place the second gasket over centering studs and install waste chamber.
21. Lock waste chamber into place and reconnect parts removed earlier.

PARTS REPLACEMENT (continued)

MOTOR SEALS AND/OR MOTOR

1. Shut off main power disconnect.
2. Disconnect disposer from dishtable and waste line; remove floor mount and disconnect electric line feeding motor.
3. Slide out disposer.
4. Remove rotor and sizing ring, as described on Page 14.
5. Series "I" and "N": Remove four (4) motor bolts.
Series "I" and "N": Turn disposer over resting base, especially sizing ring clamping surface, on wooden blocks.
6. Series "S" and "G": Remove four (4) motor bolts and lift off motor.
Series "S" and "G": Drive out the lip seal and cartridge seal; clean seal seating area.
Series "S" and "G": Turn base over and set in the new lip seal (open side of seal facing up) and oil with SAE 30 oil.
7. Install cartridge seal.
 - A. Place light application of Permatex adhesive gasket sealant or equivalent in seal bore in base.
 - B. Fully immerse new cartridge seal in SAE 30 oil.
 - C. Install new cartridge seal (rubber seal ring up), using installation tool (available separately) making sure seal is fully seated in bore.
8. Turn base back onto the wooden blocks.
9. Clean motor shaft and oil shaft well with SEA 30 oil.
10. Slide motor back over seals and fasten motor. BE SURE motor is in same position as before for electrical connections.
11. Turn base with motor back over and make sure rubber seal ring on cartridge seal is in place.
12. Re-install components, as listed on Page 14 and reconnect disposer.

"I" SERIES REPLACEMENT PARTS LIST

KEY NO.	PART NO.	NAME: DESCRIPTION	QTY. PER MACH.	KEY NO.	PART NO.	NAME: DESCRIPTION	QTY. PER MACH.
1	30-H-RSA	RSA Head Assy	1	28	30-A-436-524	Motor: 1.5 HP, 3PH.....	1
		(includes 2-9)				(includes 19-21 & 28)	
2	06-H-8	Sink Stopper: "H" Series RSA	1	29	02-H-462	Thermal Protector: #MWJ57KB.....	1
3	27-H-15	Sink Mount: Threaded	1				
4	07-H-19	Gasket: RSA Rubber	1	28	30-A-480	Motor: 2 HP, 1PH.....	1
5	07-H-20	Gasket: RSA Fiber.....	1			(includes 19-21 & 28)	
6	08-H-21	Screw, Hxhd 5/16-18 x 3/4	6	29	02-H-463	Thermal Protector: #CWJ54KF	1
7	08-HA-311	Washer: Lock Split 5/16.....	13	30	02-A-332	Capacitor: 590-708MF, 120V.....	1
8	51-H-17	RSA Head.....	1		02-5-487	Capacitor: 50MF, 240V	1
9	07-H-18	Gasket: Splash Guard	1	28	30-A-437	Motor: 2 HP, 3PH.....	1
10	06-HA-ST4	Silver Saver: 4 1/2".....	1			(includes 19-21 & 28)	
11	07-H-34	Gasket: "H" Series Cone	1	29	02-5-486	Thermal Protector: #BEJ44DB	1
12	08-HA-22	Screw: Hxhd 5/16-18 x 1, SS.....	4				
13	51-H-12LD	Drum.....	1	31	06-5-505	Rubber Boot: Thermal Protector	1
14	08-HA-17	Nut: Hex 6116-18.....	2	32	30-HA-506	Conduit Box Assy	1
15	10-5-27	Pipe Plug: 1/2".....	1	33	08-HA-282	Key: Woodruff 1606.....	1
16	07-H10	Gasket: Sizing Ring.....	2	34	02-HA-521	V-Ring Seal.....	1
17	08-HA-16	Centering Stud.....	2	35	02-HA-522	Seal: Motor Shaft, "H" & "A" Series	1
18	30-HD-9D	Sizing Ring	1	36	02-5-400	Bearing: #205	1
19	08-6-276	Nut: Hex Jam Nyloc, 5/8 x 18, SS.....	1	37	02-HA-508	Capacitor Housing.....	1
20	08-6-277	Washer: Flat, H D.5/8 x .134 thick	1	38	02-HA-520	Clamp: Fan	1
21	07-6-98	Gasket: Turntable Mounting	1	39	02-H-466	Fan, Ext: Leeson 145 Frame.....	1
22	30-H-1-D	Rotor: With Cast-On Impact Bars.....	1	40	02-H-467	Fan Guard: Leeson 145 Frame	1
23	07-HA-83	Cartridge Seal.....	1	41	08-SN-1219	Bearing: #203	1
	04-HA-263	Install. Tool: HA Cartridge Seal.....	1	42	02-H-016	Cast Endshield "H" Leg Kit.....	1
24	08-5-24	Screw: Skhd 3/8-16 x 3/4 Nyloc SS....	4	43	08C-1093	Nut: Hex 1/2" - 13.....	1
25	30-H-1140	Base Assy: Includes Seals Installed....	1	44	08-C-1095	Washer: Lock Split 1/2"	1
26	06-5-849	Drain Coupling: "H" Series	1	45	04-H-287	Mounting Plate "H" Leg Kit	1
27	07-HA-5	Gasket: Motor/Base.....	1	46	09-A-931	Leg Assembly "H" Series.....	1
28	30-H-431	Motor: 3/4 HP, 1PH.....	1	47	080-MM-2255	Screw.....	1
		(includes 19-21 & 28)		48	08-BC-312	Washer, Lock Split 3/8"	1
29	02-H-479	Thermal Protector.....	1				
30	02-MC-7500	Capacitor: 540-648MF, 120V.....	1				
28	30-H-432	Motor: 3/4 HP, 1PH.....	1		40-H-504	A-Complete Renewal Kit	1
		(includes 19-21 & 28)				(S/N 060185H01 forward)	
29	02-H-326	Thermal Protector: #MWJ69KB.....	1		40-H-500	H-Complete Renewal Kit	1
						(Thru S/N 060185h29)	
28	30-H-523	Motor: 1 HP, 1PH.....	1		40-H-1DA	H-Rotor Kit (includes 19-22).....	1
29	02-MC-6068	Thermal Protector: #CEJ53CB.....	1		40-H-9DA	H-Sizing Ring Kit	1
30	02-MC-7500	Capacitor: 540-648MF, 120V.....	1			(includes 14-17 & 16-18)	
28	30-H-524	Motor: 1 HP, 3PH.....	1		40-HA-507	H-Motor Seal Kit (includes 23 & 27)....	1
		(includes 19-21 & 28)				(S/N 060185H011 forward)	
29	02-H-303	Thermal Protector: #MWJ66KB.....	1		40-HA-12A	H-Motor Seal Kit.....	1
						(Thru S/N 060185H011)	
28	30-H-433	Motor: 1.25 HP, 1PH.....	1	***	08-HA-23	Screw: Hxhd 5/16 x 3/4 SS Nyloc.....	1
		(includes 19-21 & 28)		***	09-HA-2	Coverplate	1
29	02-H-326	Thermal Protector: #CEJ50CA.....	1	***	07-HA-3	Gasket: Coverplate.....	1
30	02-MC-7500	Capacitor: 540-648MF, 120V.....	1	***	02-HA-100	Key	1
28	30-H-434	Motor: 1.25 HP, 3PH.....	1				
		(includes 19-21 & 28)		***	PARTS FOR OLD STYLE DISPOSERS		
29	02-H-460	Thermal Protector: #MWJ64KB.....	1				
28	30-H-435	Motor: 1.5 HP, 1PH.....	1				
		(includes 19-21 & 28)					
29	02-MC-6070	Thermal Protector: #CEJ38CA.....	1				
30	02-A-477	Capacitor: 460-552MF, 120V.....	1				
	02-A-476	Capacitor: 17.5MF, 240V	1				

"I" SERIES REPLACEMENT PARTS DIAGRAM

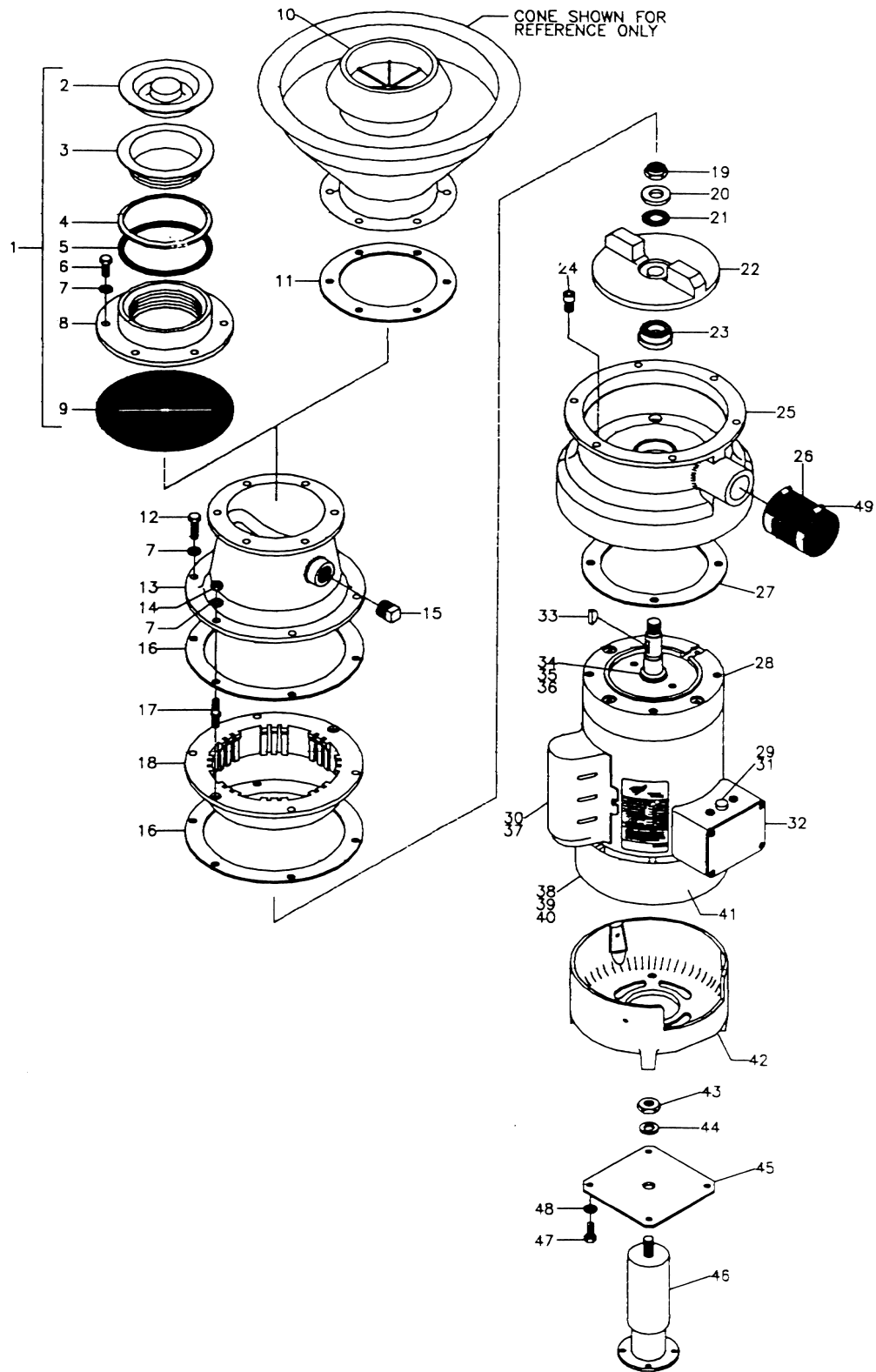

“N” SERIES REPLACEMENT PARTS LIST

KEY NO.	PART NO.	NAME: DESCRIPTION	QTY. PER MACH.	KEY NO.	PART NO.	NAME: DESCRIPTION	QTY. PER MACH.
1	06-HA-ST4	Silver Saver: 4 1/2".....	1	23	30-A-437	Motor: 2 HP, 3PH.....	1
	06-ABC-ST7	Silver Saver: 7".....	1			(includes 14-16 & 23)	
2	06-A-818	Connector Sleeve: 4 1/2" dia. x 8".....	1	24	02-A-463	Thermal Protector: #CWJ54KF.....	1
	06-A-414	Connector Sleeve: 4 1/2" dia. x 4".....	1		02-A-465	Thermal Protector: #CWJ58KX.....	1
	06-ABC-834	Connector Sleeve: 7" dia. x 8".....	1	26	02-5-400	Bearing: #205.....	1
	06-ABC-434	Connector Sleeve: 7" dia. x 4".....	1	27	08-SM-1219	Bearing: #203.....	1
3	08-A-19	Clamp: Connector Sleeve 4 1/2".....	2				
	08-ABC-33	Clamp: Connector Sleeve 7".....	2	23	30-A-438	Motor: 3 HP, 3PH.....	1
4	51-A-11AS	Drum: 4 1/2" Throat.....	1			(includes 14-16 & 23)	
	51-A-11S	Drum: 7" Throat.....	1	24	02-A-464	Thermal Protector: #BYJ36KF.....	1
	51-A-81	Offset Drum: 7" Throat.....	1	26	02-BC-401	Bearing: #206.....	1
5	08-HA-22	Screw: Hxhd 5/16-18 x 1, SS.....	4	27	08-SM-1418	Bearing: #204.....	1
6	08-HA-311	Washer: Lock Split 5/16.....	7				
7	08-HA-17	Nut: Hex 5/16-18.....	2	23	30-A-481	Motor: 5 HP, 3PH.....	1
8	10-5-27	Pipe Plug: 1 1/2".....	1			(includes 14-16 & 23)	
9	07-A-10	Gasket: Sizing Ring.....	2	29	02-A-523	Seal: V-Ring 5HP Leeson.....	1
10	08-HA-16	Centering Stud.....	2	30	02-A-524	Seal: Motor Shaft 5 HP Leeson.....	1
11	*30-A-9	Sizing Ring.....	1				
12	08-5-24	Screw: Skhd 3/8-16 x 3/4 Nyloc SS.....	6	24	02-A-488	Thermal Protector: #BYJ32KB.....	1
13	*30-A-27	Impact Bar.....	2	26	02-BC-401	Bearing: #206.....	1
14	08-6-276	Nut: Hex Jam Nyloc, 5/8-18, SS.....	1	27	08-SM-1418	Bearing: #204.....	1
15	08-6-277	Washer: Flat, HD, 5/8 x .134 thick.....	1				
16	07-6-98	Gasket: Turntable Mounting.....	1	28	08-HA-282	Key, Woodruff: #606.....	1
17	*51-A-1	Rotor.....	1	29	02-HA-521	V-Ring Seal.....	1
	*30-A-1	Rotor Assy: w/Impact Bars.....	1	30	02-HA-522	Seal: Motor Shaft, "H" & "A" Series.....	1
		(includes 12, 13 & 17)		31	02-HA-508	Capacitor Housing.....	1
18	08-5-24	Screw: Skhd 3/8-16 x 3/4 Nyloc SS.....	4	32	06-5-505	Rubber Boot: Thermal Protector.....	1
19	07-HA-83	Cartridge Seal.....	1	33	30-HA-506	Conduit Box Assy.....	1
	07-HA-263	Install. Tool: HA Cartridge Seal.....	1	34	09-A-928	Leg Assy w/Foot: 2" x 13.5, SS.....	3
20	30-A-1141	Base Assy: Includes Seals Installed.....	1	35	09-ABC-930	Foot, Flanged: SS.....	1
21	06-5-851	Drain Coupling: "A" & "B" Series.....	1	36	02-HA-520	Clamp: Fan.....	1
22	07-HA-5	Gasket: Motor/Base.....	1	37	02-H-466	Fan, Ext: Leeson 145 Frame.....	1
					02-A-474	Fan: Leeson 180 Frame.....	1
23	30-A-435	Motor: 1.5 HP, 1PH.....	1	38	02-H-467	Fan Guard: Leeson 145 Frame.....	1
		(includes 14-16 & 23)			02-A-473	Fan Guard: Leeson 180 Frame.....	1
24	02-MC-6070	Thermal Protector: #CEJ38CA.....	1		40-A-500	A-Complete Renewal Kit.....	1
25	02-A-477	Capacitor: 460-552MF, 120V.....	1			(Thru S/N 053185A02)	
	02-A-476	Capacitor: 17.5MF, 240V.....	1		40-A-503	A-Complete Renewal Kit.....	1
26	02-5-400	Bearing: #205.....	1			(S/N 060185H01 forward)	
27	08-SM-1219	Bearing: #203.....	1		40-A-1A	A-Rotor Kit.....	1
					40-A-9A	A-Sizing Ring Kit.....	1
23	30-A-436	Motor: 1 HP, 3PH.....	1		40-HA-507	H-Motor Seal Kit.....	1
		(includes 14-16 & 23)				(S/N 060185H01 forward)	
24	02-A-462	Thermal Protector: #MWJ57KB.....	1		40-HA-12A	H/A-Motor Seal Kit.....	1
26	02-5-400	Bearing: #205.....	1			(Thru S/N 053185A02)	
27	08-SM-1219	Bearing: #203.....	1	***	08-HA-23	Screw: Hxhd 5/16 x 3/4 SS Nyloc.....	1
				***	09-HA-2	Coverplate.....	1
23	30-A-480	Motor: 2 HP, 1PH.....	1	***	07-HA-3	Gasket: Coverplate.....	1
		(includes 14-16 & 23)		***	02-HA-100	Key.....	1
24	02-5-486	Thermal Protector: #BEJ44DB.....	1				
25	02-A-332	Capacitor: 590-708MF, 120V.....	1	***	PARTS FOR OLD STYLE DISPOSERS		
	02-A-487	Capacitor: 50MF, 240V.....	1				
26	02-5-400	Bearing: #205.....	1				
27	08-SM-1219	Bearing: #203.....	1				

"N" SERIES REPLACEMENT PARTS DIAGRAM

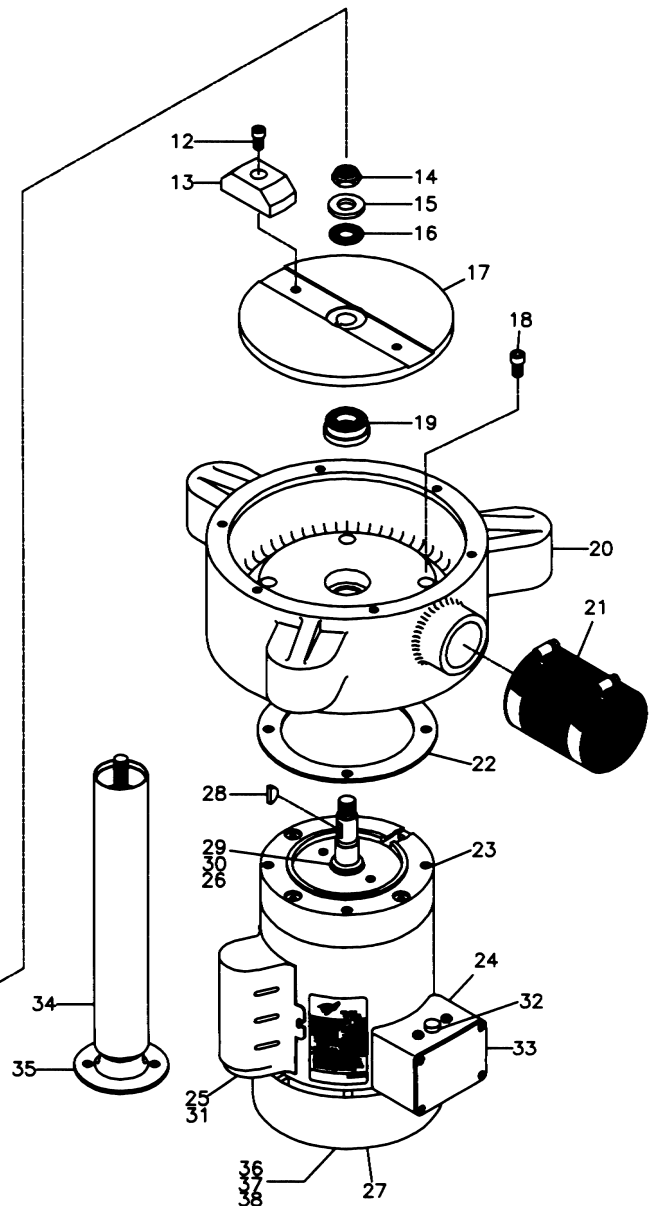
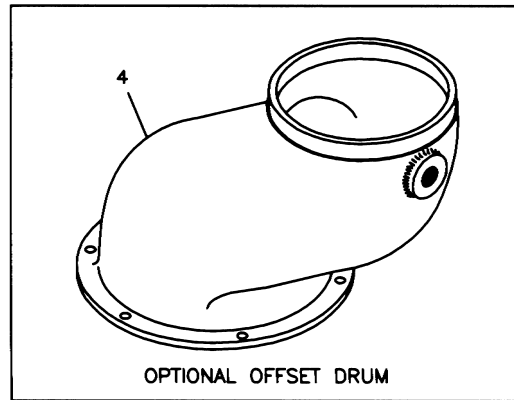
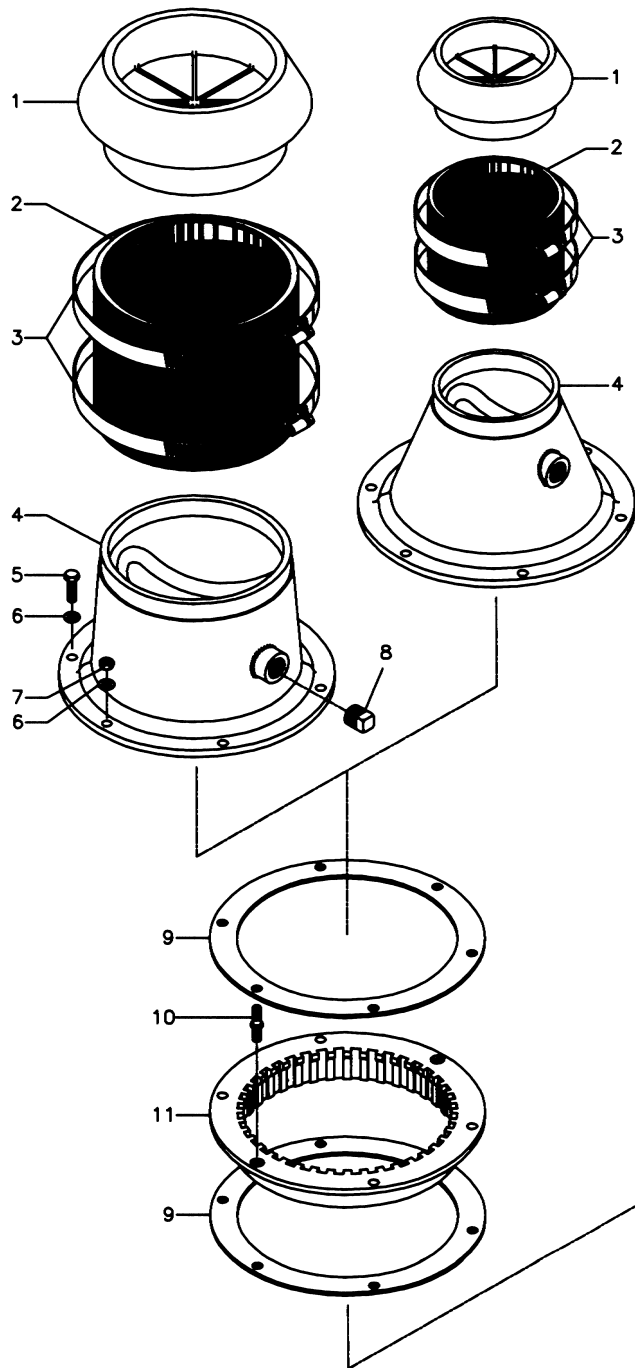

“S” SERIES REPLACEMENT PARTS LIST

KEY NO.	PART NO.	NAME: DESCRIPTION	QTY. PER MACH.	KEY NO.	PART NO.	NAME: DESCRIPTION	QTY. PER MACH.
1	06-ABC-ST7	Silver Saver: 7"	1		30-BC-151	Motor: 5 HP, 3PH Baldor	1
2	06-ABC-834	Connector Sleeve: 7" dia. x 8".....	1			(includes 19-21 & 28)	
	06-ABC-434	Connector Sleeve: 7" dia. x 4".....	1		02-BC-470	Rotor & Shaft Assy: 5 HP Baldor.....	1
3	08-ABC-33	Clamp: Connector Sleeve 7"	2				
4	01-B-36L	Lid: 7" Aluminum.....	1		30-BC-161	Motor: 7.5 HP, 3PH Baldor	1
5	07-B-39	Gasket: Lid	1			(includes 19-21 & 28)	
6	51-B-36	Drum.....	1		02-BC-469	Rotor & Shaft Assy: 7.5 HP Baldor.....	1
	51-B-80	Offset Drum	1				
	30-B-36	Drum Assy (includes 6 & 10-12.....	1				
7	08-BC-71	Screw: Hxhd 3/8-16 x 1-1/2.....	6		30-C-171	Motor: 10 HP, 3PH Baldor	1
8	08-BC-312	Washer: Lock Split 5/16.....	13			(includes 19-21 & 28)	
9	08-BC-1029	Nut: Hex 3/8-16	6		02-C-468	Rotor & Shaft Assy: 10 HP Baldor.....	1
10	08-BC-67	Thumb Screw: Lid Clamp.....	4				
11	51-BC-65	Lid Clamp	4	28	02-BC-472	End Plate, Upper: Baldor 3-10 HP	1
12	08-BC-285	Screw: Hxhd 3/8-15 x 1-1/2.....	4	29	08-BC-72	Screw: ckt Hd 3/8-16 x 1	4
13	07-B-32	Gasket: Sizing Ring.....	2	30	08-HA-283	Key, Woodruff: #808	1
14	08-BC-1028	Centering Stud.....	2	31	07-B-14	Lip Seal.....	1
15	30-B-31	Sizing Ring	1		07-BC-903	Lip Seal: 1 7/8" OD Baldor	1
16	10-5-27	Pipe Plug: 1/2".....	1		07-WM-0066	Seal: V-Ring Baldor	1
17	08-5-24	Screw: Skhd 3/8-16 X 3/4, Nyloc SS ..	4	32	02-BC-403	Bearing: #306	1
18	30-B-6	Impact Bar	2	33		Conduit Box Assy: Baldor N/A.....	1
19	08-6-280	Nut: Hex Jam Nyloc, 7/8-14, SS	1	34	02-BC-465	End Plate, Lower: Baldor 3-10 HP	1
20	08-6-281	Washer: Flat, HD, 7/8 x .134 thick	1	35	02-BC-401	Bearing: #206	1
21	07-BC-99	Gasket: Turntable Mounting	1	36	09-BC-927	Leg Assy w/Foot: 2" x 9.6, SS.....	3
22	51-B-1	Rotor.....	1	37	09-ABC-930	Foot, Flanged: SS	3
	30-B-1	Rotor Assy: w/Impact Bars	1				
		(includes 17, 18 & 22)			40-B-501	B-Complete Renewal Kit	1
23	07-BC-84	Cartridge Seal.....	1			(S/N 060185B01 forward)	
	04-BC-2634	Install. Tool: BC Cartridge Seal	1		40-A-500	B-Complete Renewal Kit	1
24	07-B-14	Lip Seal.....	1			(Thru S/N 053185B05)	
25	30-B-1142	Base Assy: Includes Seals Installed....	1		40-B-1A	B-Rotor Kit (includes 17-22)	1
26	06-5-851	Drain Coupling: "A" & "B" Series	1		40-B-31A	B-Sizing Ring Kit	1
						(includes 8-9 & 13-15)	
27	30-B-141	Motor: 3 HP, 3PH Baldor	1		40-B-502	B-Motor Seal Kit (includes 23-24)	1
		(includes 19-21 & 28)				(S/N 060185B01 forward)	
	02-B-471	Rotor & Shaft Assy: 3 HP Baldor.....	1		40-B-12A	B-Motor Seal Kit	1
						(Thru S/N 053185B05)	
				***	08-BC-25	Screw: Hxhd 3/8 - 16 X 1 SS Nyloc	1
				***	09-B-4	Coverplate	1
				***	07-B-5	Gasket: Coverplate.....	1
				***	02-BC-200	Key	1

"S" SERIES REPLACEMENT PARTS DIAGRAM

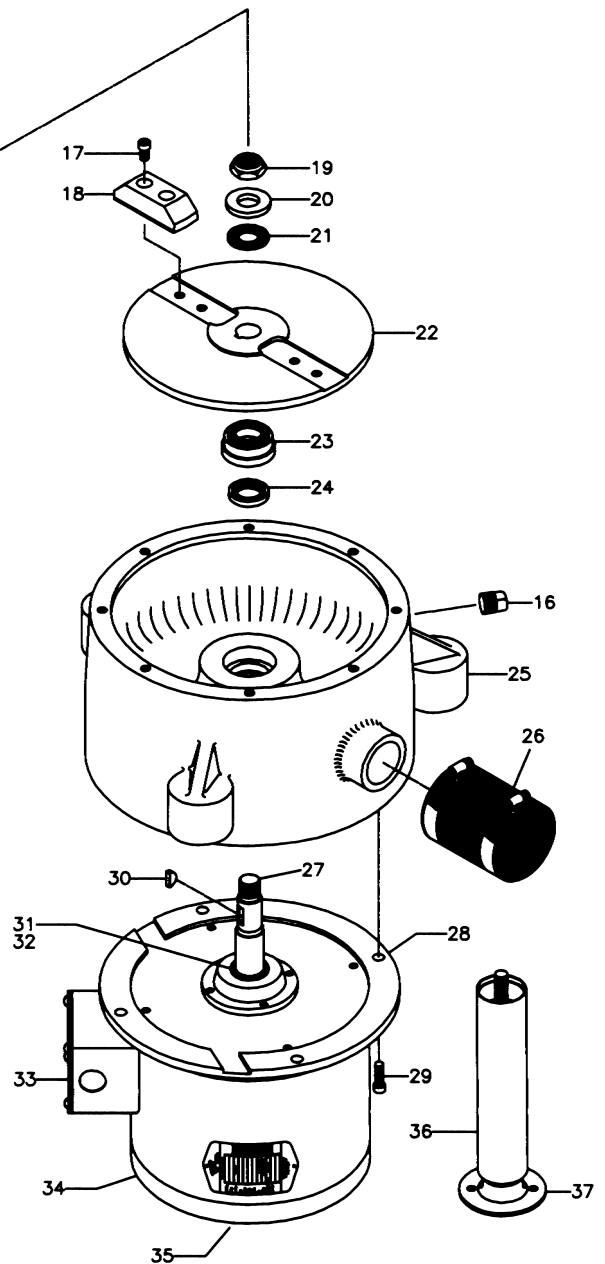
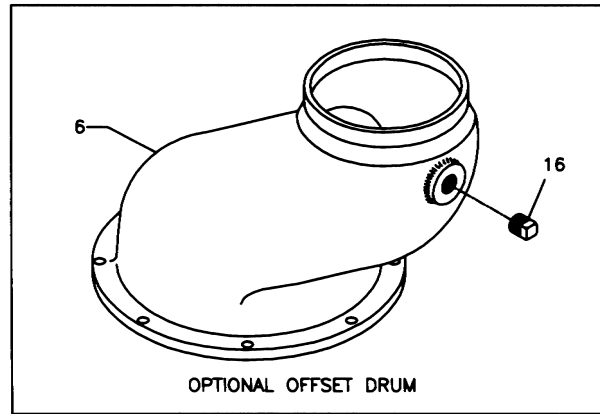
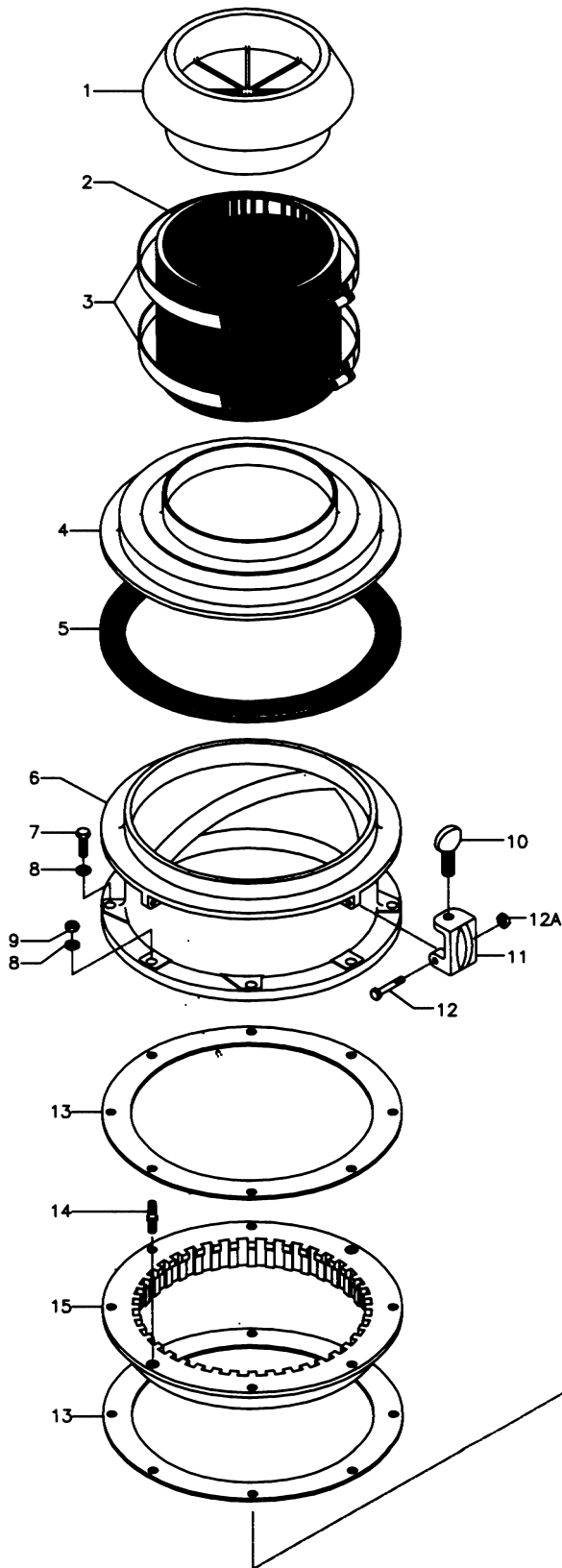

“G” SERIES REPLACEMENT PARTS LIST

KEY NO.	PART NO.	NAME: DESCRIPTION	QTY. PER MACH.	KEY NO.	PART NO.	NAME: DESCRIPTION	QTY. PER MACH.
1	06-ABC-ST7	Silver Saver: 7".....	1		30-BC-161	Motor: 7 HP, 3PH.....	1
2	06-ABC-834	Connector Sleeve: 7" dia. x 8".....	1			(includes 17-19 & 33)	
	06-ABC-434	Connector Sleeve: 7" dia. x 4".....	1		02-BC-469	Rotor & Shaft Assy: 7.5 HP Baldor.....	1
3	08-ABC-33	Clamp: Connector Sleeve 7".....	2		30-C-171	Motor: 10 HP, 3PH.....	1
4	01-C-1136	Lid: 7" Offset Opening.....	1			(includes 17-19 & 33)	
4A	07-C-1039	Gasket: Lid.....	1		02-C-468	Rotor & Shaft Assy: 10 HP Baldor.....	1
5	51-C-1036	Drum.....	1				
	51-C-1080	High Drum.....	1	27	08-BC-283	Key, Woodruff: #808.....	1
	51-C-80	Offset Drum.....	1	28	07-B-14	Lip Seal.....	1
	30-C-1036	Drum Assy (includes 9-11).....	1		07-BC-903	Lip Seal: 1 7/8" OD Baldor.....	1
6	08-BC-71	Screw: Hxhd 3/8-16 x 1-1/2.....	6		07-WM-0066	Seal: V-Ring Baldor.....	1
7	08-BC-312	Washer: Lock Split 3/8".....	13	29	02-BC-403	Bearing: #306.....	1
8	08-BC-1029	Nut: Hex 3/8-16.....	2				
9	08-BC-67	Thumb Screw: Lid Clamp.....	4	31	02-BC-465	End Plate, Lower: Baldor 3-10 HP.....	1
10	51-BC-65	Lid Clamp.....	4	32	02-BC-401	Bearing: #206.....	1
11	08-BC-285	Screw: Hxhd 1/4-20 x 1-3/4, SS.....	4				
11A	08-BC-286	Nut: Hex Nyloc, 1/4-20, SS.....	4	34	08-BC-72	Screw: Sckt Hd 3/8-16 x 1.....	4
12	07-C-1032	Gasket: Sizing Ring.....	2	35	09-BC-927	Leg Assy w/Foot: 2" x 9.6, SS.....	3
13	08-BC-1028	Centering Stud.....	2	36	09-ABC-930	Foot, Flanged: SS.....	3
14	30-C-1031	Sizing Ring Assy.....	1				
15	08-5-24	Screw: Skhd 3/8-16 x 3/4, Nyloc SS...4	4		40-C-505	C-Complete Renewal Kit.....	1
16	30-C-1006	Impact Bar.....	2			(S/N 060185C01 forward)	
17	08-6-280	Nut: Hex Jam Nyloc, 7/8-14, SS.....	1		40-C-500	C-Complete Renewal Kit.....	1
18	08-6-281	Washer: Flat, HD, 7/8 x .134 thick.....	1			(Thru S/N 053185C17)	
19	07-BC-99	Gasket: Turntable Mounting.....	1		40-C-1001A	C-Rotor Kit (includes 15-20).....	1
20	51-C-1001	Rotor.....	1		40-C-1031A	C-Sizing Ring Kit.....	1
	30-C-1001	Rotor Assy: w/Impact Bars.....	1			(includes 7-8 & 12-14)	
		(includes 15, 16 & 20)			40-C-1012A	C-Motor Seal Kit.....	1
21	07-BC-84	Cartridge Seal.....	1			(Thru S/N 053185C17)	
22	07-B-14	Lip Seal (S/N 010191 forward).....	1		40-B-502	B-Motor Seal Kit.....	1
	04-BC-264	Install. Tool: BC Cartridge Seal.....	1			(S/N 010191 forward)	
23	30-C-1143	Base Assy: Includes Seals Installed....	1	***	08-BC-25	Screw: Hxhd 3/8 - 16 X 1 SS Nyloc....	1
24	10-5-27	Pipe Plug: 1/2".....	1	***	09-C-1004	Coverplate.....	1
25	06-5-851	Drain Coupling: "C" Series.....	1	***	07-C-1005	Gasket: Coverplate.....	1
				***	02-BC-200	Key.....	1
26	30-BC-151	Motor: 5 HP, 3PH.....	1				
		(includes 17-19 & 33)					
	02-BC-470	Rotor & Shaft Assy: 5 HP Baldor.....	1				

"G" SERIES REPLACEMENT PARTS DIAGRAM

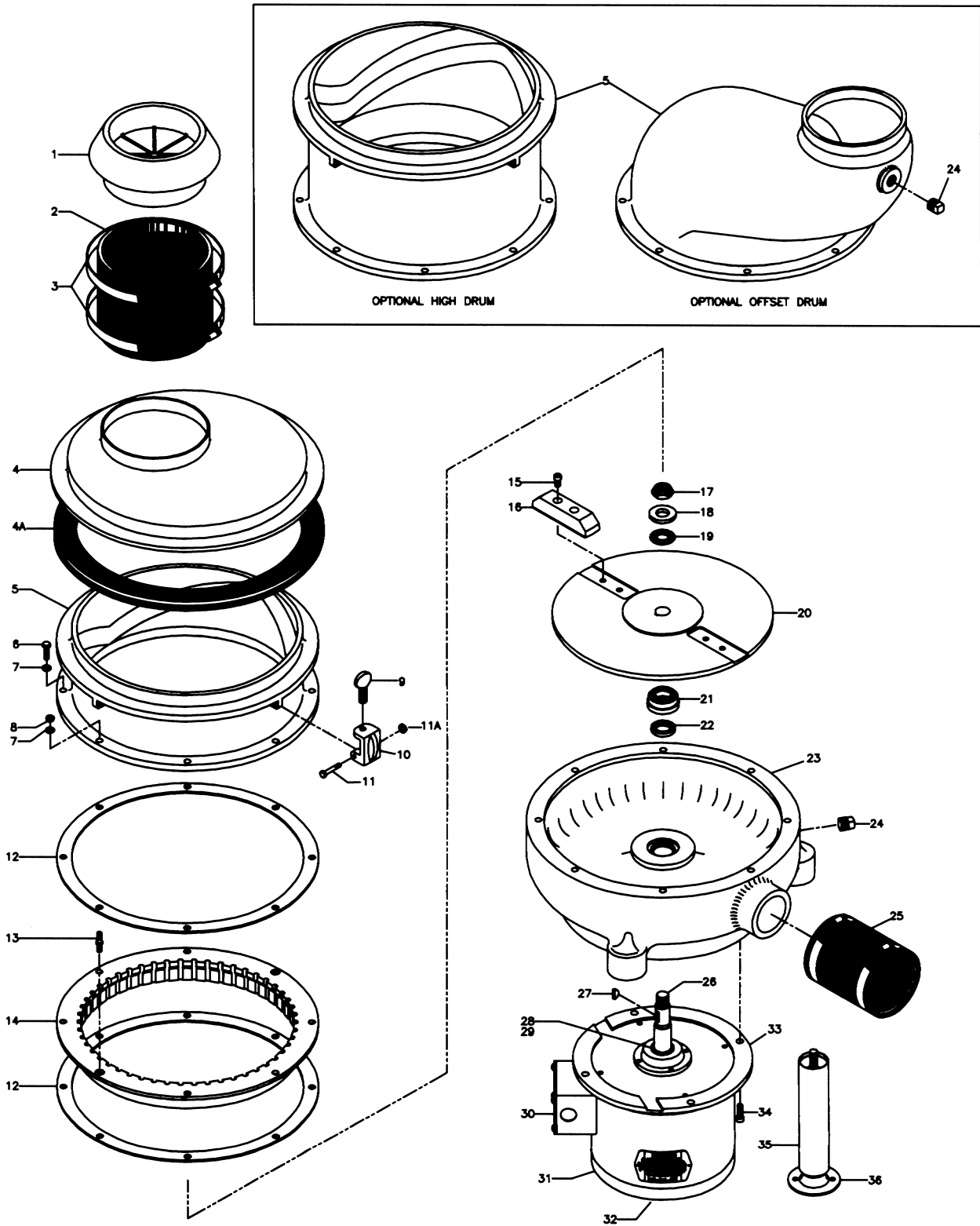

RAC1 & RAC1SS REPLACEMENT PARTS LIST

KEY NO.	PART NO.	NAME: DESCRIPTION	QTY. PER MACH.	KEY NO.	PART NO.	NAME: DESCRIPTION	QTY. PER MACH.
1	03-5-988	Pushbutton Assy: Red (N.C.)	1	13	08-5-949	Screw, Php HD, 10-32 x 1/2	4
2	03-5-987	Pushbutton Assy: Black (N.O.)	1	14	03-5-983	Base Plate: RAC1 & RAC2	1
3	03-5-1023	Legend Plate: "STOP"	1	15	03-5-1067	Track: Contactor Mounting	1
4	03-5-1025	Legend Plate: "RUN"	1	16	03-5-1097	Grounding Lug	1
5	03-5-1042	Enclosure: Non-Metallic, RAC1 & 2	1	17	03-5-1002	Terminal Strip: 9 Position	1
	03-5-1088	Enclosure: SS, RAC1	1		03-5-1001	Terminal Strip: 6 Position	1
	03-5-972	Latch: SS Enclosure Door	1		03-5-1085	Terminal Strip: 13 Position	1
	08-5-949	Screw: Php HD, 10-32 x 1/2	1	18	08-6-251	Screw, Php HD, Slf Tpg 8-32 x 3/4	4
6	03-5-1034	Control Module	1	19	03-BC-935	Overload Relay: 12-18 Amp	1
7	08-6-258	Screw: Php HD, Slf Tpg 8-32 x 1	2		03-B-936	Overload Relay: 5.5-8 Amp	1
8	03-5-1000	Wiring Harness: RAC1	1		03-C-937	Overload Relay: 17-25 Amp	1
9	03-HAB-940	Fuse: 2.5 Amp	1		03-BC-938	Overload Relay: 23-32 Amp	1
10	03-HA-995	Transformer: 24V/115, 230V 50VA	1		03-5-1124	Overload Relay: 5.5-7.5 Amp (GE)	1
	03-HAB-911	Transformer: 24V/208, 230, 460V 50VA	1			(Use with 5H)	
11	08-6-250	Screw, Php HD, Slf Tpg 8-32 x 1/2	1		03-5-1125	Overload Relay: 10-16 Amp (GE)	1
12	03-HAB-906	Contactor: Rev, 10A, 24V, 50/60HZ	1			(Use with 5L, 7H & 20H)	
	03-BC-907	Contactor: Rev, 17.5A, 24V, 50/60HZ	1		03-5-1126	Overload Relay: 17.5-22 Amp (GE)	1
		(Use w/ 0L, 1H, 5L, 7H & 10H)				(Use with 7L)	
	03-C-909	Contactor: Rev, 32A, 24V, 50/60HZ	1		03-5-1124	Overload Relay: 25-32 Amp (GE)	1
		(Use w/ 1L, 7L & 10L)				(Use with 10L)	

SPECIFY HP, VOLTAGE, PHASE AND SERIAL NUMBER WHEN ORDERING CONTACTORS AND OVERLOAD RELAYS.

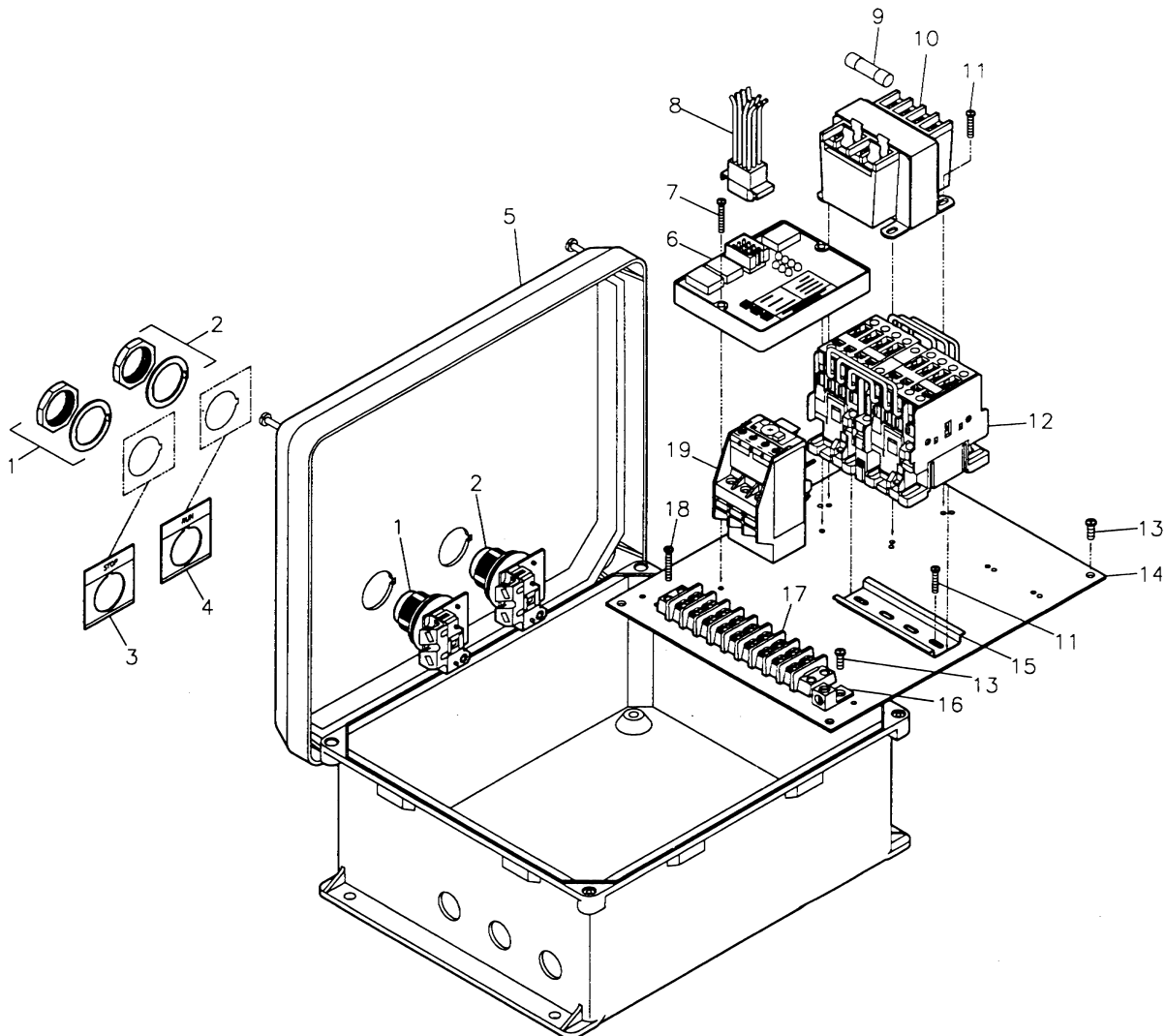

RAC2 & RAC2SS REPLACEMENT PARTS LIST

KEY NO.	PART NO.	NAME: DESCRIPTION	QTY. PER MACH.	KEY NO.	PART NO.	NAME: DESCRIPTION	QTY. PER MACH.
1	03-5-1036	Pushbutton Assy: Lighted, Red1 (RAC2)	1		03-C-909	Contactor: Rev, 32A, 24V, 50/60HZ.....1 (Use w/ 7L & 10L)	1
2	03-5-1037	Pushbutton Assy: Lighted, Amber1 (RAC2)	1		NOTE: Must Order Overload P/N 03-05-1124, 25, 26 & 27 with Contactors For Sizes 5L/H through 10L/H.		
3	03-5-1023	Legend Plate: "STOP"1	1	17	08-5-949	Screw, Php HD, 10-32 x 1/2.....4	4
4	03-5-1025	Legend Plate: "RUN"1	1	18	03-5-983	Base Plate: RAC1 & RAC21	1
5	03-5-1049	Handle: Disconnect Switch.....1 (w/Shaft) (RAC2)	1	19	03-5-1067	Track: Contactor Mounting1	1
6	03-5-1042	Enclosure: Non-Metallic, RAC1 & 21	1	20	03-5-1097	Grounding Lug.....1	1
	03-5-1072	Enclosure: SS, RAC21	1	21	03-5-1002	Terminal Strip: 9 Position.....1	1
7	03-5-1034	Control Module1	1		03-5-1001	Terminal Strip: 6 Position.....1	1
8	08-6-258	Screw: Php HD, Slf Tpg 8-32 x 12	2		03-5-1085	Terminal Strip: 13 Position.....1	1
9	03-5-999	Wiring Harness: RAC21	1	22	03-BC-935	Overload Relay: 12-18 Amp1	1
10	03-HAB-940	Fuse: 2.5 Amp1	1		03-B-936	Overload Relay: 5.5-8 Amp1	1
11	03-HA-995	Transformer: 24V/115, 230V 50VA1	1		03-C-937	Overload Relay: 17-25 Amp1	1
	03-HAB-911	Transformer: 24V/208, 230, 460V 50VA...1	1		03-BC-938	Overload Relay: 23-32 Amp1	1
12	08-6-250	Screw, Php HD, Slf Tpg 8-32 x 1/26	6		NOTE: Overload Relays Thru S/N 111995		
13	03-5-1120	Shaft: Disconnect Switch: RAC2.....1	1		03-5-1124	Overload Relay: 5.5-7.5 Amp (GE)1 (Use with 5H)	1
14	08-6-251	Screw, Php HD, Slf Tpg 8-32 x 3/44	4		03-5-1125	Overload Relay: 10-16 Amp (GE)1 (Use with 5L, 7H & 20H)	1
15	03-HAB-906	Contactor: Rev, 10A, 24V, 50/60HZ.....1 (Use w/ 0H, 2L, 2H & 5H)	1		03-5-1126	Overload Relay: 17.5-22 Amp (GE)1 (Use with 7L)	1
	03-BC-907	Contactor: Rev, 17.5A, 24V, 50/60HZ.....1 (Use w/ 0L, 1H, 5L, 7H & 10H)	1		03-5-1124	Overload Relay: 25-32 Amp (GE)1 (Use with 10L)	1
					NOTE: Overload Relays S/N 112095 Forward		

SPECIFY HP, VOLTAGE, PHASE AND SERIAL NUMBER WHEN ORDERING CONTACTORS AND OVERLOAD RELAYS.

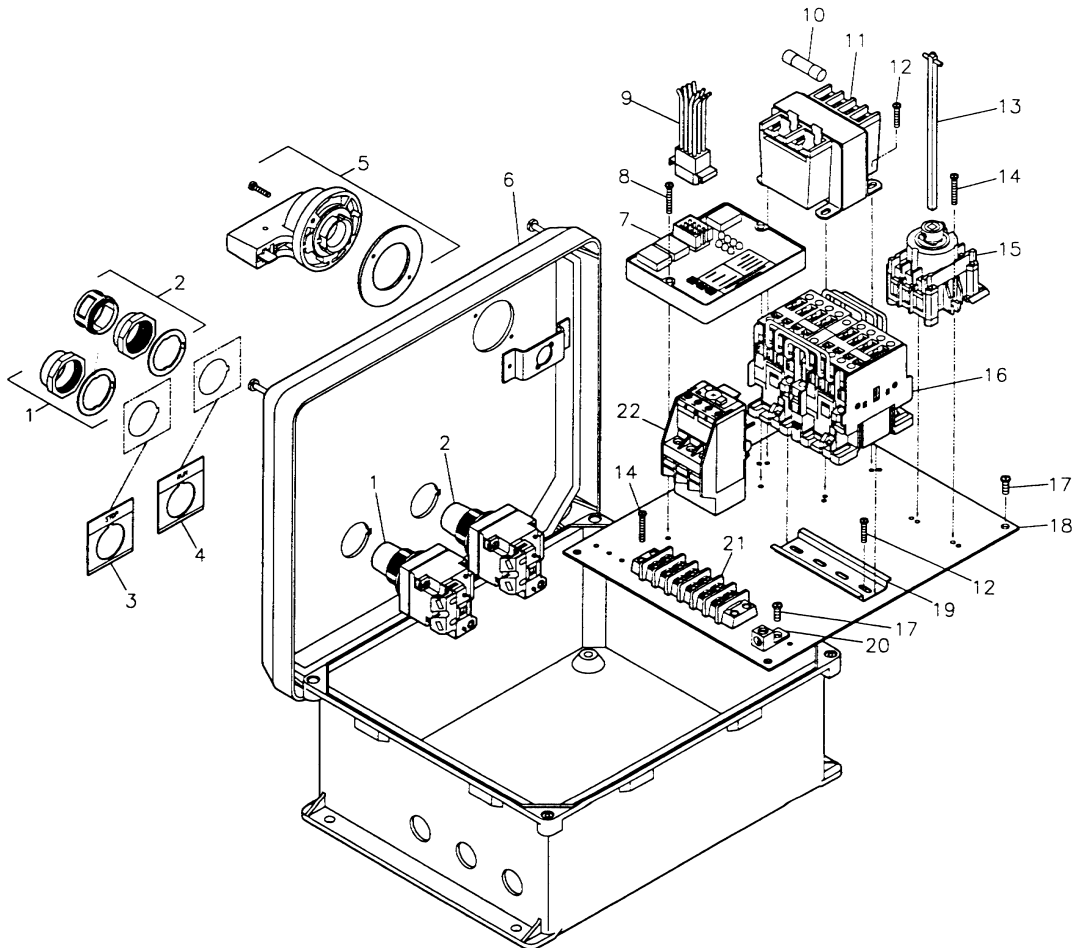

WARRANTY

THE INSINGER EXCLUSIVE ONE AND TEN YEAR WARRANTY

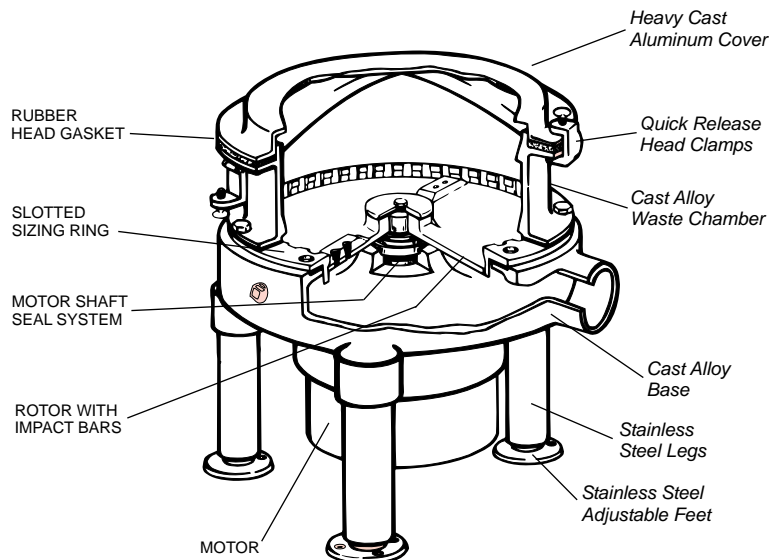

STANDARD ONE YEAR WARRANTY

All INSINGER disposer components, shown above in **BLOCK** print, are guaranteed against all defects for the initial **ONE YEAR** period of use, as stated in the Warranty.

INSINGER TEN YEAR WARRANTY

All INSINGER basic body components, shown above in *italicized* print, are guaranteed to remain serviceable for at least **TEN YEARS**, as stated in the Warranty.

All products (and parts) manufactured and sold by INSINGER DISPOSERS (the "Manufacturer") are warranted to be free from defects in material and workmanship for a period of one year following the date of its initial installation or eighteen months from the date of shipment from the factory or factory warehouse, whichever expires first. Notice of a claim under this Warranty must be received by the Manufacturer at its offices before the expiration of such period in order for Warranty coverage of **PARTS AND LABOR** to apply.

If notice of a claim is timely made, the Manufacturer will repair or replace the product or part which is defective either at the user's facility or at the Manufacturer's plant, as the Manufacturer shall decide. In addition, the Manufacturer warrants that the basic body components of every INSINGER Disposer will remain serviceable for a period of at least **TEN YEARS**. Should any of these basic body components require replacement during the first ten years of normal usage following installation the Manufacturer will furnish new duplicate parts to the original user at no charge. Manufacturer cannot warrant products returned to the factory not properly packaged, causing additional damage.

This Warranty shall not apply to the extent that products or parts have been used other than in conformance with operating and maintenance instructions, subjected to misuse or abuse or damage by accident, act of God, abnormal use or stress or any other matter unrelated to the Manufacturer, and beyond its reasonable control or otherwise altered or modified by third parties. In addition, this Warranty does not cover normal wear items, such as sizing rings, impact bars and rotors. **THIS WARRANTY IS EXCLUSIVE AND IS IN LIEU OF ALL OTHER WARRANTIES, EXPRESSED AND IMPLIED, INCLUDING THE IMPLIED WARRANTIES OF MERCHANTABILITY AND FITNESS FOR PURPOSE.** In no event shall the Manufacturer be liable for loss of use, revenue or profit or for indirect or consequential damages.

HOURS OF OPERATION

Insinger is available to assist you and your team day or night. Our regular business hours are Monday through Friday, 8:00 AM - 5:00 PM (EST). After-hours inquiries may take longer to respond.

CONTACTS

SALES

Kim Croft
Director of Business Development
E: kcroft@insingermachine.com
D: (215) 624-4800 x124
C: (630) 400-3656

David Baysinger
Regional Sales Manager
E: dbaysinger@insingermachine.com
D: (215) 624-4800 x111

ORDERS & QUOTES

Edward Gerhard
Account Manager
E: egerhard@insingermachine.com
D: (215) 624-4800 x116

Deniece Heard
Customer Service
E: dheard@insingermachine.com
D: (215) 624-4800 x120

MARKETING

Matthew Weisbecker
Strategic Marketing Manager
E: mweisbecker@insingermachine.com
D: (215) 624-4800 x131

SERVICE & SUPPORT

Jason Striker
Parts & Service Manager
E: jason@insingermachine.com
D: (215) 624-4800 x139

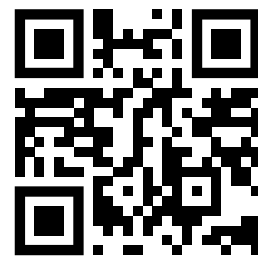

Digital Contact Cards

