

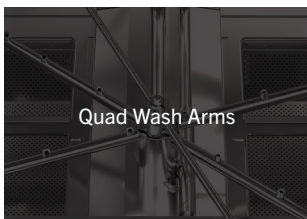

# CX20VG

Ventless Door Type Dishwasher

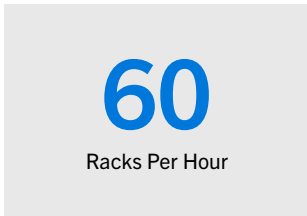

## SPECIFIER STATEMENT

Specified unit will be a CX20VG ventless high temperature door type dishwasher with VaporGuard. Features include built-in HeatCore booster, StatusGlow LED indicator bar, Ergo-grip door handle, foot-operated drain pedal, ScrapShield oversized scrap screens, quad-arm wash system, and RackAware rack detection. Includes a 1-year parts and labor warranty.

## STANDARD FEATURES

- Washes 60 racks (20" x 20") per hour
- Built-in HeatCore booster
- ENERGY STAR® 3.0 certified
- Ergo-grip door handle
- Foot-operated drain pedal
- InfoPanel multi-line display
- Quad-arm wash system
- RackAware rack detection system
- ScrapShield oversized scrap screens
- StatusGlow LED indicator bar
- VaporGuard™ ventless system with cold water inlet connection
- Adjustable leveling feet
- Anti-vandal stainless steel buttons
- De-lime program for easy cleaning
- Detergent connection provision
- Dish rack guides nest & lock
- Door safety switch
- Easy-access swing out corner control panel
- Energy conservation drain overflow
- Front mounted wash tank
- Gas door springs
- Hinged dish rack support
- Low water protection
- Multiple cycles: wash, extended, heavy, and delime
- Non-proprietary components
- Single point or dual point electrical option
- Stainless steel frame, legs and feet
- Waterproof IP67 control board

## OPTIONS & ACCESSORIES

- 20" x 20" dish racks (peg or flat)
- Drain cooldown system
- External steam booster
- False panel kit for corner installation
- Flanged feet
- Security package

# TECHNICAL INFORMATION

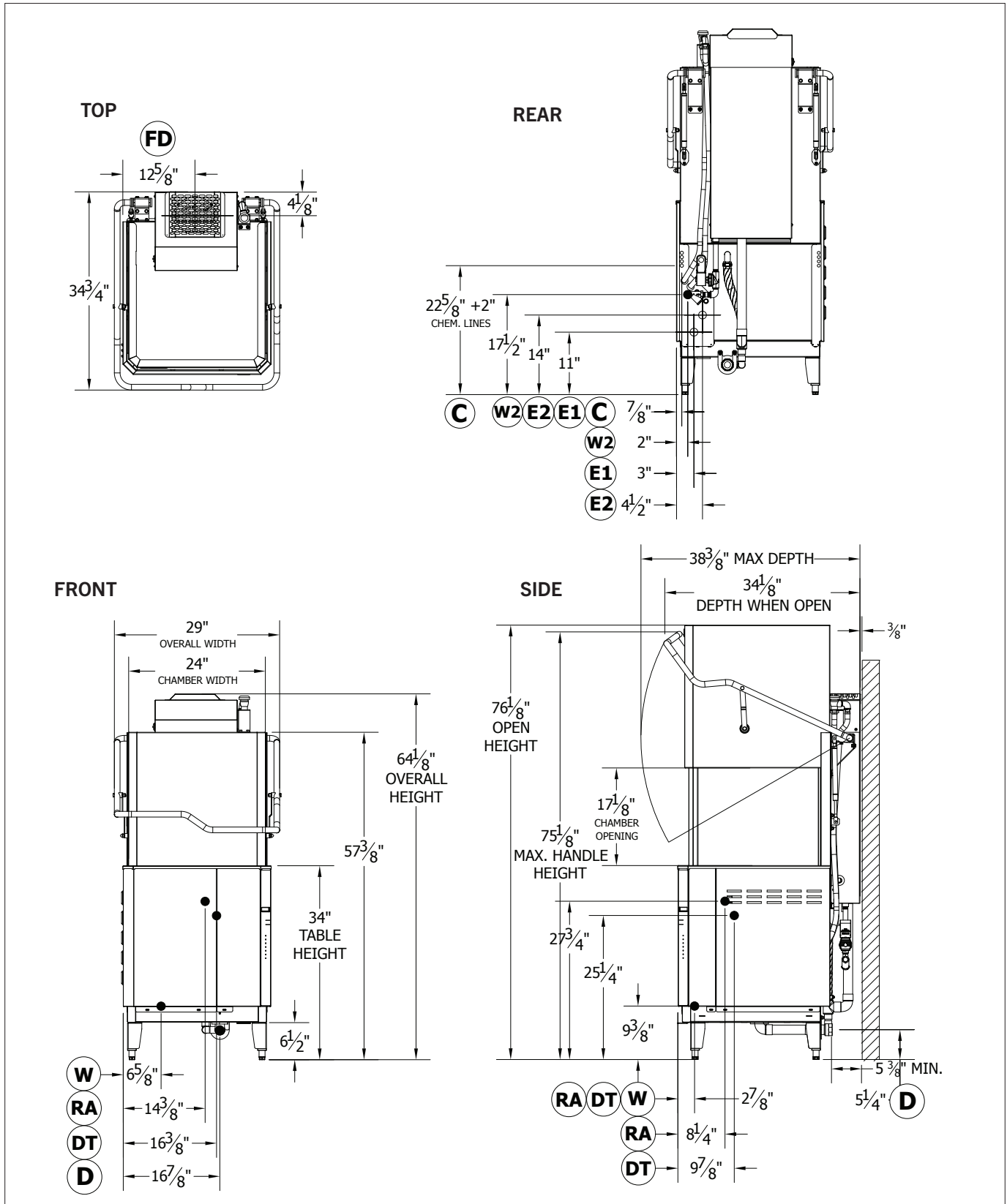

## SPECIFICATIONS

<b>Capacity</b>	Racks Per Hour	60
	Dishes Per Hour	1,500
	Meals Per Hour	2,400
<b>Cycle Times</b>	Standard (Cycle 1)	60 sec
	Extended (Cycle 2)	120 sec
	Heavy (Cycle 3)	210 sec
<b>Heat</b>	Tank Heat	9.0 kW
	Booster Heat	9.0 kW
	Booster Capacity	2.3 gal
	Latent Heat	4,046 btu/hr
	Sensible Heat	8,224 btu/hr
	Total Heat	12,720 btu/hr
<b>Water</b>	Water Inlet Temperature	110°F
	Water Consumption (20 PSI)	.65 gal/rack
	Wash Tank Capacity	17.5 gal
	Peak Rate Drain Flow	35 gal/min
	VG Cold Water Consumption (20 PSI)	4.0 gal/hr
<b>Steam</b>	Steam Tank Consumption	11 lbs/hour
	Steam Consumption (40°F rise)	22 lbs/hour
	Steam Consumption (70°F rise)	43 lbs/hour
	Peak Drain Flow	35 gal/min
<b>Other</b>	Wash Motor Size	1.5 hp
	Built-In Booster	Standard
	Shipping Weight	500 lbs

## ELECTRICAL

	Service Options	Total Load	
<b>Electric Tank Heat (Single Point)</b>	208/60/1	96.1 A	
	208/60/3	54.0 A	
	240/60/1	84.3 A	
	240/60/3	47.8 A	
	480/60/3	23.8 A	
	Service Options	E1	E2
<b>Electric Tank Heat (Dual Point)</b>	208/60/1	52.8 A	43.3 A
	208/60/3	30.0 A	25.0 A
	240/60/1	46.8 A	37.5 A
	240/60/3	26.1 A	21.7 A
	480/60/3	13.0 A	10.8 A

## LEGEND

Type	Label	Description	Note
<b>Water</b>	<b>D</b>	Drain Connection	1-1/2 FPT
	<b>W</b>	Hot Water Inlet (110 F Min)	1/2 FPT
	<b>W2</b>	Cold Water Inlet (80 F Max)	1/2 FPT
<b>Electrical</b>	<b>E1</b>	Main Electrical (Single & Dual-Point)	1-3/8 HOLE
	<b>E2</b>	Booster Electrical (Dual Point Only)	1-3/8 HOLE
	<b>CP</b>	Conductivity Probe Location	7/8 HOLE
<b>Chemical</b>	<b>DT</b>	Detergent Insertion Points	7/8 HOLE
	<b>PS</b>	Pressure Switch Connection	1/4 FPT
	<b>RA</b>	Rinse Aid Connection	1/4 FPT
	<b>C</b>	Chemical Line & Signal Access	1/2 HOLES (4)

Contact Insinger Sales at 800-344-4802 for an installation drawing specific to your application.  
 Note: Due to product improvement we reserve the right to change information and specifications without notice.