



Project _____
 Item _____ Quantity _____
 Approved by _____ Date _____
 AIA/SIS # _____



STANDARD FEATURES

- 10 HP motor paired with extra large 15" rotor and cutting disc
- Designed to handle huge quantities and the toughest food materials
- Ideal for the disposal of big steer ribs, leg or knuckle bones (even raw), lobster shells, poultry carcasses, fish heads, pineapples and regular or wax-coated paper waste
- Rugged cast metal construction

SERIES G ROTOR

15" Commercial Food Waste Disposer



OPTIONS & ACCESSORIES

- 5 HP motor
- 7.5 HP motor
- Cones 12", 15", 18"
- Offset-body for maximum space utilization, also available for both cone & sink attachments
- Stainless steel cone or sink attachment (includes vinyl silver trap ring, solenoid valve, flow control valve, vacuum breaker)

SPECIFIER STATEMENT

Specified unit will be an Insinger Series G heavy-duty food waste disposer. Features include rugged construction, an extra-large 15" rotor, and a powerful 10 HP motor designed to handle the toughest material in central food waste areas. Includes a 1-year parts and labor warranty.

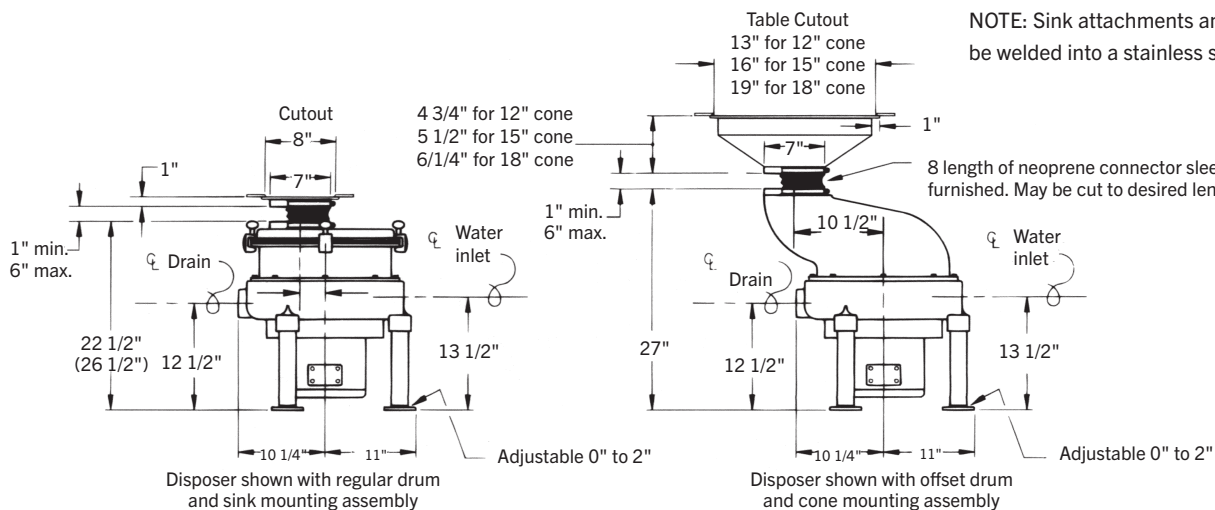

NOTE: All dimensions shown at 0" foot height adjustment.

ELECTRICAL

THREE PHASE

Motor Size	Voltage (60 Hz)	Load	Voltage (50 Hz)	Load
5 HP	208 V	14.5 A	208 V	19.4 A
	230 V	14 A	N/A	
	460 V	7.5 A	415 V	9.7 A
7.5 HP	208 V	23 A	N/A	
	230 V	22 A		
	460 V	11 A		
10 HP	208 V	30 A		
	230 V	28 A		
	460 V	14 A		