



Project _____
 Item _____ Quantity _____
 Approved by _____ Date _____
 AIA/SIS # _____



SERIES I ROTOR

6" Commercial Food Waste Disposer



STANDARD FEATURES

- 1.25 HP motor
- Durable 6" rotor
- Mounts directly to sink flange
- Designed primarily for the smaller foodservice operations (i.e. salad prep station)
- Ideal for small cafe, snack bar, or elementary school where food waste volume is light
- Note: does not include floor support

OPTIONS & ACCESSORIES

- 0.5 HP motor (light duty)
- 0.75 HP motor (light duty)
- Cones 12", 15", 18"
- Stainless steel cone or sink attachment (includes vinyl silver trap ring, solenoid valve, flow control valve, vacuum breaker)
- Support Leg

SPECIFIER STATEMENT

Specified unit will be an Insinger Series I food waste disposer. Designed for small to large restaurant kitchens, it features durable construction, a 6" rotor, and requires no floor support. Ideal for light food waste volumes in smaller operations. Includes a 1-year parts and labor warranty.

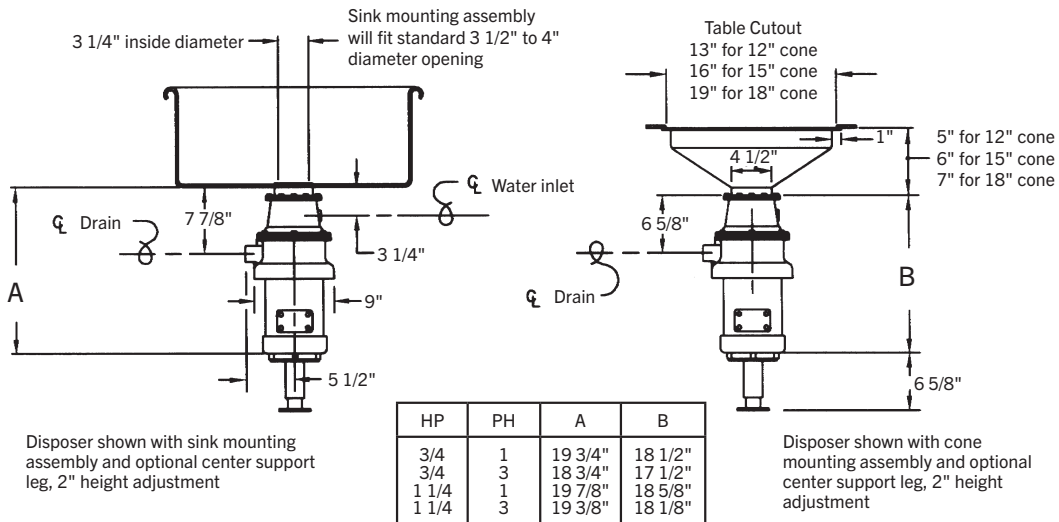

ELECTRICAL

Motor Size	THREE PHASE		SINGLE PHASE		THREE PHASE		SINGLE PHASE	
	Voltage (60 Hz)	Load	Voltage (50 Hz)	Load	Voltage (60 Hz)	Load	Voltage (50 Hz)	Load
0.5 HP	208 V	2.5 A	208 V	2.6 A	115 V	4.6 A	110 V	6.8 A
	230 V	2.4 A	N/A		230 V	2.3 A	220 V	3.4 A
	460 V	1.2 A	415 V	1.3 A	N/A		N/A	
0.75 HP	208 V	2.6 A	208 V	2.6 A	115 V	6.3 A	110 V	8.2 A
	230 V	2.4 A	N/A		230 V	3.15 A	220 V	4.1 A
	460 V	1.2 A	415 V	1.3 A	N/A		N/A	
1.25 HP	208 V	3.7 A	208 V	4 A	115 V	11.1 A	110 V	12.8 A
	230 V	3.6 A	N/A		230 V	5.05 A	220 V	6.4 A
	460 V	1.8 A	415 V	2 A	N/A		N/A	