



Project _____

Item _____ Quantity _____

Approved by _____ Date _____

AIA/SIS # _____



Front-Load

Corner

Pass-Through

SW12

Pot & Pan Washer



12

Pans Per Rack

Military-Grade Build Quality

Hold-Down Rack System



Made in the USA

STANDARD FEATURES

- **Designed for heavy duty applications**
- **Digital temperature controller for wash and rinse**
- **Fully automatic operation**
- **Hold-down rack system**
- Automatic fill
- Detergent connection provisions
- Emergency cycle stop button
- Lift-up door design
- Low water cut-off
- Pan washer clean-up hose and spray gun
- Pressure regulator to maintain 20 psi rinse flow
- Rinse pressure gauge
- Single point electrical connection
- Three position cycle selector (complete times):
Light (260 seconds), Medium (380 seconds),
Heavy (500 seconds)
- Wash pump pressure gauge

OPTIONS & ACCESSORIES

- Corner Configuration
- Electric Booster
- Pass-Through Configuration
- Recommended option: power vent fan
- Security package
- Steam booster
- Totally enclosed motor
- Wash tank heat system: Electric
- Wash tank heat system: Gas
- Wash tank heat system: Steam Coil
- Wash tank heat system: Steam Injection

SPECIFIER STATEMENT

Specified unit will be an Insinger SW12 pot and pan washer. Features include fully automatic operation, hold-down rack system, automatic fill, digital temperature controller for wash and rinse, and a three-position wash selector with light, medium, and heavy cycles. Includes a 1-year parts and labor warranty.

TECHNICAL INFORMATION

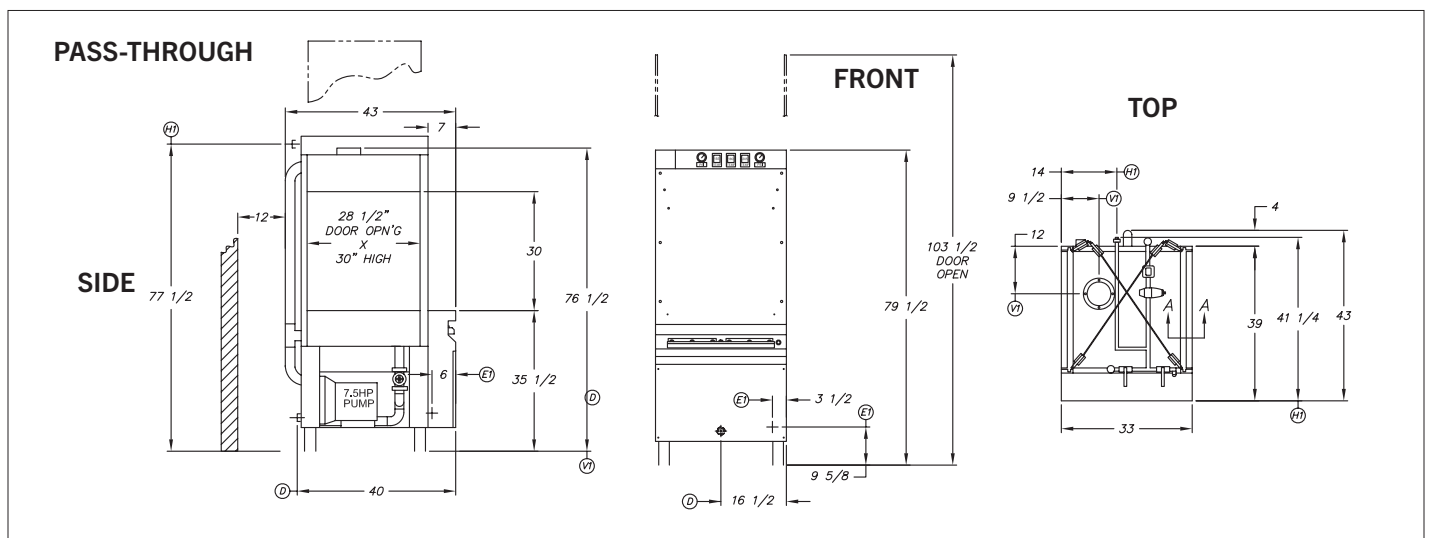
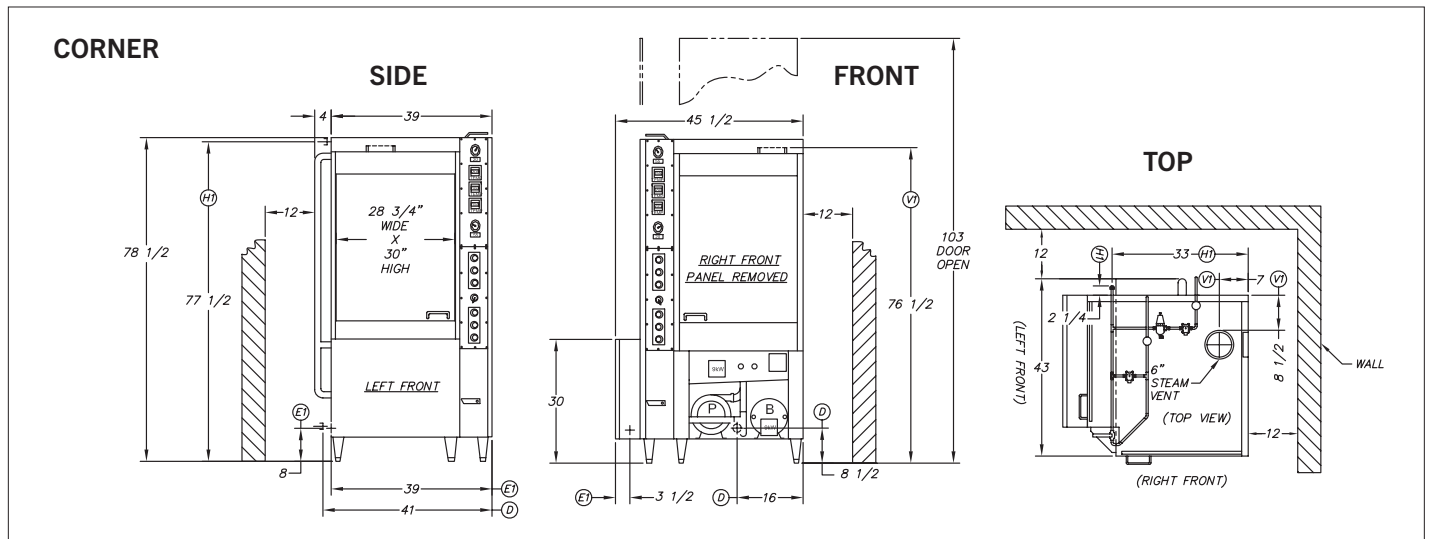
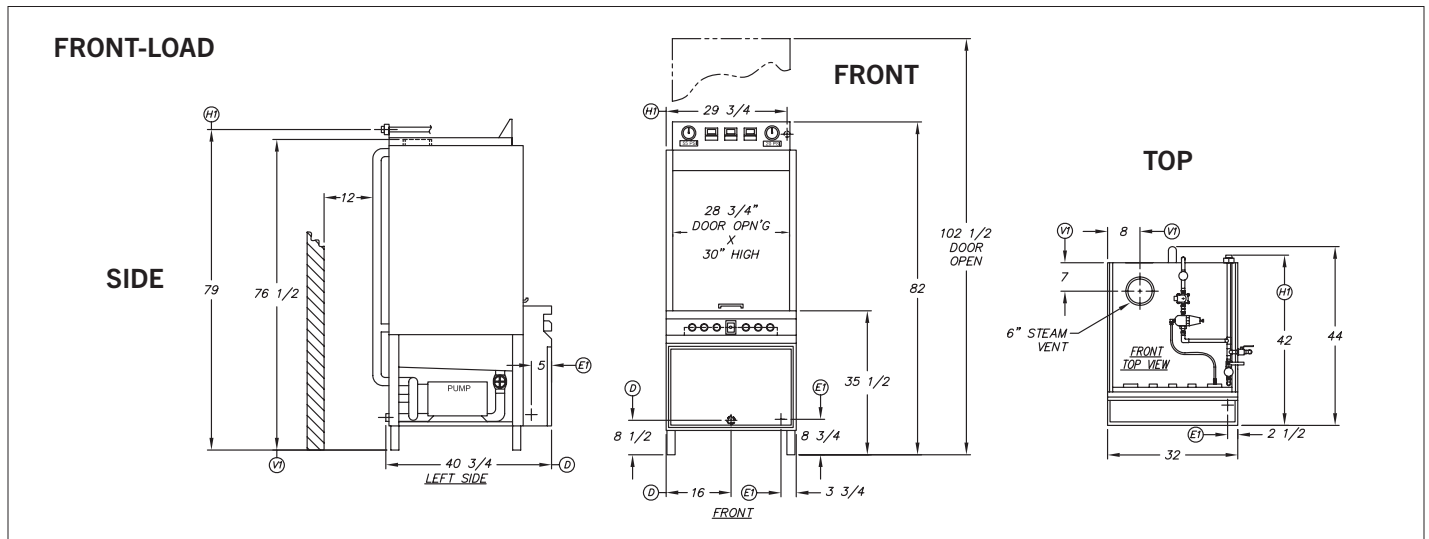

SPECIFICATIONS

Capacity	Pans Per Rack	12
	Sheet Pans Per Hour	156
Heating & Venting	Wash Tank Heat	9 kW
	Rinse Booster Heat	9 kW
	Exhaust Hood Requirement	6" Steam Exhaust Vent
	Water Inlet Temperature	110°F
Water	Water Consumption (20 PSI)	49.5 gal/hr
	Final Rinse Peak Flow (20 PSI)	4.5 gal/cycle
	Wash Tank Capacity	30 gal
	Peak Drain Flow	5 gal/min
	Steam Tank Consumption (Injected, 10-15 PSI)	18 lbs/hr
Steam	Steam Tank Consumption (Coil, 10-15 PSI)	36 lbs/hr
	BTUH Capacity	36,000
Gas	Natural Gas Consumption (7" W.C. Minute)	35 CFH
	Propane Consumption (11" W.C. Minute)	14 CFH
	Wash Motor	7.5 HP
Other	Shipping Weight	1,175 lbs

ELECTRICAL

	Service Options	SW12 (Electric)	SW12 (Gas)	SW12 (Steam)
Electrical Options	208/60/3	70.0 A	45.0 A	20.0 A
	230/60/3	64.4 A	41.8 A	19.2 A
	460/60/3	33.2 A	21.9 A	10.6 A

Contact Insinger Sales at 800-344-4802 for an installation drawing specific to your application.
 Note: Due to product improvement we reserve the right to change information and specifications without notice.