



Project \_\_\_\_\_

Item \_\_\_\_\_ Quantity \_\_\_\_\_

Approved by \_\_\_\_\_ Date \_\_\_\_\_

AIA/SIS # \_\_\_\_\_



# TRAC-TS

Automatic Tray Stacking System

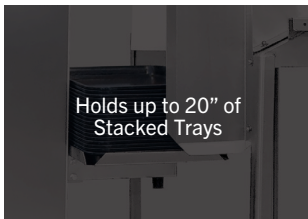
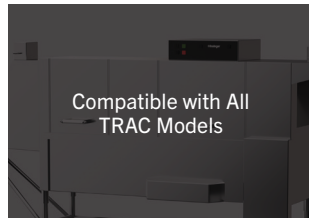
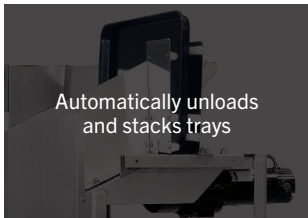

## STANDARD FEATURES

- Adjustable for tray lengths of 14" to 26"
- Automatically unloads and stacks trays onto tray handling cart
- Compatible with all TRAC models
- Faster and more sanitary than manual tray handling
- Holds up to 20" of stacked trays (approximately 60 trays)
- Works with flat or compartment trays (metal, plastic, nylon, and fiberglass)
- Designed for left or right hand conveyor travel, as specified
- Factory pre-configured for tray washers purchased with TD-321 tray dryers
- Full stainless steel construction
- Labor-saving: requires only one operator
- Not compatible with disposable foam or fiber trays
- Not sold separately — must be purchased with TRAC series traywasher and TD-321 tray dryer
- Optional full-cart switch automatically shuts down system to prevent overflow
- Prevents cross contamination by eliminating manual handling of clean trays
- Reduces bacteria growth
- Tray unloading rate synchronized with dryer processing speed
- Trays and carts are easily removed when full
- Trays are processed in same-size/style batches and nest when stacked

## SPECIFIER STATEMENT

Specified unit will be a TRAC-TS tray stacker for use with TRAC series tray washers and TD-321 tray dryers. Features include automatic unloading and stacking of trays, compatibility with trays from 14" to 26", full stainless steel construction, labor-saving one-operator design, and synchronized unloading with dryer speed. Includes a one (1) year parts & labor warranty.

## OPTIONS & ACCESSORIES

- Additional carts for speed handling
- Full-cart switch to automatically shut down machine
- In-place and full cart interlocks

# TECHNICAL INFORMATION

## LEFT TO RIGHT

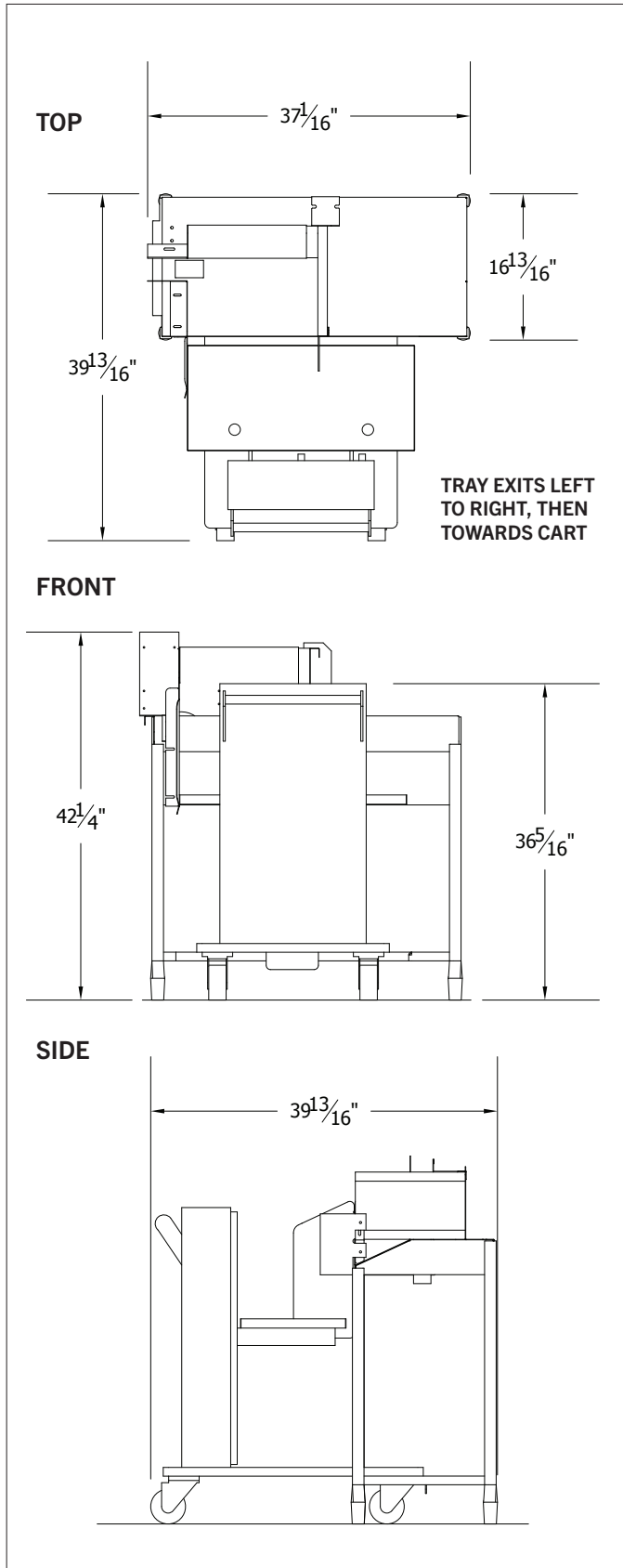

## RIGHT TO LEFT

