



Project \_\_\_\_\_

Item \_\_\_\_\_ Quantity \_\_\_\_\_

Approved by \_\_\_\_\_ Date \_\_\_\_\_

AIA/SIS # \_\_\_\_\_

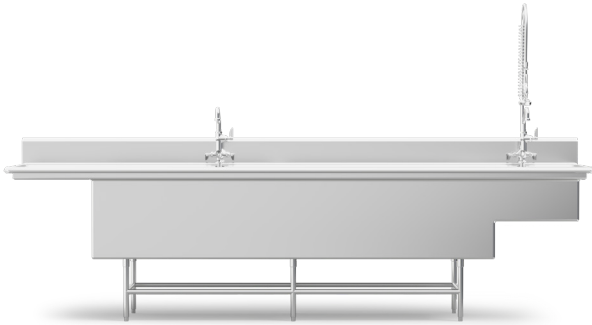

# AQUASCRUBBER 140

Automatic Sink System



## STANDARD FEATURES

- 14-Gauge stainless steel construction
- 2 HP TEFC heavy-duty pump
- 2.5 kW heater with low-water protection
- Angled corners to eliminate jams
- Quad-jet wash system (six high-velocity jets)
- 11" backsplash
- Dual temp settings: 110°F (low) / 130°F (high)
- Fast-flow mixing faucets
- Front-mounted controls (on/off for pump and heater)
- High-capacity basket-style waste drain
- Left or right hand configuration
- NEMA 4X control panel enclosure
- Seamless, easy-clean front skirt
- Single-point electrical for motor, controls, heater
- Stainless steel utensil basket
- T304 series stainless steel construction
- Welded legs with stainless steel feet
- Model: Marathon 140

# 2 HP

TEFC Pump



Highly Customizable



Two Standard Configurations Available



Made in the USA

## OPTIONS & ACCESSORIES

- 1 to 8 hour wash pump timer
- Disposal and cone (in soiled drain board, 48" minimum length)
- End splash
- Hot water sanitizing booster heater
- Overshelf with mounting brackets (12" increments, 60" and up)
- Pre-rinse and gooseneck faucets
- Scrapper drain board with pre-rinse faucet
- Scrap trough in drain board
- Shelves (cantilevered or wall mounted)
- Sink overflows
- Undershelf on clean end drain board

## SPECIFIER STATEMENT

Specified unit will be an Insinger AquaScrubber 140 (Marathon 140) automatic sink system. Features include a 2 HP TEFC pump, Quad-jet wash system with six high-velocity jets, 2.5 kW heater with low-water protection, dual temperature settings, fast-flow mixing faucets, and a high-capacity basket-style waste drain. Includes a one (1) year parts and labor warranty.

Due to the highly configurable design of this product, **please contact the factory** for detailed specifications and technical drawings. Call 800-344-4802 or email [sales@insingermachine.com](mailto:sales@insingermachine.com).

# TECHNICAL INFORMATION

## MARATHON 140 - LEFT TO RIGHT CONFIGURATION

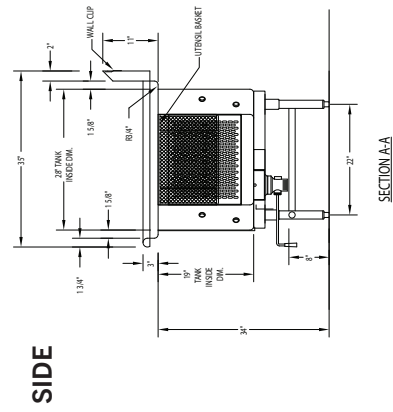
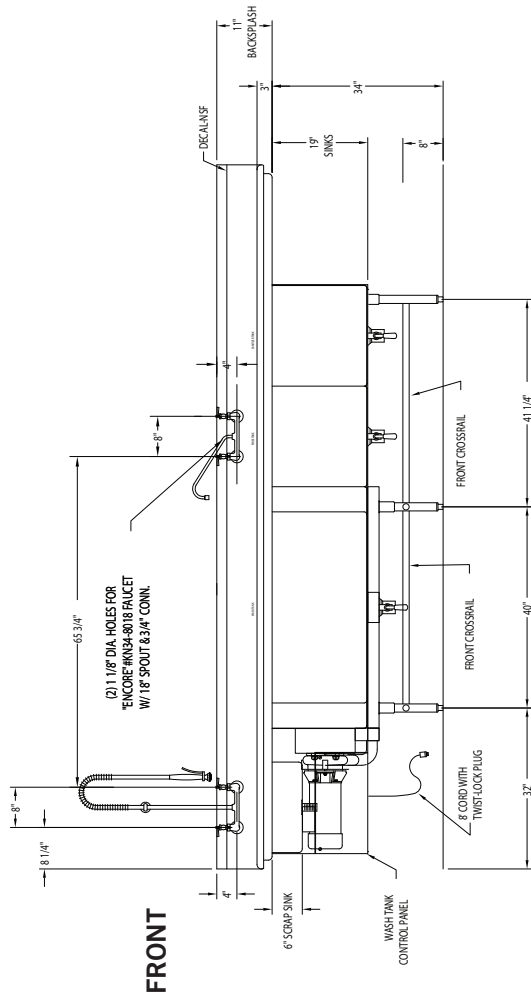
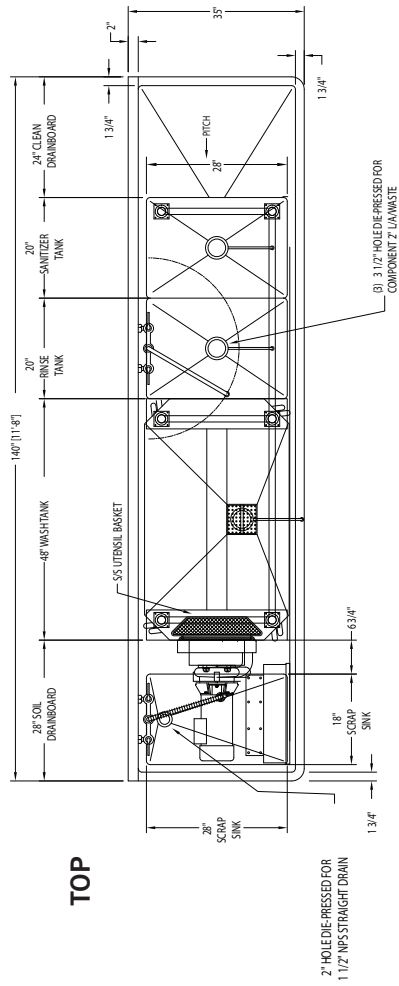

# TECHNICAL INFORMATION

## MARATHON 140 - RIGHT TO LEFT CONFIGURATION

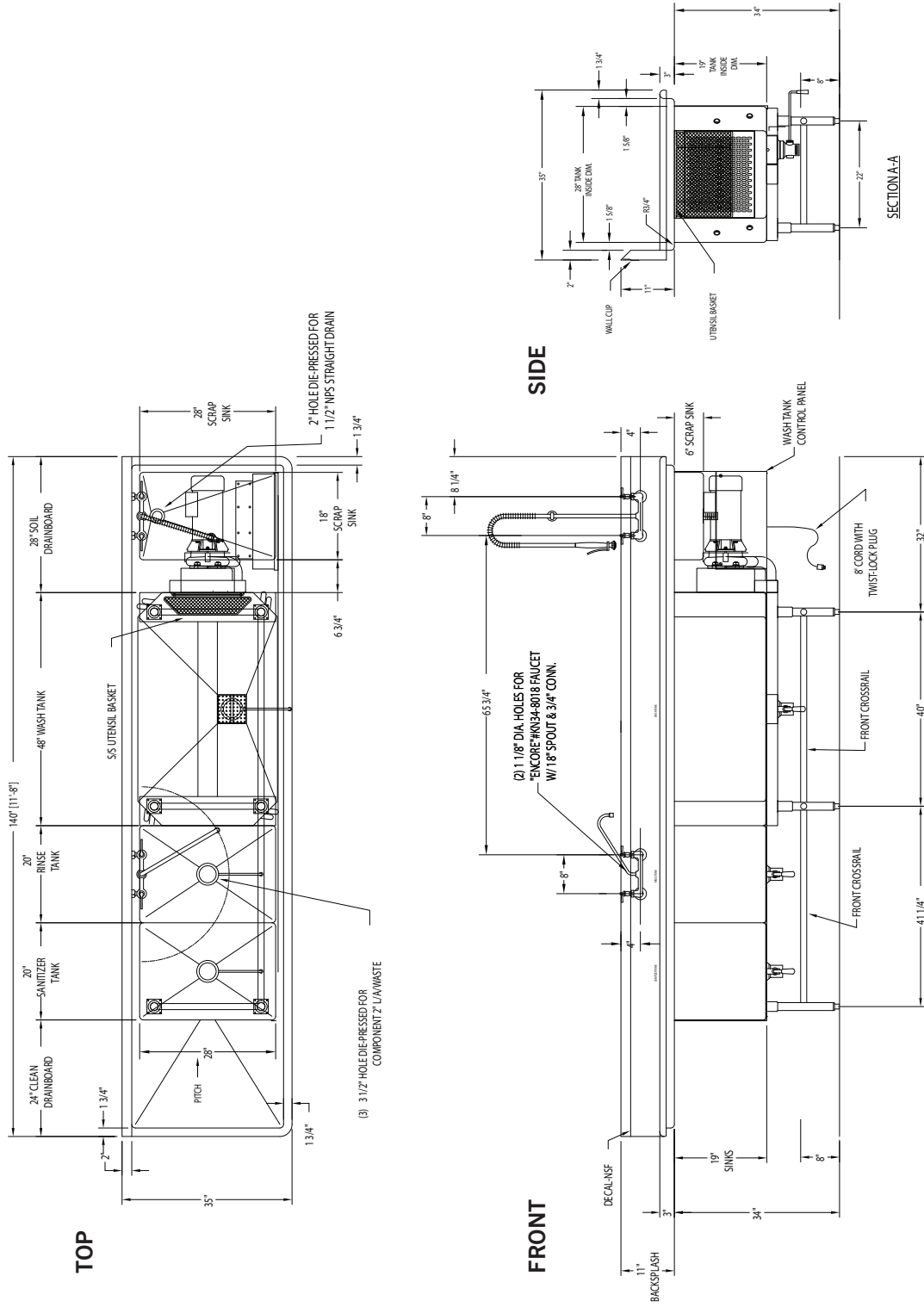

## SPECIFICATIONS

Motor Size	2 HP
Heater Size	2.5 kW
Shipping Weight (Marathon)	140-650 lbs.

## ELECTRICAL

Service Options	Heater	Pump & Controls	Total
208/60/1	12 A	9.6 A	21.6 A
208/60/3	6.9 A	5.9 A	12.8 A
240/60/1	10.9 A	8.9 A	19.8 A
240/60/3	6.3 A	5.6 A	11.9 A
480/60/3	3.1 A	2.8 A	5.9 A

Contact Insinger Sales at 800-344-4802 for an installation drawing specific to your application.  
 Note: Due to product improvement we reserve the right to change information and specifications without notice.