



Vessel _____

Item _____ Quantity _____

Approved by _____ Date _____

NSN # _____



45SA

Scullery Undercounter Dishwasher



45
Racks Per Hour

Military-Grade Build Quality

Shipboard-Ready Design

Made in the USA

STANDARD FEATURES

- Washes 45 racks per hour
- Bulk-head mounted NEMA 12 control panel
- Complies with ASTM specifications
- Designed for ward room operation
- Exact footprint replacement for USN-10
- 16-Gauge T304 stainless steel
- Automatic tank fill
- Capillary thermometers for wash and rinse
- Detergent and rinse additive connection provisions
- Door safety switch
- Low water protection
- Manual tank fill
- One (1) year parts & labor warranty
- Plastic 16" x 16" dish racks
- Pressure reduction valve and line strainer
- Simplified scrap screen design
- Standard frame TEFC motor
- Stainless steel frame
- Stainless steel level gauges
- Wash Tank (Electric) - 1.5 kW paired with 9 kW or 18 kW electric booster with low temp cut-off
- Wash Tank (Steam) - 1 stainless coil paired with steam booster with low temp cut-off

MODELS

- 45SA5-F1 (Steam coil tank heat)
- 45SA5-F2 (Electric tank heat - 9kW)
- 45SA5-F2NM (Non-magnetic pump and booster)
- 45SA5-F2D (Extra large booster - 18kW)
- 45SA7-F2 (Submarine configuration)

See next page for NSN information.

SPECIFIER STATEMENT

Specified unit will be a 45SA scullery undercounter dishwasher. Features include automatic tank fill, bulkhead-mounted NEMA 12 control panel, capillary thermometers for wash and rinse, low water protection, and detergent and rinse additive connection provisions.

TECHNICAL INFORMATION

FRONT

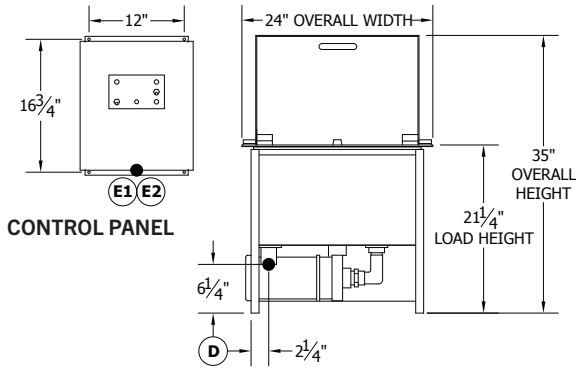

SIDE

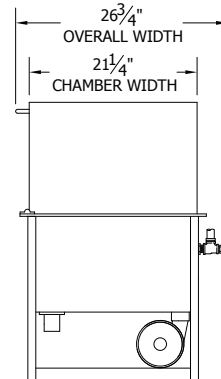

STEAM CONFIGURATION

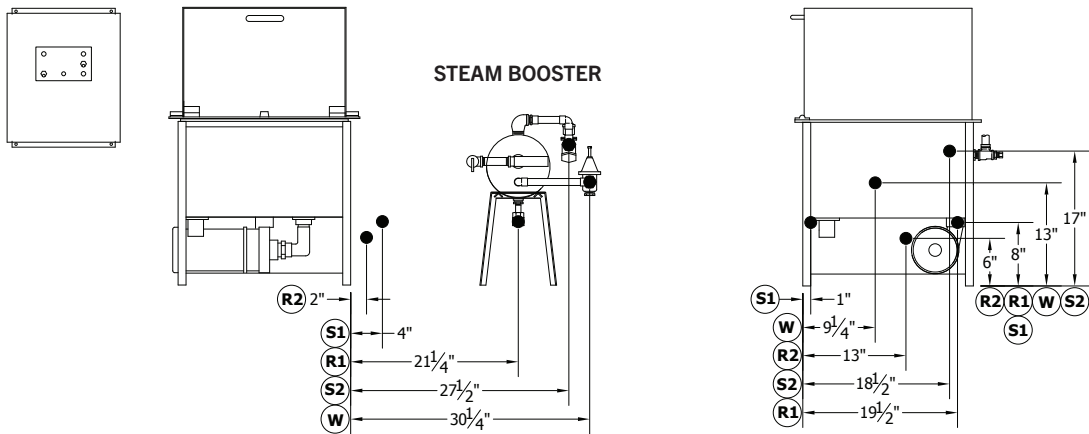

ELECTRIC CONFIGURATION

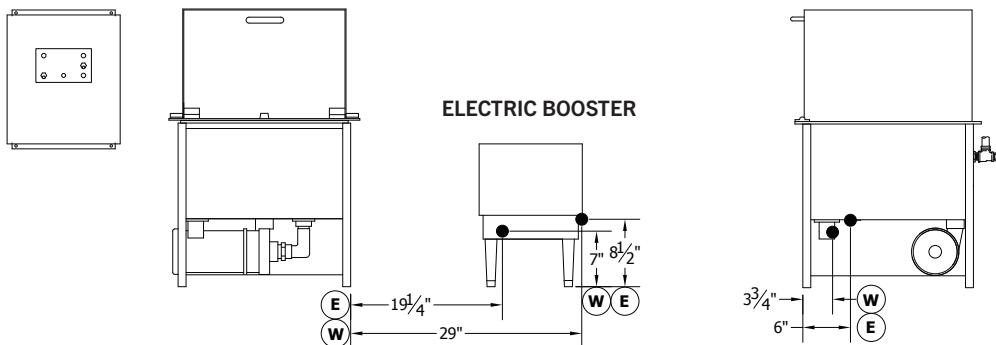

SPECIFICATIONS

Capacity	Racks Per Hour	45
Water	Wash Tank Capacity	9.0 gal
	Peak Drain Flow	9 gal/min
Steam	Steam Tank Consumption (16 PSI)	19 lbs/hr
Other	Wash Motor HP	0.5
	Shipping Weight	381 lbs

LEGEND

Type	Label	Description	Note
Water	W	HOT WATER CONNECTION	3/4 FIPS
	D	DRAIN CONNECTION	1.25 FIPS
Electrical	E1	ELECTRICAL CONNECTION - PUMP MOTOR	1/2 HP
	E2	ELECTRICAL CONNECTION - WASH HEATER	1.5 kW
	E3	ELECTRICAL CONNECTION - BOOSTER	9 kW - 18 kW
Steam	S1	STEAM TO TANK	1/2 FIPS
	S2	STEAM TO BOOSTER	3/4 FIPS
Other	R1	CONDENSATE RETURN - BOOSTER	3/8 FIPS
	R2	CONDENSATE RETURN - TANK	3/8 FIPS

NSN IDENTIFICATION

NSN	Model	Feature	Heating System & Booster	Electrical
7320-01-102-9456	45SA5-F1	Steam Coil Tank Heat	Steam I-2 Booster	440V / 60HZ / 3PH
7320-01-327-1526	45SA5-F2	Electric Tank Heat	Electric 9 kW Booster	
7320-01-409-1604	45SA5-F2NM	Non-Magnetic Build	Steam MC11 Booster	
7320-01-417-6566	45SA5-F2D	Extra Large Booster	Electric 18.1 kW Booster	
7320-01-414-3581	45SA7-F2	Submarine Build	Electric 13.5 kW Built-In Booster	

ELECTRICAL

	Model	Load	Item
Electrical Service (440/3/60)	45SA5-F1 (Steam)	1.4 A	Dishwasher and Booster
	45SA5-F2 (Electric)	3.1 A	Dishwasher
		9.9 A	9 kW Booster
	45SA5-F2D (Electric)	3.1 A	Dishwasher
		19.8 A	18 kW Booster
	45SA5-F2NM (Steam)	3.1 A	Dishwasher and Booster
	45SA7-F2 (Electric)	3.1 A	Dishwasher
16.3 A		13.5 kW Booster	