



Project _____

Item _____ Quantity _____

Approved by _____ Date _____

AIA/SIS # _____



SPEEDER 86

Double Tank Rack Conveyor Dishwasher with Pre-Wash



STANDARD FEATURES

- Washes 277 racks (20" x 20") per hour
- Alternative to flight type solution
- ColorCorrect dish curtains
- CrossFire™ wash system
- Easily-cleaned crowned hood top
- Elevated top-mounted NEMA 12 control panel
- Automatic tank fill
- Capillary thermometers for wash and rinse
- Detergent connection provision
- Door safety switch
- In-line thermometer for final rinse
- Left or right hand configuration
- Low water protection
- Override switch for de-liming
- Standard frame drip proof motors
- Timing belt conveyor drive
- Vacuum breaker on all incoming water lines
- Ventilation fan connection provision

277

Racks Per Hour

Military-Grade Build Quality

CrossFire™ Wash System



Made in the USA

OPTIONS & ACCESSORIES

- 20" x 20" dish racks (peg, flat, cup, or sheet pan)
- Door activated drain closers
- Drain water cooldown
- Electric booster
- End cowls with vent and damper controls
- Extra high hood
- Insulated hood and door
- Left or right hand feed
- Power Loader (Speeder/Super)
- Power Unloader
- Rack limit switch
- Security package
- Single point electrical connection (Booster requires a separate connection)
- Stainless steel splash guards
- Stainless steel steam coil tank heat
- Steam booster
- Steam pressure regulating valve
- Totally enclosed motors

SPECIFIER STATEMENT

Specified unit will be a Speeder 86 double tank rack conveyor dishwasher with recirculating pre-wash, wash, and rinse systems and fresh water final rinse. Features include ColorCorrect curtains, CrossFire wash system, elevated top-mounted NEMA 12 control panel, automatic tank fill, and capillary thermometers for wash and rinse. Includes a 1-year parts and labor warranty.

TECHNICAL INFORMATION (ELECTRIC)

LEFT TO RIGHT

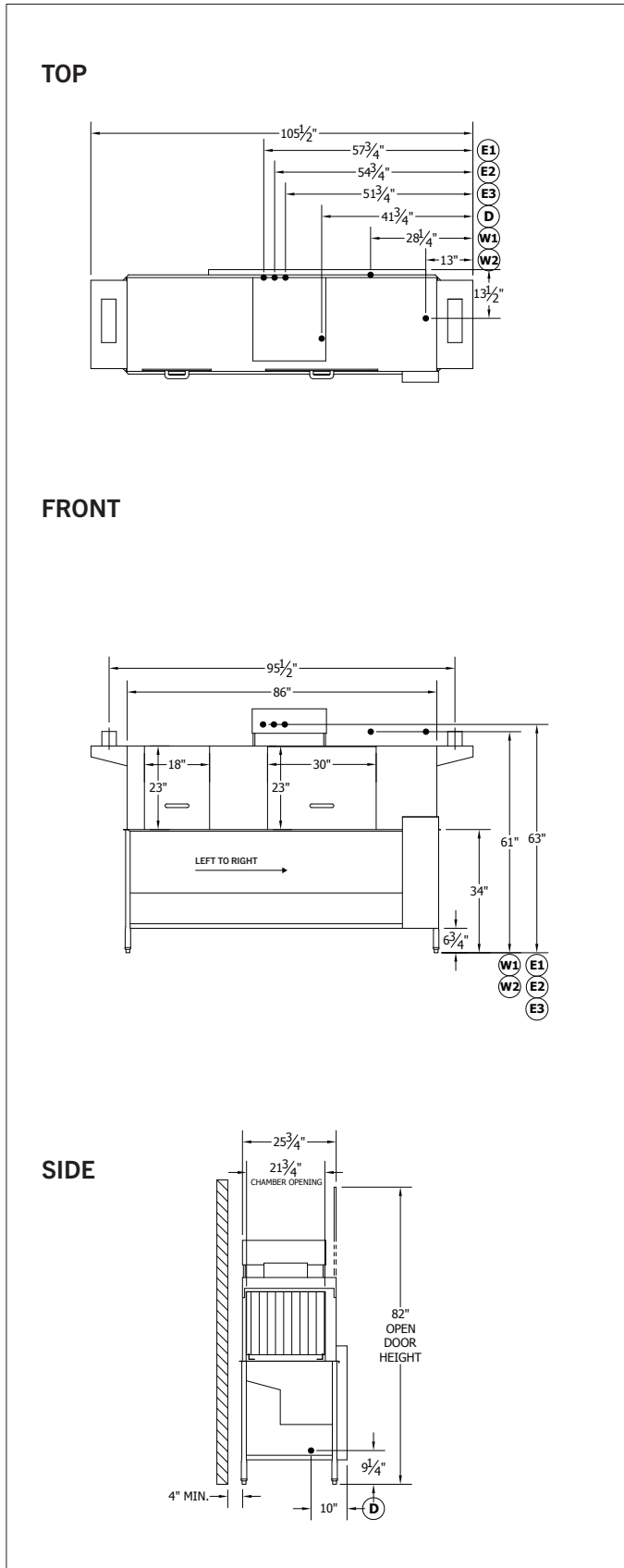

RIGHT TO LEFT

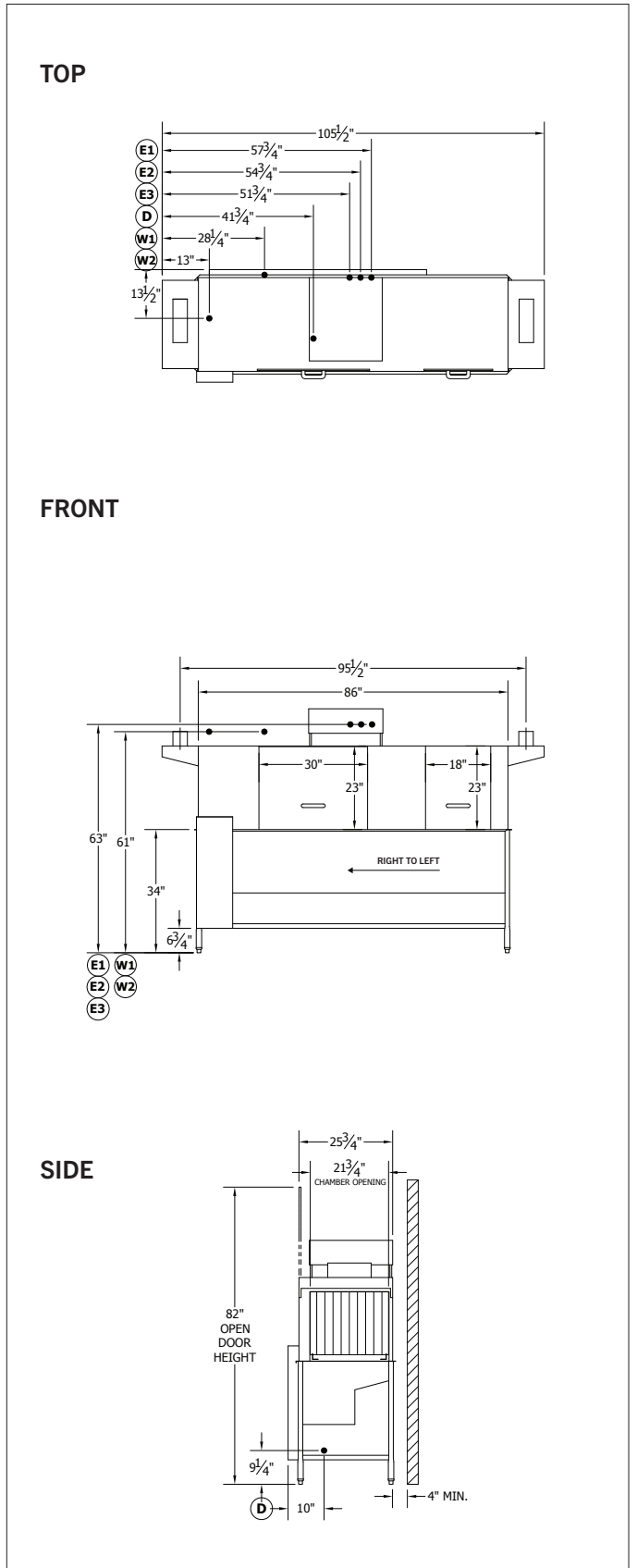

TECHNICAL INFORMATION (ELECTRIC BOOSTER)

LEFT TO RIGHT

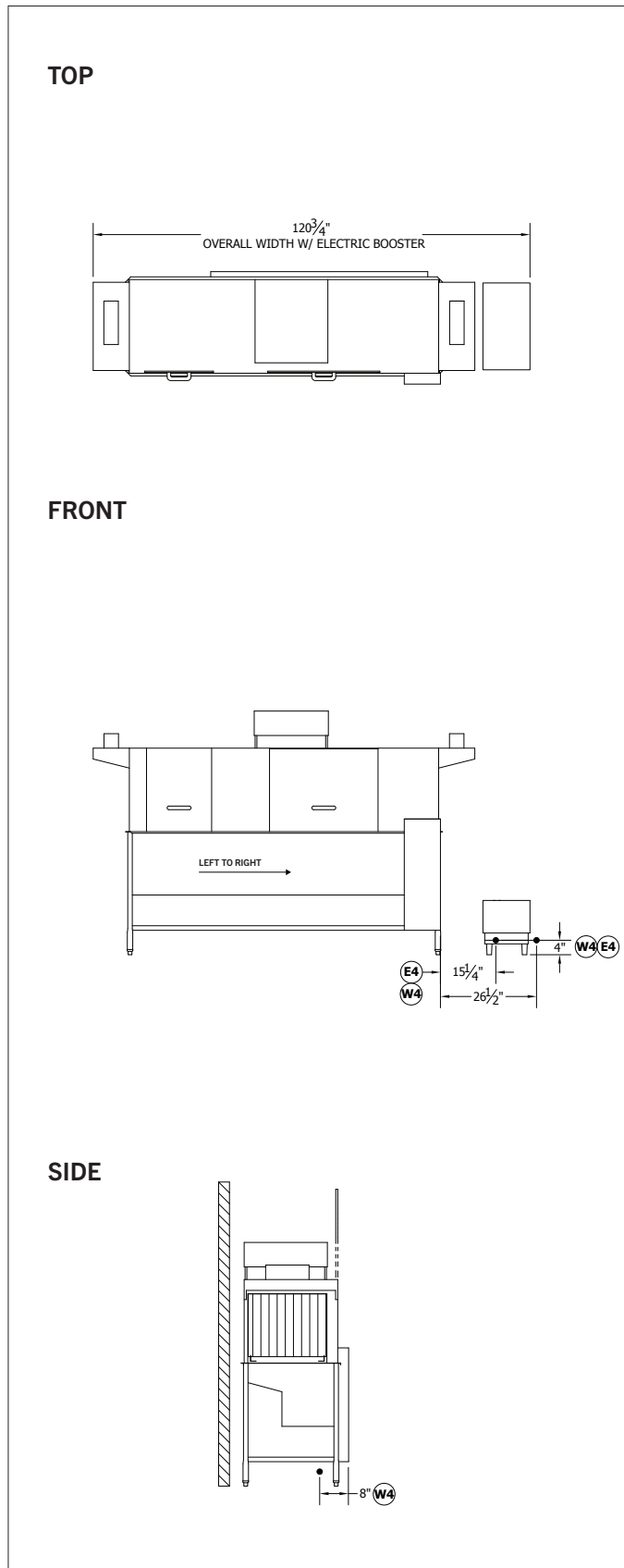

RIGHT TO LEFT

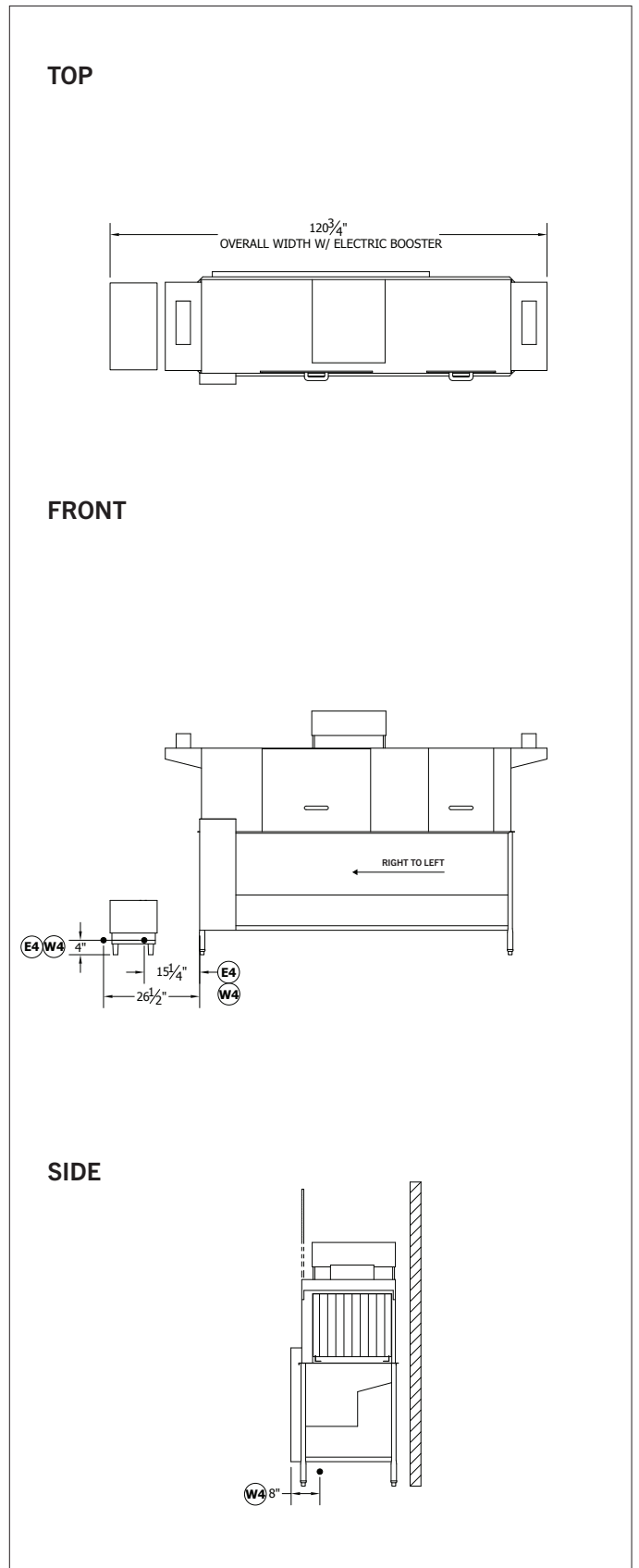

TECHNICAL INFORMATION (STEAM)

LEFT TO RIGHT

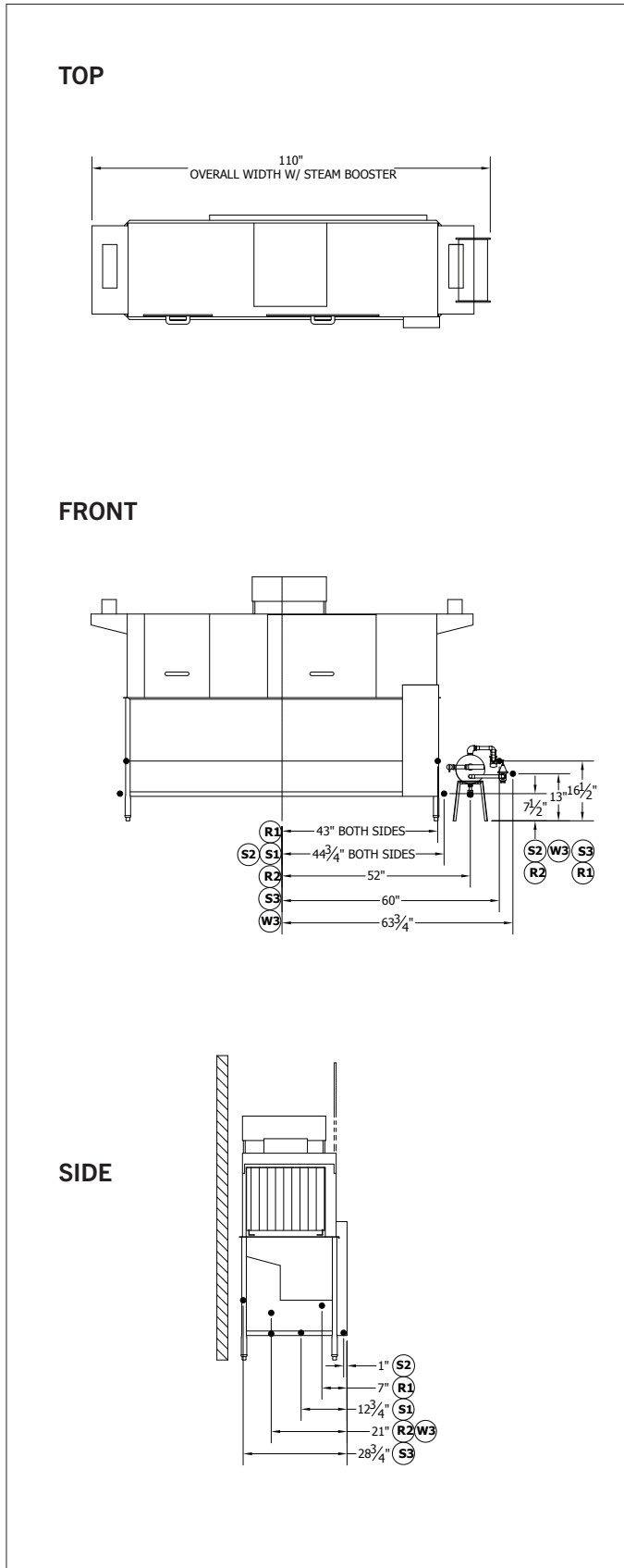

RIGHT TO LEFT

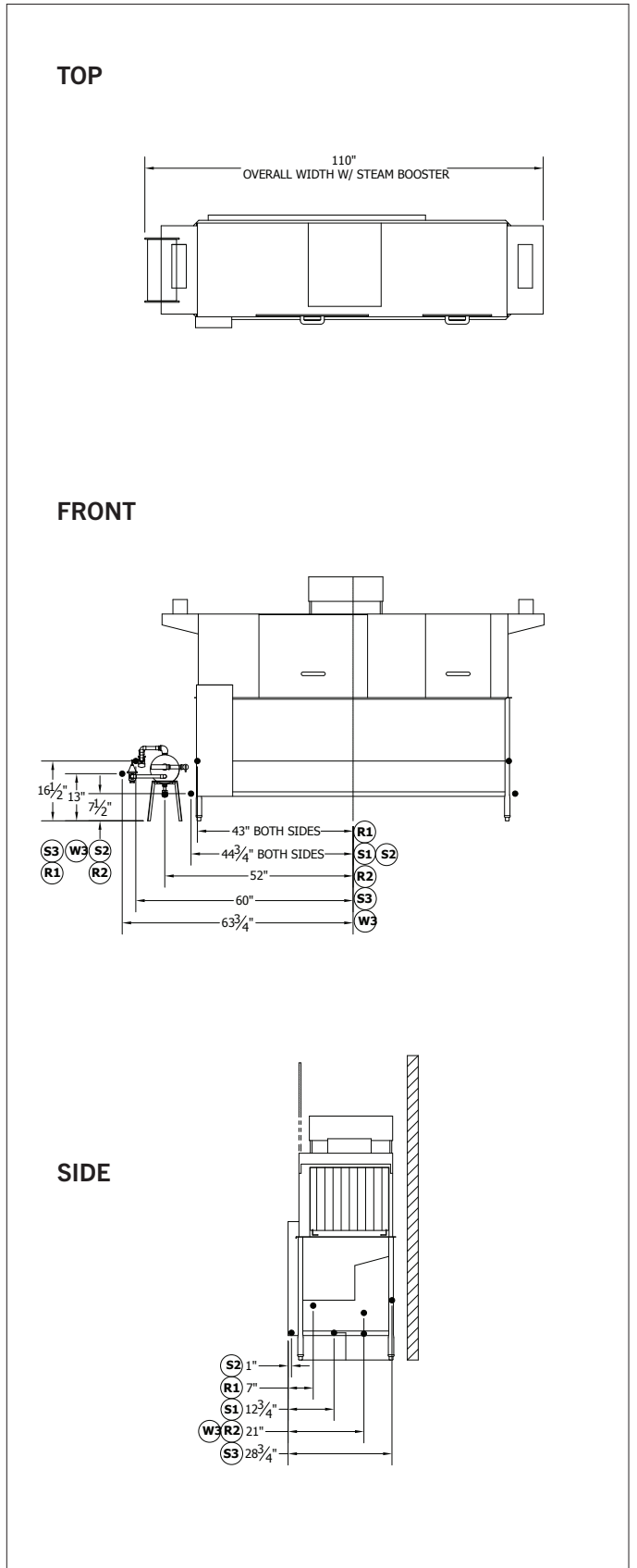

SPECIFICATIONS

Capacity	Racks Per Hour (20"x 20")	277
	Dishes Per Hour	6,925
	Meals Per Hour	300-600
Heating & Venting	Wash Tank Heat	7.5 kW
	Rinse Tank Heat	15 kW
	Booster Heat (40°F Rise)	15 kW
	Booster Heat (70°F Rise)	27 kW
	Venting (Load End)	350 CFM
	Venting (Unload End)	350 CFM
Water	Water Inlet Temperature (min.)	110°F
	Water Consumption (20 PSI)	.52 gal/rack
	Pre-Wash Tank Capacity	9 gal
	Wash Tank Capacity	12 gal
	Rinse Tank Capacity	13 gal
	Peak Drain Flow	14 gal/min
Steam	Steam Tank Consumption (20 PSI)	81 lbs/hr
	Steam Consumption (20 PSI, 40°F Rise)	51 lbs/hr
	Steam Consumption (20 PSI, 70°F Rise)	90 lbs/hr
Other	Drive Motor	1/15 HP
	Wash Motor	1.0 HP
	Rinse Motor	1.0 HP
	Shipping Weight	1,200 lbs

LEGEND

Type	Label	Description	Note
Water	W1	HOT WATER TO AUTO FILL	3/4 FIPS
	W2	HOT WATER TO FINAL RINSE	1/2 FIPS
	W3	HOT WATER TO STEAM BOOSTER	1/2 FIPS
	W4	HOT WATER TO ELECTRIC BOOSTER	1/2 FIPS
Electrical	D	DRAIN CONNECTION	2 FIPS
	E1	ELECTRICAL SERVICE MOTORS	2.25 HP
	E2	ELECTRICAL SERVICE WASH HEAT	7.5 kW
	E3	ELECTRICAL SERVICE RINSE HEAT	15 kW
Steam	E4	ELECTRICAL SERVICE BOOSTER	15 or 27 kW
	S1	STEAM TO WASH TANK	1/2 FIPS
	S2	STEAM TO RINSE TANK	3/4 FIPS
Other	S3	STEAM TO BOOSTER	1/2 - 1 FIPS
	R1	CONDENSATE RETURN TANK COILS	1/2 FIPS
	R2	CONDENSATE RETURN BOOSTER	1/2 FIPS

Contact Insinger Sales at 800-344-4802 for an installation drawing specific to your application.
 Note: Due to product improvement we reserve the right to change information and specifications without notice.

ELECTRICAL

	Service Options	Speeder 86 (Electric Tank Heat)	15 kW Booster	27 kW Booster	Speeder 86 (Steam Tank Heat)
Electrical Options	208/60/3	73.1 A	41.7 A	75 A	10.7 A
	240/60/1	112.8 A	62.5 A	112.5 A	9.7 A
	240/60/3	63.9 A	36.1 A	65 A	9.8 A
	380/50/3	40.0 A	Contact Factory		5.9 A
	480/60/3	31.9 A	18.1 A	32.5 A	4.9 A

TABLE CONFIGURATION

