



Project _____

Item _____ Quantity _____

Approved by _____ Date _____

AIA/SIS # _____



TRAC 321 RPW

Double Tank Tray Washer with Pre-Wash



528

Trays Per Hour



CrossFire™ Wash System



Made in the USA

SPECIFIER STATEMENT

Specified unit will be a TRAC 321 RPW double tank tray washer with recirculating pre-wash and wash and a fresh water final rinse system. Features include color-coded curtains, CrossFire wash system, top-mounted NEMA 12 control panel, automatic tank fill, and capillary thermometers for wash and rinse. Includes a 1-year parts and labor warranty.

STANDARD FEATURES

- Washes 528 trays (15") per hour
- ColorCorrect curtains
- CrossFire™ wash system cleans tray surfaces from top, bottom and sides
- Recirculating pre-wash tank
- Top-mounted NEMA 12 control panel
- TRAC series is the only NSF® approved tray washing solution
- Automatic tank fill
- Capillary thermometers for wash and rinse
- Detergent connection provision
- Door safety switch
- End caps/pipe plugs secured to prevent loss
- In-line thermometer for final rinse
- Inspection door
- Left or right hand configuration
- Low water protection
- Manifold clean-out brush
- Override switch for de-liming
- Simplified scrap screen design
- Single point electrical connection: motor, controls and tank heat (Booster requires a separate connection)
- Stainless steel front enclosure panel
- Standard frame drip proof motors
- Tray unload table
- Vacuum breaker on all incoming water lines
- Vents with adjustable damper controls

OPTIONS & ACCESSORIES

- Chemical sanitizer injector package for low temperature operations (dispenser by others)
- Electric booster
- Insulated hood and door
- Pressure regulating valve and line strainer
- Security package
- Stainless steel steam coil tank heat
- Steam booster
- Tray Dryer
- Tray Stacker

TECHNICAL INFORMATION

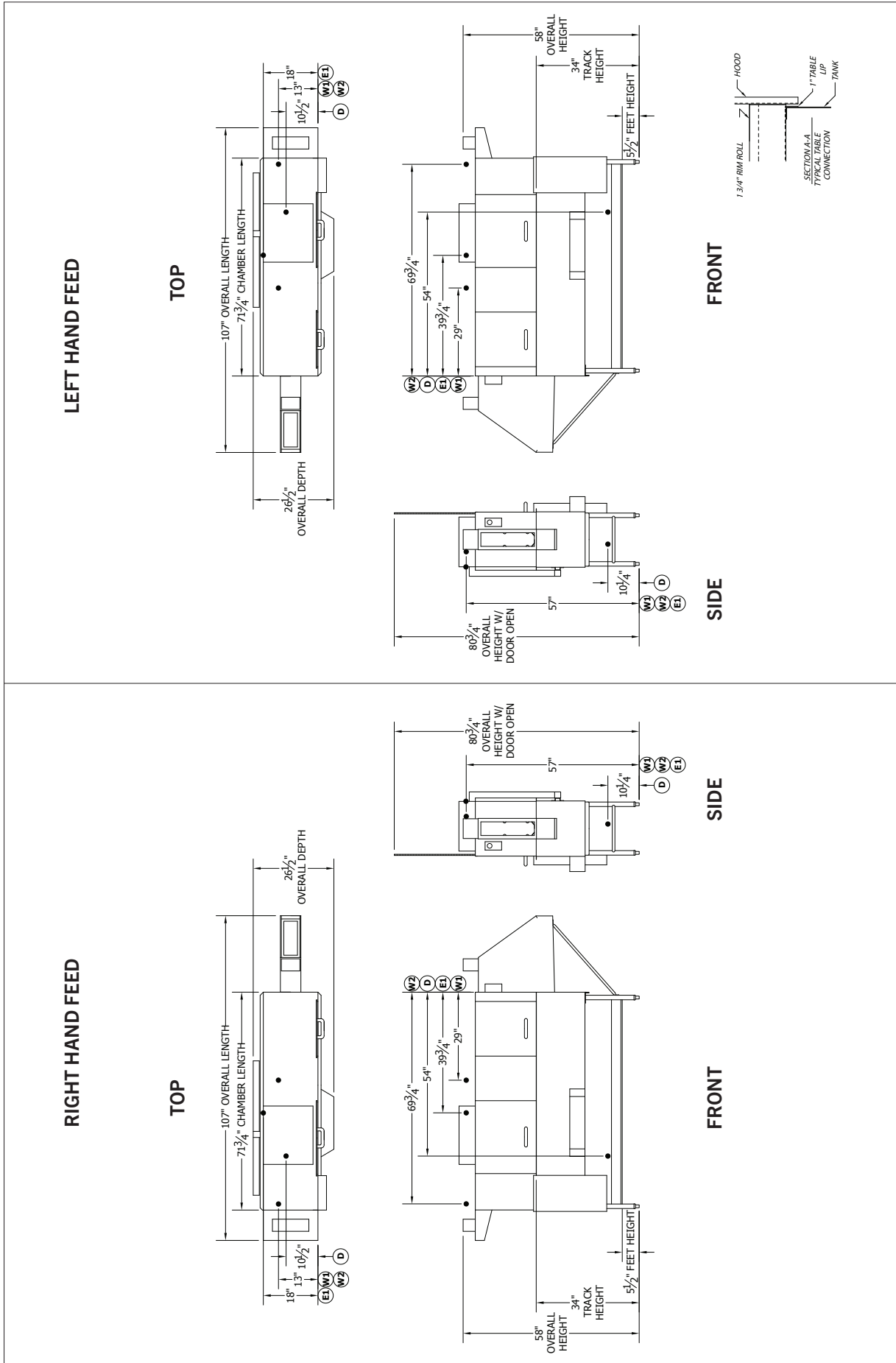

TECHNICAL INFORMATION

RIGHT HAND FEED WITH TABLE

TOP

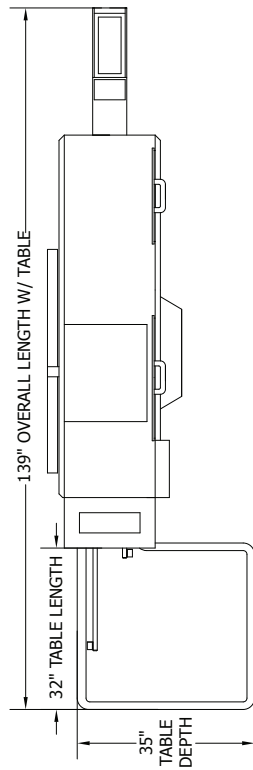

FRONT

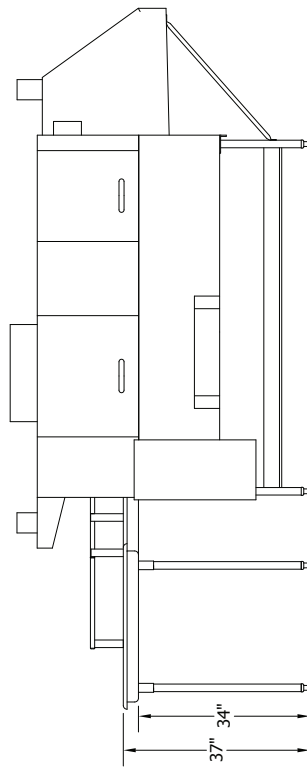

LEFT HAND FEED WITH TABLE

TOP

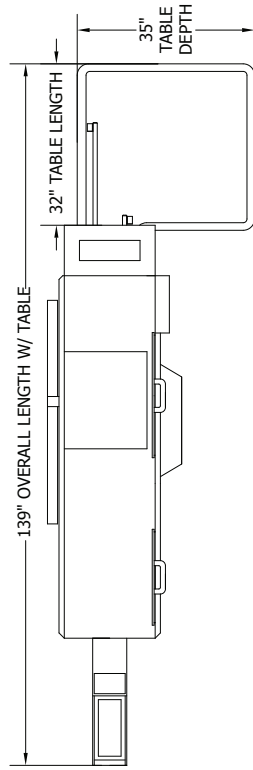

FRONT

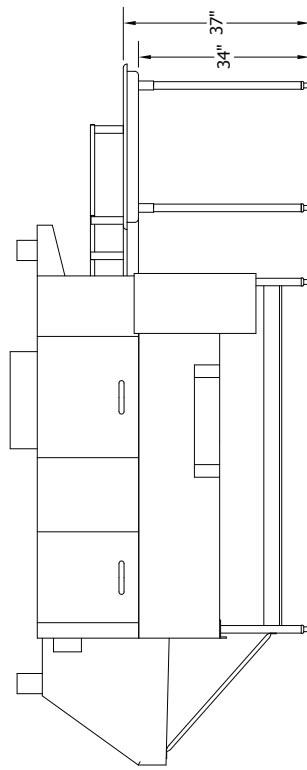

TECHNICAL INFORMATION

RIGHT HAND FEED WITH TABLE AND STEAM BOOSTER

TOP

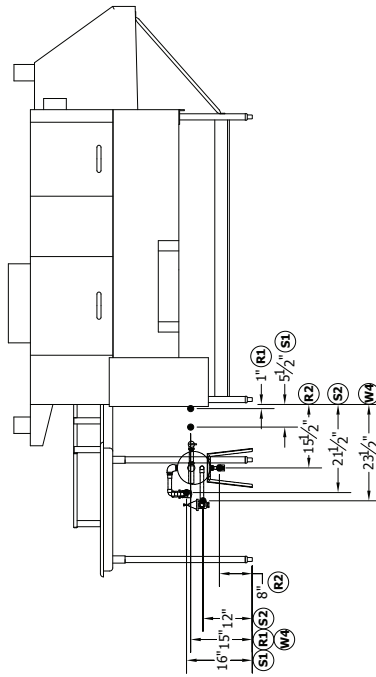
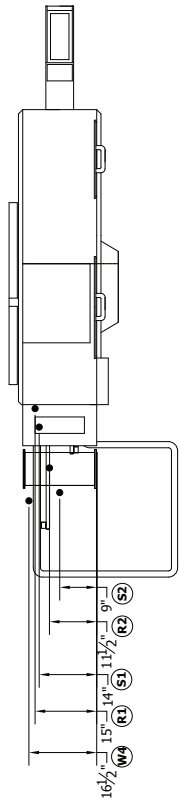

FRONT

LEFT HAND FEED WITH TABLE AND STEAM BOOSTER

TOP

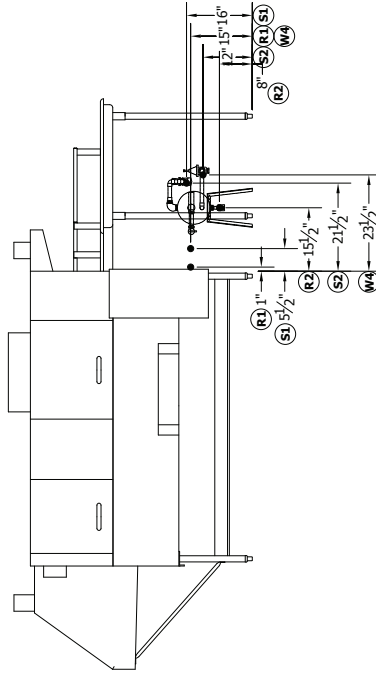
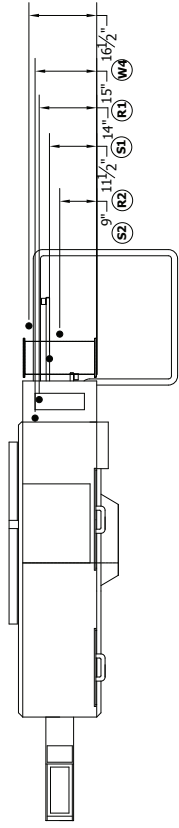

FRONT

TECHNICAL INFORMATION

RIGHT HAND FEED WITH TABLE AND ELECTRIC BOOSTER

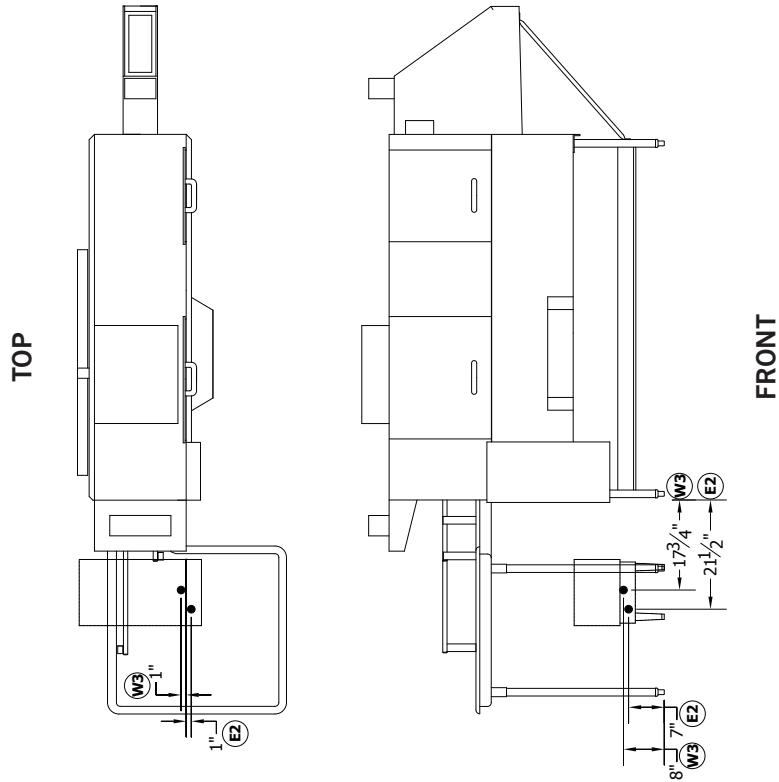

LEFT HAND FEED WITH TABLE AND ELECTRIC BOOSTER

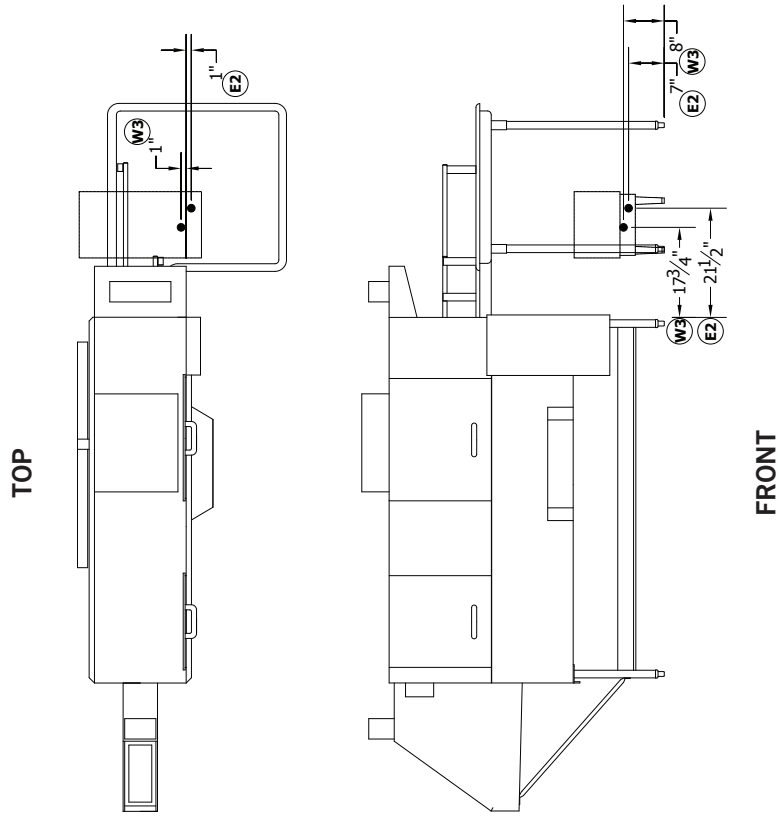

SPECIFICATIONS

Capacity	Trays Per Hour (15" tray)	528
Heating & Venting	Wash Tank Heat	15 kW
	Booster Heat (40°F Rise)	27 kW
	Booster Heat (70°F Rise)	45 kW
	Venting (Load End)	100 CFM
	Venting (Unload End)	300 CFM
Water	Water Inlet Temperature	110°F
	Water Consumption (20 PSI)	248 gal/hr
	Pre-Wash Tank Capacity	10.3 gal
	Wash Tank Capacity	24.1 gal
	Peak Drain Flow	9 gal/min
Steam	Steam Tank Consumption (20 PSI)	54 lbs/hr
Other	Pre-Wash Motor	0.5 HP
	Drive Motor	1/15 HP
	Wash Motor	2 HP
	Shipping Weight	800

ELECTRICAL

	Service Options	TRAC 321 RPW (Electric)	27 kW Booster	45 kW Booster
Electric Tank Heat	208/60/3	50.1 A	75 A	125 A
	240/60/3	43.9 A	65 A	108.3 A
	380/50/3	27.5 A	Contact Factory	
	480/60/3	21.9 A	32.5 A	54.2 A
	Service Options	TRAC 321 RPW (Steam)		
Steam Tank Heat	208/60/3	8.5 A		
	240/60/3	7.8 A		
	380/50/3	4.7 A		
	480/60/3	3.9 A		

LEGEND

Type	Label	Description	Note
Water	W1	HOT WATER TO AUTO FILL - 110F	1/2 FNPT
	W2	HOT WATER TO FINAL RINSE - 180F	1/2 FNPT
	W3	HOT WATER TO STEAM BOOSTER - 110/140F	1/2 FNPT
	W4	HOT WATER TO ELECTRIC BOOSTER - 110/140F	1/2 FNPT
	D	DRAIN CONNECTION	1.5 FNPT
Electrical	E1	ELECTRIC SERVICE - WASH HEATERS & MOTORS	2.6 HP + 15 kW
	E2	ELECTRIC SERVICE - BOOSTER	27 or 45 kW
Steam	S1	STEAM TO TANKS	1/2 FNPT
	S2	STEAM TO BOOSTER	1/2 OR 3/4 FNPT
Other	R1	CONDENSATE RETURN - COILS	3/8 FNPT
	R2	CONDENSATE RETURN - BOOSTER	1/2 FNPT



Tray entering a TRAC 321 RPW.

Contact Insinger Sales at 800-344-4802 for an installation drawing specific to your application.
 Note: Due to product improvement we reserve the right to change information and specifications without notice.